

Innenausbau

Gesamtübersicht

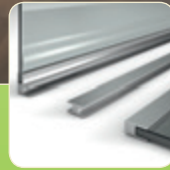

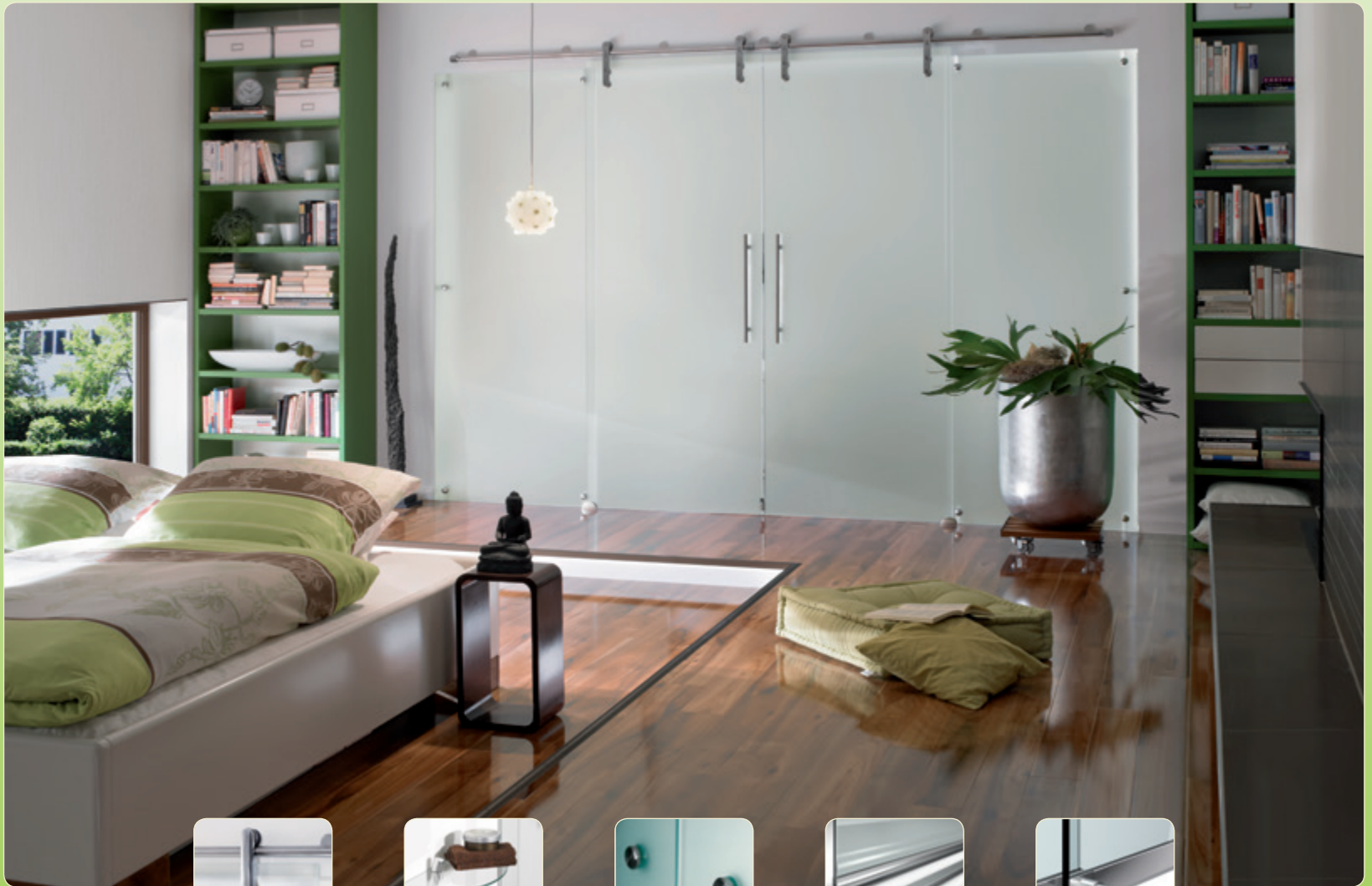

- **Glastüranlagen** 06
 - Vorstellung der Produkte 10
 - Einzelteile 18
 - Typenübersicht 36
 - Sets PS100/PS200/PS300 40
 - Planungshilfe für Wand- und Glasbefestigung 44
 - Berechnungsbeispiel 52
- **Profile und Trennwände** 60
 - Profile 64
 - Trennwandstützen 78
 - Winkelverbinder 80
 - Toiletten-/Umkleidekabinen 84
- **Glasschiebetürbeschläge** 104
 - Schiebetürbeschlag Modell 2100 108
 - Schiebetürbeschlag Modell 2200 118
 - Zubehör 124
- **Punkthalter** 128
 - Punkthalter erhaben 132
 - Punkthalter flächenbündig für Lichtdecken 150
 - Punkthalter flächenbündig 154
 - Zubehör 164
 - Befestigungswinkel 166
- **Glasplattenträger** 170
 - Glasplattenträger Zink 175
 - Glasplattenträger Edelstahl 187
 - Glasplattenträger Zink „Design-Kollektion“ 195
 - Verbindersystem 200
 - Klemmen 205
- **Allgemein** 04
 - Vorstellung 04
 - Pflegehinweise 208
 - AGB 211

Glastüranlagen

Profile und
Trennwände

Glasschiebetür-
beschläge

Punkthalter

Glasplattenträger

Allgemein



Glastüranlagen

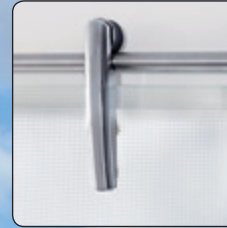
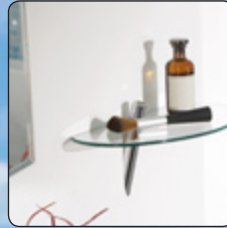

Profile und Winkelverbinder

Glasschiebetür-
beschläge

Punkthalter

Glasplattenträger

Allgemein



Unsere Philosophie: Qualität made in Germany

Pauli + Sohn agiert im Rahmen einer ganzheitlichen Firmenphilosophie, die auf Perfektion, Qualität, Tradition und Ethik basiert. Unser Produktionsstandort ist und bleibt Deutschland. Hier haben wir uneingeschränkten Einfluss auf die Verwendung hochwertiger Materialien und deren sorgfältige Verarbeitung.

Unser lückenloses Qualitätsmanagement ist seit über 30 Jahren der Garant für die hohe Wertigkeit unserer rund 5.000 Hightech-Produkte. Hochwertiges Design, exzellente Funktionalität und die Vielfalt der Produkte machen Ihren Wohnbereich zu einer Welt der Inspiration.



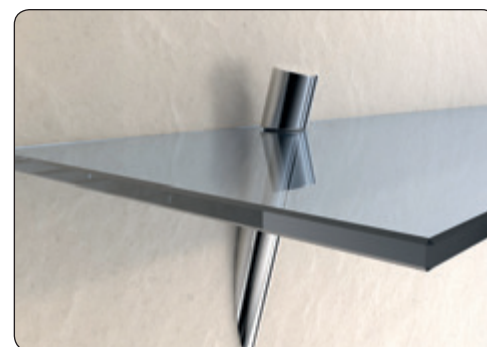
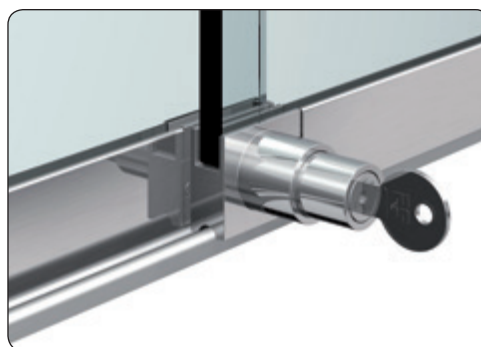
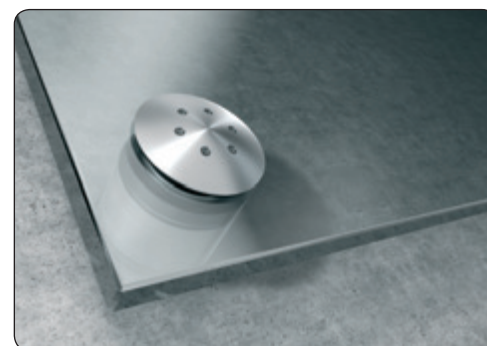
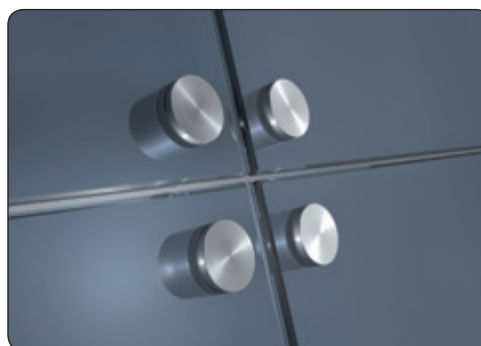
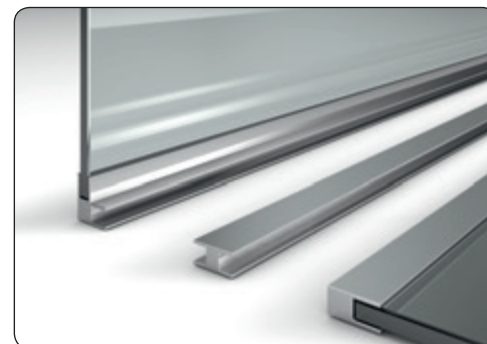

Glastüranlagen

Profile und Winkelverbinder

Glasschiebetürbeschläge

Punkthalter

Glasplattenträger

Allgemein

Großer Auftritt für eine umfangreiche Kollektion

Pauli + Sohn bietet für unterschiedliche Raumsituationen eine große Auswahl an Glshalterungen. Die verschiedenen Systeme unterstützen den transparenten Charakter von Glas und basieren auf dem einfachen und gleichzeitig anspruchsvollen Prinzip von Form und Funktion.

Sie bringen den Wohnraum oder Bäder in Schwung, dienen als Regal oder Ablage, dekorieren Wände oder trennen transparent Ihre Wohnbereiche.





■ Glastüranlagen



■ Inhalt



- Vorstellung der Produkte 10
- Einzelteile 18
- Typenübersicht 36
- Sets PS100/PS200/PS300 40
- Planungshilfe für Wand- und Glasbefestigung 44
- Berechnungsbeispiel 52

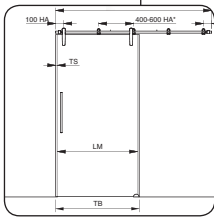
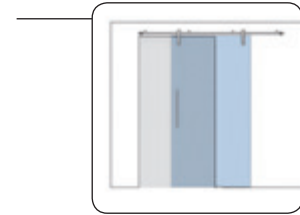





Glastüranlagen

■ Kurzbezeichnungen für Material- und Ausführungsarten

ZN = Zink

 ZN5 = glanzverchromt

 ZN22 = Edelstahloptik

 ZN22-K = Edelstahloptik mit Klarlack

 ZNPVD22 = Edelstahloptik für Duschbeschlag

VA = Edelstahl

 VA = Oberfläche geschichtet

 VA1 = poliert

 VA2 = matt gebürstet

Inlays

 VA35 = helles Ahorn

 VA36 = dunkle Wenge



PS 100





Vorteile

- Tragkraft bis 120kg/Paar
- Laufwagen aus Edelstahl
- auch im Nassbereich einsetzbar
- geeignet für Glas, Holz, Metall und Kunststoff



- verschiedene Varianten zur Aufhängung



- Gesamtes Zubehör passend zur Laufschiene Ø 25 mm, für alle Laufwagen geeignet.



PS 200





Vorteile

- Verschraubung im Laufwagen, keine sichtbare Verschraubung
- Oberfläche des Laufwagens in glanzverchromt und Edelstahloptik
- auch flächenbündig erhältlich, Verstellbarkeit ± 2 mm
- Tragkraft 135kg/Paar
- je nach Oberfläche auch im Nassbereich einsetzbar



- verschiedene Varianten zur Aufhängung



- Gesamtes Zubehör passend zur Laufschiene $\varnothing 25$ mm, für alle Laufwagen geeignet.

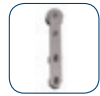

PS 300





Vorteile

- individuelle Abdeckung durch Inlays möglich
- keine sichtbare Verschraubung
- Tragkraft bis 120kg/Paar
- Laufwagen aus Edelstahl



- verschiedene Varianten zur Aufhängung



- Gesamtes Zubehör passend zur Laufschiene Ø 25 mm, für alle Laufwagen geeignet.



■ Laufschienenklemme



Vorteile

- keine Bohrung in Laufschiene erforderlich, wird nur geklemmt
- freie Positionierung der Klemmen möglich
- schnelle Lieferung durch einfache Konfektionierung
- Laufschienenklemme bietet eine Aushebesicherung
- für Laufschiene (32012VA) und Laufrohr (32005VA2) verwendbar



■ Laufschienenklemme



Glastüranlagen



Abstand und Anzahl der Laufschienenklemme ist abhängig von der Türblattbreite. Mindestens zwei Klemmen sind stets oberhalb des Türblattes einzuplanen, um so eine Aushebesicherung zu gewährleisten.





■ Laufwagen

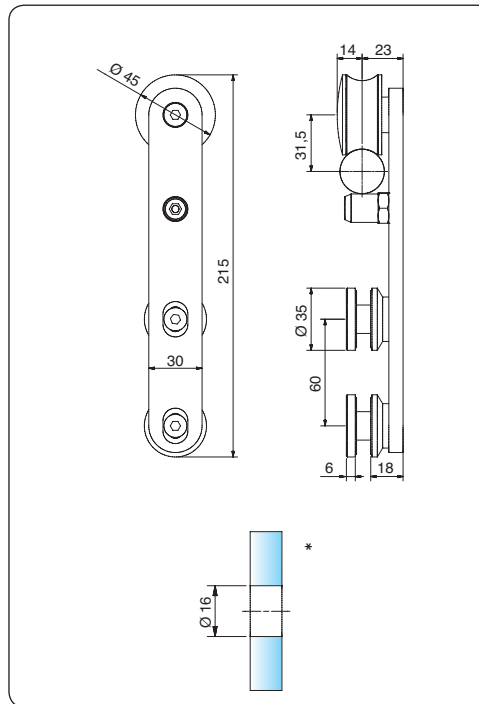

Art. Nr.: 32070

Rollwagen erhaben für Laufschiene 32014 und 32016, Tragkraft 120kg/Paar

Plattenstärke:  8-12 mm

Material/Oberfläche VA = Edelstahl



VA2

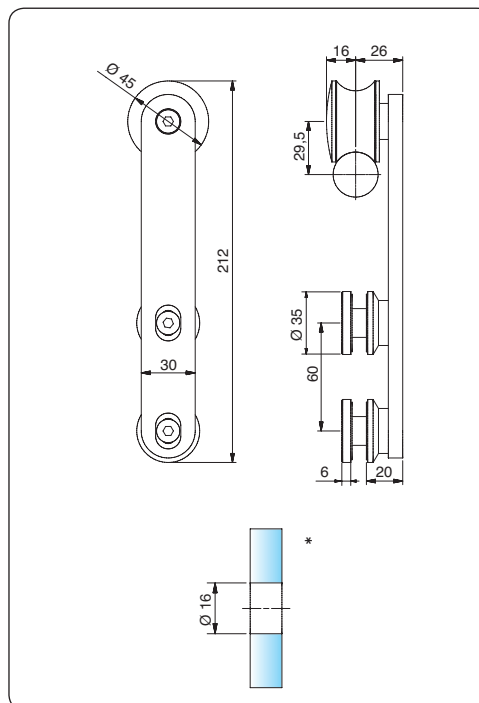

Art. Nr.: 32072

Rollwagen erhaben für Laufschiene 32005 und 32012 mit Klemme, Tragkraft 120kg/Paar

Plattenstärke:  8-12 mm

Material/Oberfläche VA = Edelstahl



VA2

*die erweiterte Glasbearbeitung finden Sie ab Seite 45.

Glastüranlagen



Laufwagen

PS200

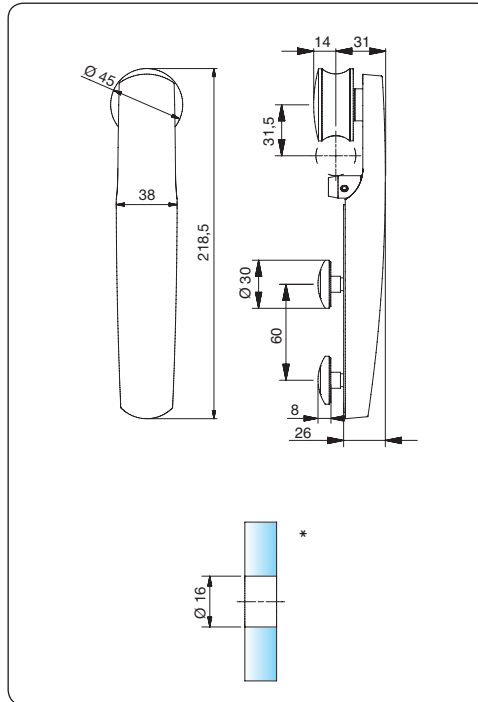

Art. Nr.: 32002

Rollwagen erhaben für Laufschiene 32014 und 32016, Tragkraft 135kg/Pair

Plattenstärke: 8–12 mm

Material/Oberfläche

ZN = Zink



ZN22



ZN5



ZN22-K



ZNPVD22

auf Anfrage

PS200

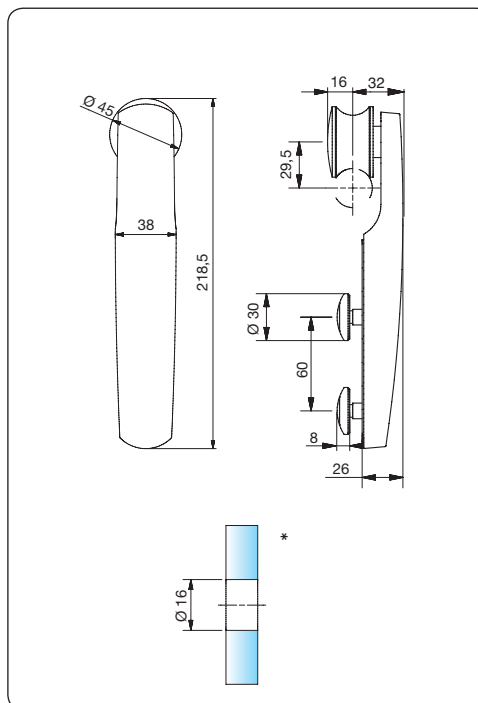

Art. Nr.: 32008

Rollwagen erhaben für Laufschiene mit Klemme 32005 und 32012, Tragkraft 135kg/Pair

Plattenstärke: 8–12 mm

Material/Oberfläche

ZN = Zink



ZN22



ZN5



ZN22-K



ZNPVD22

auf Anfrage

*die erweiterte Glasbearbeitung finden Sie ab Seite 45.



■ Laufwagen

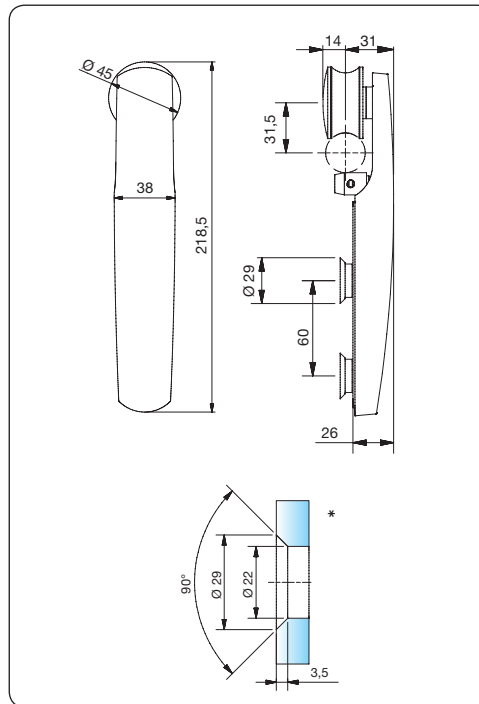

Art. Nr.: 32000

Rollwagen flächenbündig für Laufschiene 32014 und 32016, Tragkraft 135kg/Pair

Plattenstärke:  8–12 mm

Material/Oberfläche ZN = Zink



ZN22



ZN5



ZN22-K



ZNPVD22

auf Anfrage

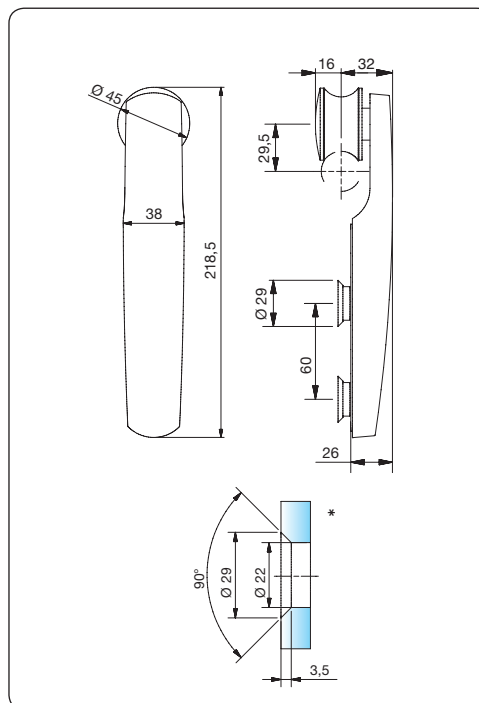

Art. Nr.: 32006

Rollwagen flächenbündig für Laufschiene mit Klemme, 32005 und 32012, Tragkraft 135kg/Pair

Plattenstärke:  8–12 mm

Material/Oberfläche ZN = Zink



ZN22



ZN5



ZN22-K



ZNPVD22

auf Anfrage

*die erweiterte Glasbearbeitung finden Sie ab Seite 45.



■ Laufwagen

PS300

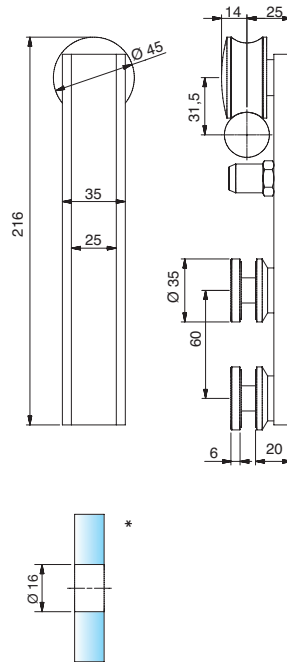

Art. Nr.: 32080

Rollwagen erhaben für Laufschiene 32014 und 32016, Tragkraft 120kg/Pair

Plattenstärke: 8–12 mm

Material/Oberfläche VA = Edelstahl

mit Inlay



VA35
helles Ahorn



VA36
dunkle Wenge

PS300

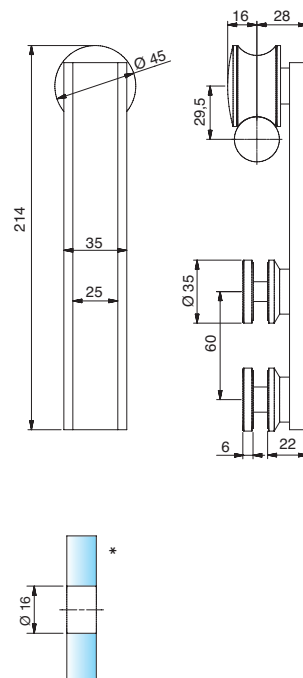

Art. Nr.: 32082

Rollwagen erhaben für Laufschiene mit Klemme 32005 und 32012, Tragkraft 120kg/Pair

Plattenstärke: 8–12 mm

Material/Oberfläche VA = Edelstahl

mit Inlay



VA35
helles Ahorn



VA36
dunkle Wenge

*die erweiterte Glasbearbeitung finden Sie ab Seite 45.



■ Laufwagen

Inlay Dekore



helles
Ahorn
VA35



dunkle
Wenge
VA35





Zubehör

Sie finden in unserem Zubehörprogramm unterschiedliche Glas-Glas- bzw. Glas-Wand-Befestigungen, „einfache“ Anschlags-Puffer, Griff-Modelle und vieles andere. Alle Zubehörteile sind passend zu PS100, PS200 und PS300.





Zubehör

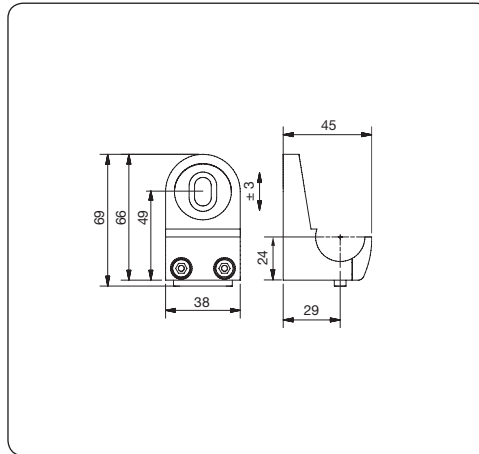

Art. Nr.: 32004

Laufschielenklemme für Laufschiene 32005 und 32012, Bohren der Laufschiene nicht notwendig inkl. Befestigungsschraube

Material/Oberfläche

ZN = Zink



ZN22



ZN5



ZN22-K



ZNPVD22

auf Anfrage

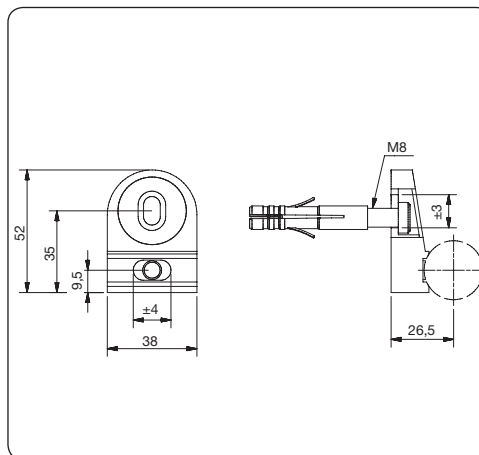

Art. Nr.: 32010

Wandbefestigung für Laufschiene 32014, verdeckte Montage, Abstand 26,5 mm, horizontal und vertikal verstellbar inkl. Befestigungsschraube

Material/Oberfläche

ZN = Zink



ZN22



ZN5



ZN22-K



ZNPVD22

auf Anfrage

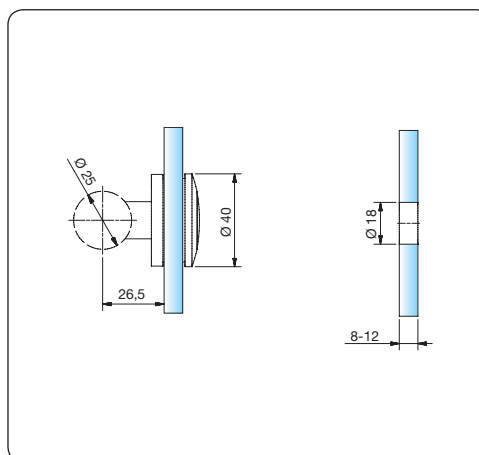
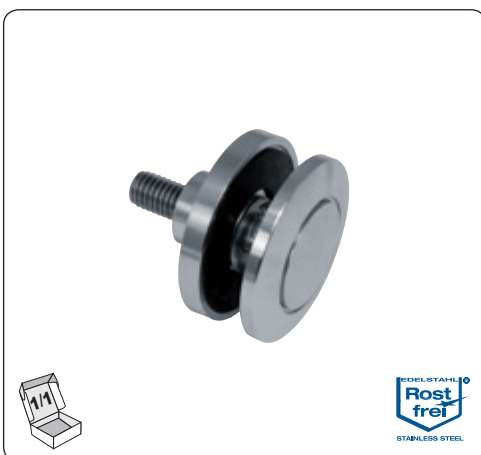

Art. Nr.: 32034

Glasanschluss für Laufschiene 32016

Plattenstärke:



8-12 mm

Material/Oberfläche

VA = Edelstahl



VA



VA1 auf Anfrage





Zubehör

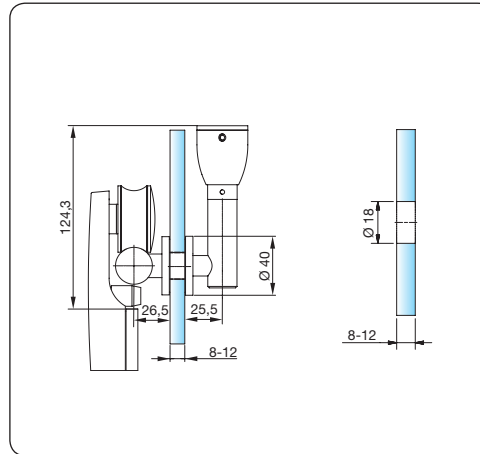

Art. Nr.: 32035

Glasanschluss für Deckenabhängung,
Laufschiene 32016

Plattenstärke: 8-12 mm

Material/Oberfläche VA = Edelstahl



VA



VA1 auf Anfrage

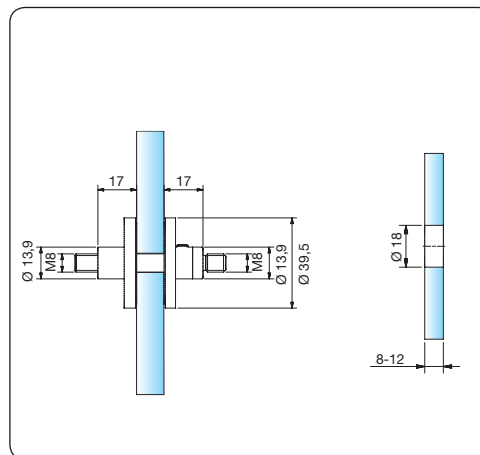

Art. Nr.: 32036

Glasanschluss für zwei Laufschiene 32016

Plattenstärke: 8-12 mm

Material/Oberfläche VA = Edelstahl



VA



VA1 auf Anfrage

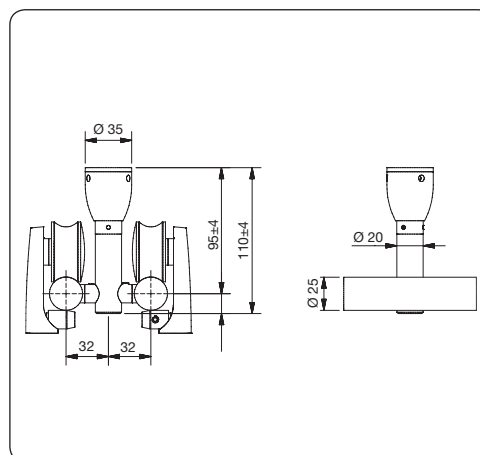

Art. Nr.: 32056

Deckenhalterung mit Doppelführung
2-dimensional verstellbar (vertikal, horizontal),
Länge = 95 mm, für Laufschiene 32016

Material/Oberfläche VA = Edelstahl



VA



VA1 auf Anfrage



Zubehör

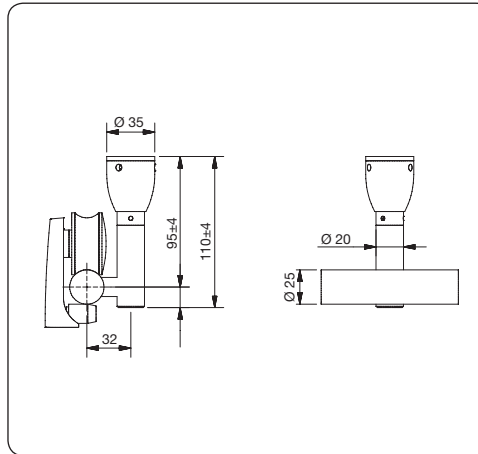

Art. Nr.: 32052

Deckenhalterung 2-dimensional
verstellbar (vertikal, horizontal), Länge = 95 mm,
für Laufschiene 32016

Material/Oberfläche

VA = Edelstahl



VA



VA1 auf Anfrage

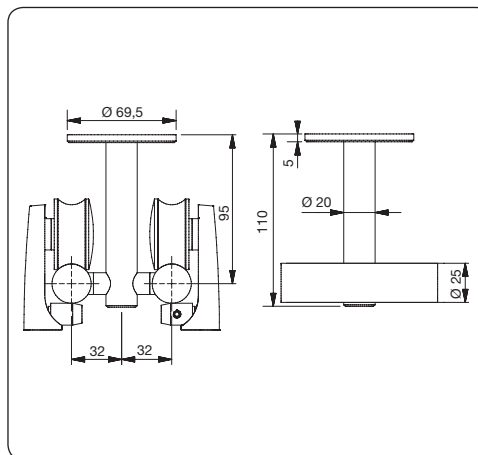

Art. Nr.: 32054

Deckenhalterung mit Doppelführung,
Länge = 95mm, für Laufschiene 32016

Material/Oberfläche

VA = Edelstahl



VA



VA1 auf Anfrage

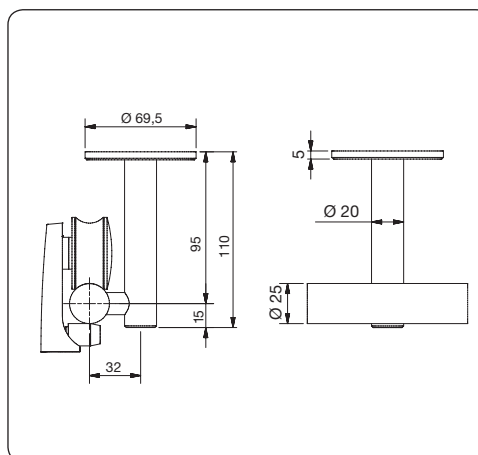

Art. Nr.: 32050

Deckenhalterung, Länge = 95 mm
für Laufschiene 32016

Material/Oberfläche

VA = Edelstahl



VA



VA1 auf Anfrage



Zubehör



Art. Nr.: 32012, 32014, 32016

Laufschiene Ø 25 mm

für Klemme 32004, ungebohrt

32012VA-2000 bis 2000 mm

32012VA-2600 2001-2600 mm

32012VA-V > 2600 mm**

für Wandhalter 32010

32014VA-2000 bis 2000 mm

32014VA-2600 2001-2600 mm

32014VA-V > 2600 mm**

für Glas und Deckenanschluss

32016VA-2000 bis 2000 mm

32016VA-2600 2001-2600 mm

32016VA-V > 2600 mm**

Material/Oberfläche VA = Edelstahl



VA2



VA1 auf Anfrage

** Ab 2601 mm wird mindestens eine Kupplung 32018 mitgeliefert.

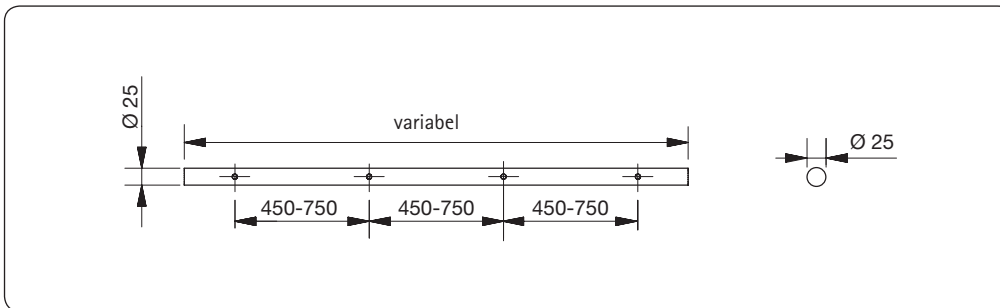

Art. Nr.: 32005

Laufrohr Ø 25 mm

für Klemme, ungebohrt, inklusive 2x Endkappen

32005VA2-2000 L = 2000 mm

32005VA2-2600 L = 2001-2600 mm

32005VA2-V L = > 2600 mm***

Material/Oberfläche VA = Edelstahl



VA2



VA1 auf Anfrage

*** Ab 2601 mm wird mindestens eine Kupplung 32065 mitgeliefert.

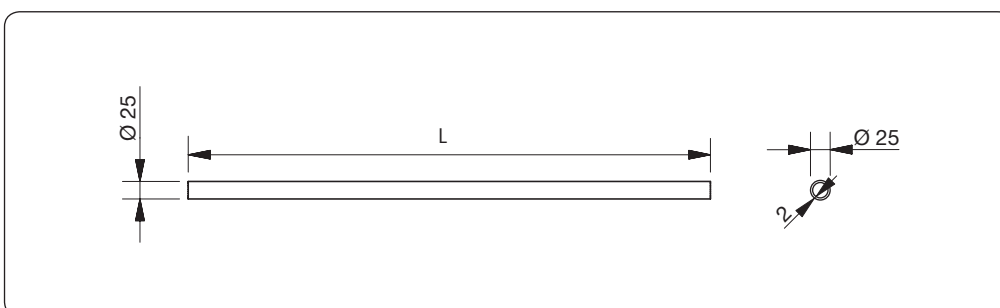



■ Zubehör

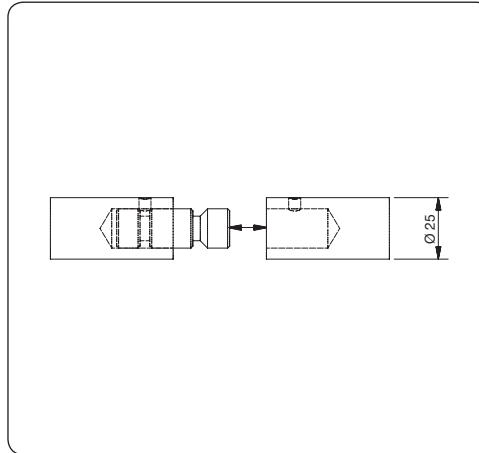
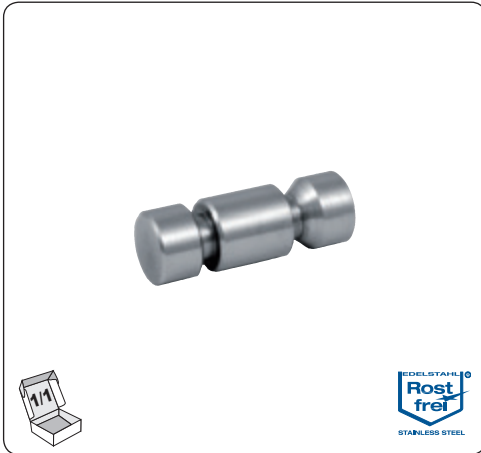

Art. Nr.: 32018

Laufschienenverlängerung (wird an den zugehörigen Enden angedreht) für Laufschiene 32012, 32014 und 32016

Material/Oberfläche

VA = Edelstahl



VA

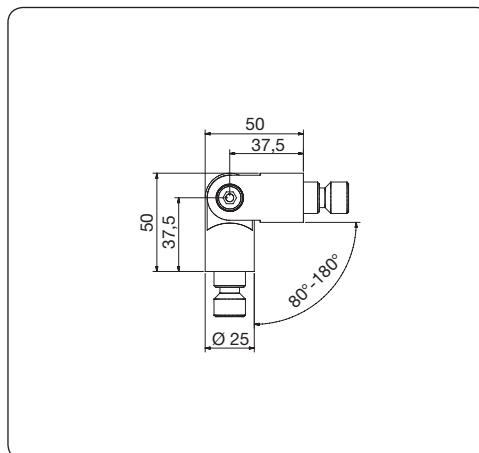

Art. Nr.: 32017

Laufschienenverlängerung, variabel 80°-180 (wird an den zugehörigen Enden angedreht) für Laufschiene 32012, 32014 und 32016

Material/Oberfläche

VA = Edelstahl



VA



VA1 auf Anfrage



Zubehör

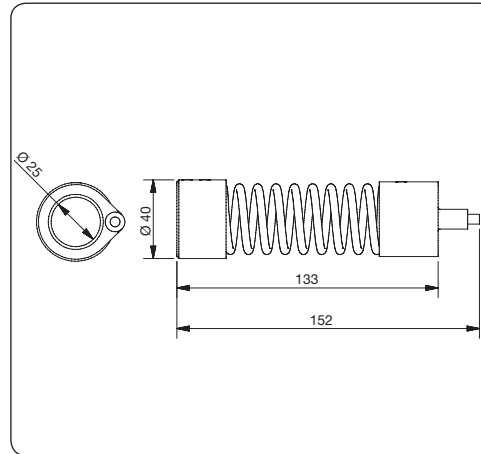
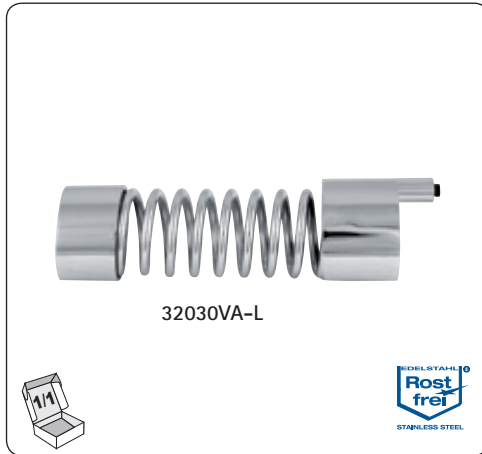

Art. Nr.: 32030-R/32030-L

Federstopper rechts oder links für Laufschiene

Material/Oberfläche VA = Edelstahl



VA2



VA1 auf Anfrage

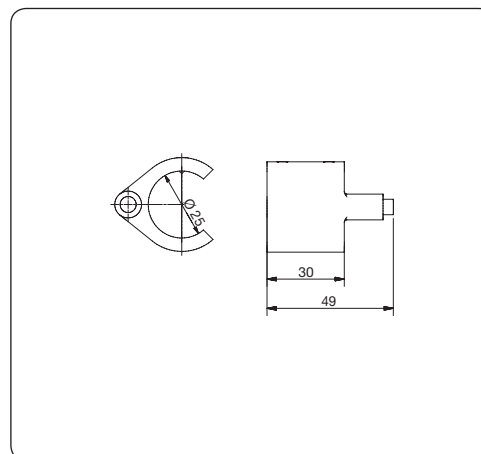
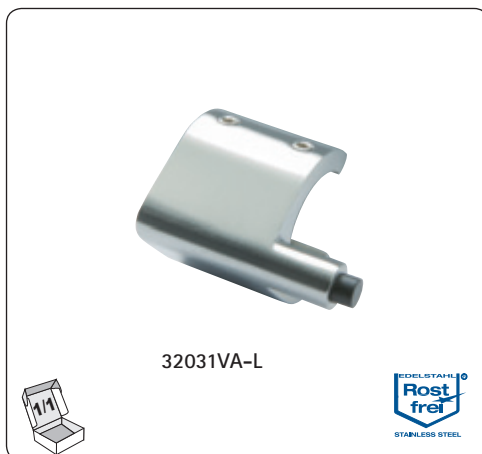

Art. Nr.: 32031-R/32031-L

Stopper rechts oder links für Laufschiene

Material/Oberfläche VA = Edelstahl



VA2



VA1 auf Anfrage

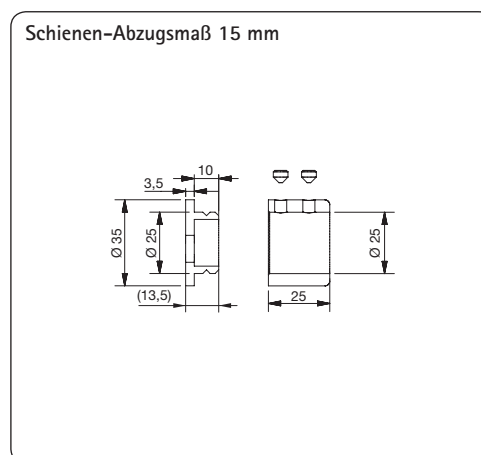

Art. Nr.: 32033

Wandlager für Nischenlösung zweiteilig mit einem Befestigungspunkt für Zylinderkopfschraube M6

Material/Oberfläche VA = Edelstahl



VA



VA1 auf Anfrage



Zubehör



Schienen-Abzugsmaß 6 mm

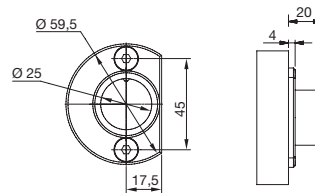

Art. Nr.: 32032

Wandlager für Nischenlösung mit 2 Befestigungspunkten für Senkkopfschrauben M6

Material/Oberfläche

VA = Edelstahl



VA



VA1 auf Anfrage

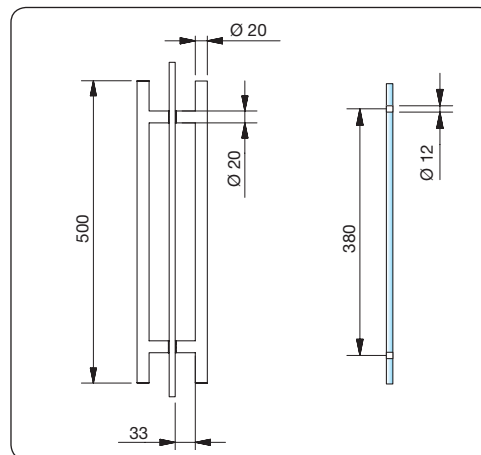
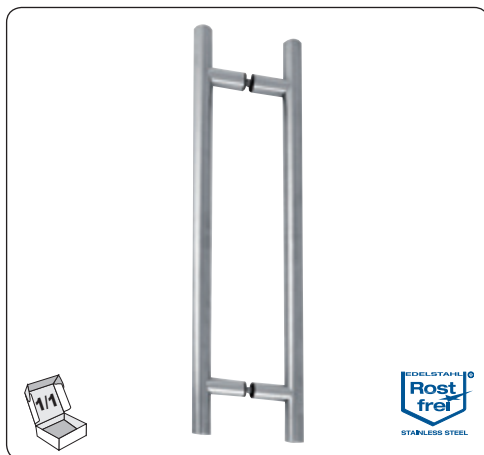

Art. Nr.: 32024, 32025

Stoßgriff beidseitig

32024VA



8-12 mm

Stoßgriff einseitig

32025VA



8-12 mm

Material/Oberfläche

VA = Edelstahl



VA2



VA1 auf Anfrage

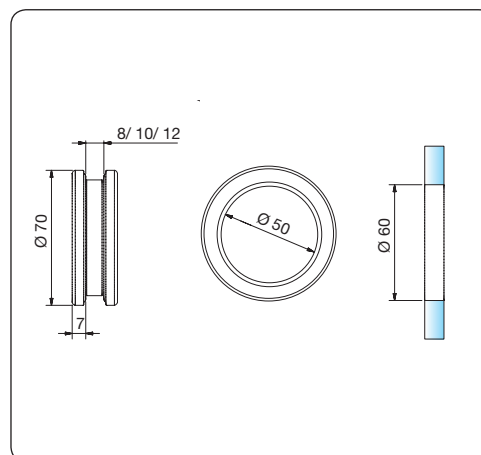

Art. Nr.: 32028

Muschelgriff zum Schrauben, 7 mm aufragend, Ø 70 mm

32028VA-8



8 mm

32028VA-10



10 mm

32028VA-12



12 mm

Material/Oberfläche

VA = Edelstahl



VA



VA1 auf Anfrage



Zubehör

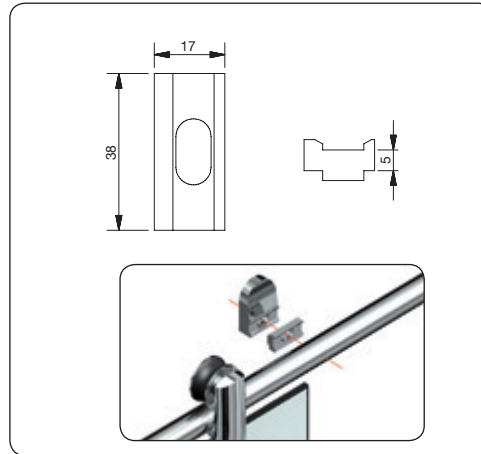
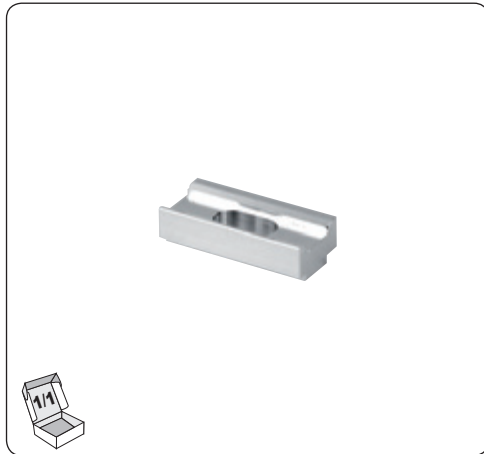

Art. Nr.: 32019

Distanzstück 5 mm für Wandbefestigung 32010

Material/Oberfläche

ZN = Zink



ZN22

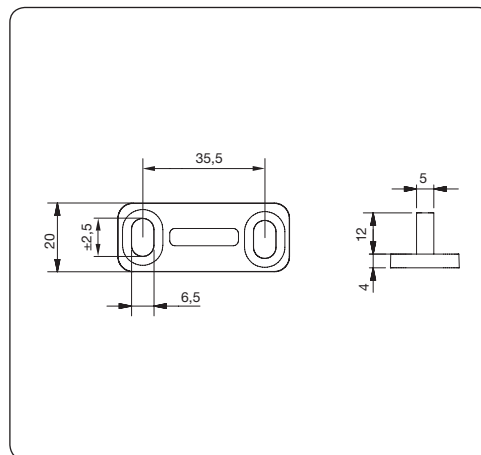
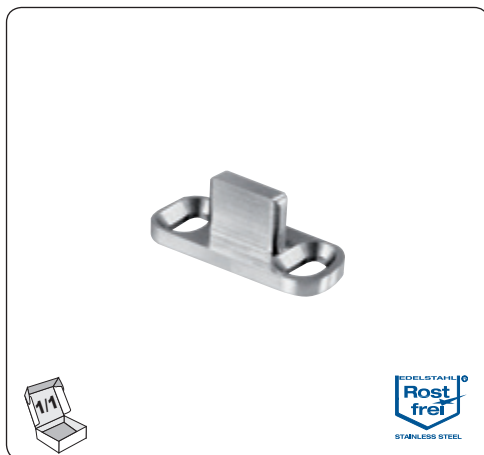

Art. Nr.: 32021

Bodenführung für Holztüren

Material/Oberfläche

VA = Edelstahl



VA

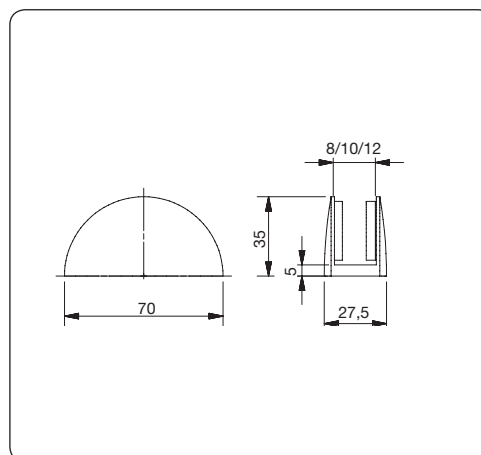

Art. Nr.: 32020, 32040

Bodenführung für Glas

32020ZN-8/-10/-12  8/-10/-12 mm

für Nassbereich

32040ZN-8/-10/-12  8/-10/-12 mm

Material/Oberfläche

ZN = Zink



ZN22



ZN5



ZN22-K



ZN22-PVD22

auf Anfrage



Zubehör

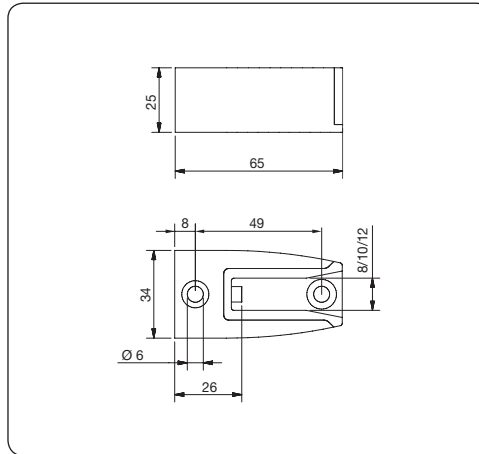

Art. Nr.: 32022

Boden-Türblattstopper

| | | |
|------------|--|-------|
| 32022ZN-8 | | 8 mm |
| 32022ZN-10 | | 10 mm |
| 32022ZN-12 | | 12 mm |

Material/Oberfläche ZN = Zink

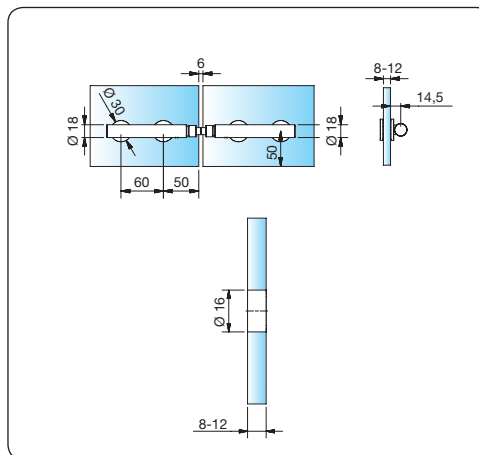
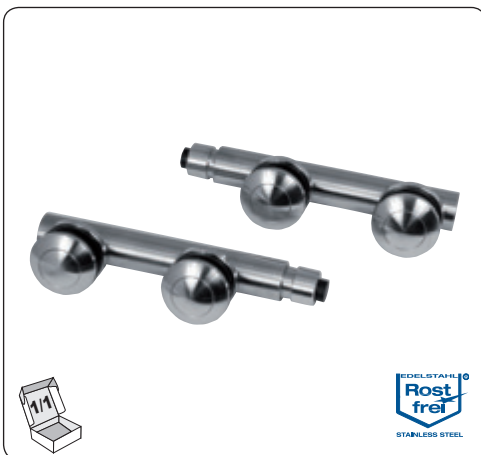

Art. Nr.: 32023

Türblattstopper mit Glasanschluß

Material/Oberfläche VA = Edelstahl

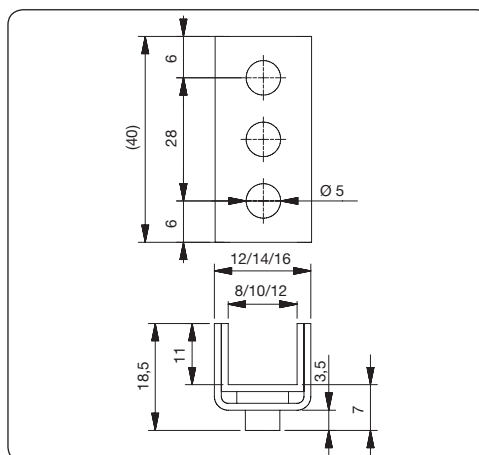

Art. Nr.: 32026

Türblattstopper

| | | |
|------------|--|-------|
| 32026VA-8 | | 8 mm |
| 32026VA-10 | | 10 mm |
| 32026VA-12 | | 12 mm |

Material/Oberfläche VA = Edelstahl





Zubehör

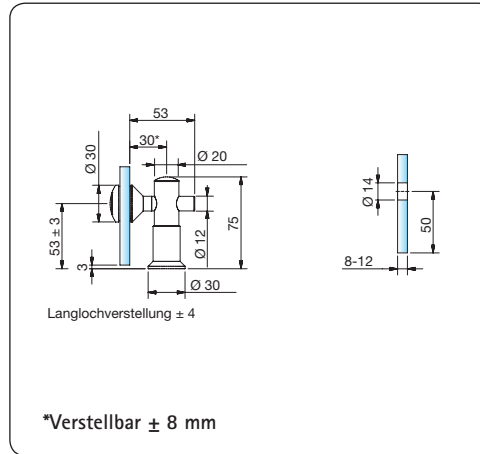
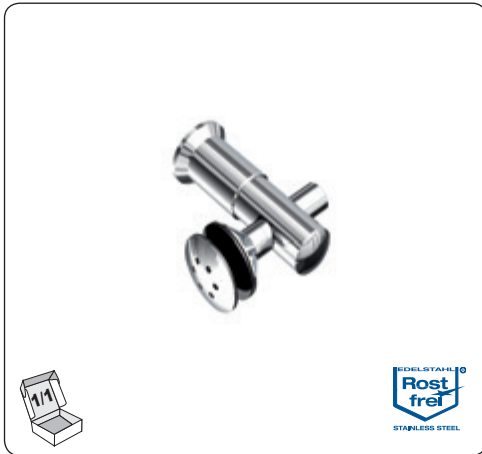

Art. Nr.: 32059

Halter, Glas-Wand 90°, erhaben

Plattenstärke: 8-12 mm

Material/Oberfläche VA = Edelstahl



VA



VA1 auf Anfrage

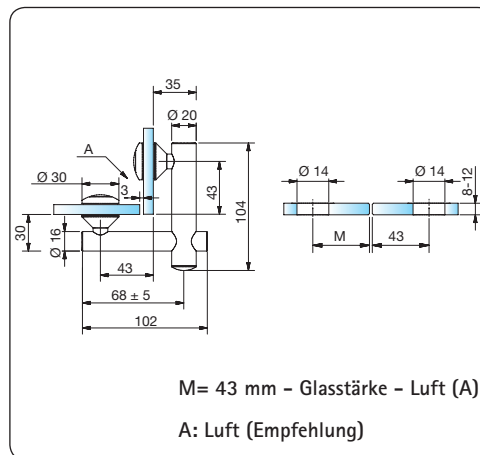
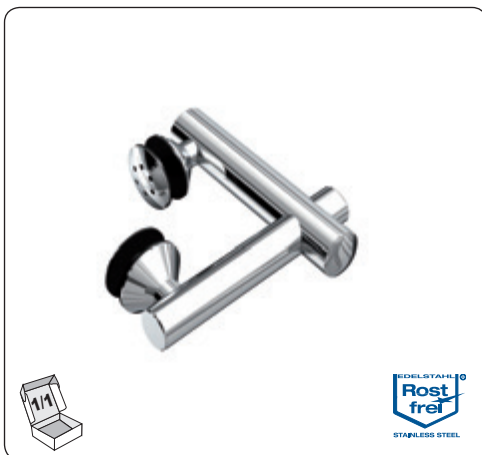

Art. Nr.: 32061

Eckverbinder, Glas-Glas 90°, erhaben

Plattenstärke: 8-12 mm

Material/Oberfläche VA = Edelstahl



VA



VA1 auf Anfrage

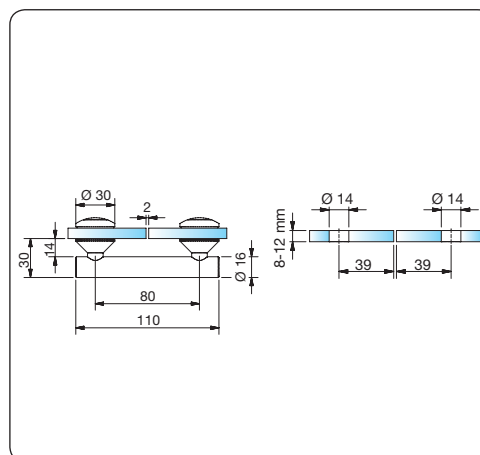
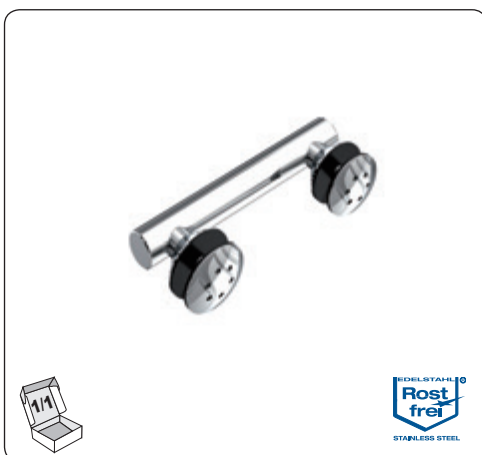

Art. Nr.: 32063

Längsverbinder, Glas-Glas 180°, erhaben

Plattenstärke: 8-12 mm

Material/Oberfläche VA = Edelstahl



VA



VA1 auf Anfrage



Zubehör

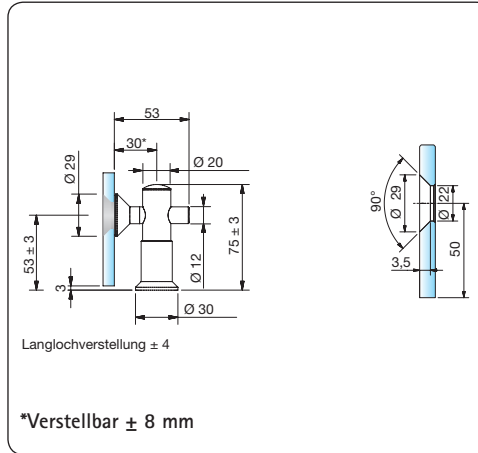

Art. Nr.: 32058

Halter, Glas-Wand 90°, flächenbündig

Plattenstärke: 8-12 mm

Material/Oberfläche VA = Edelstahl



VA



VA1 auf Anfrage

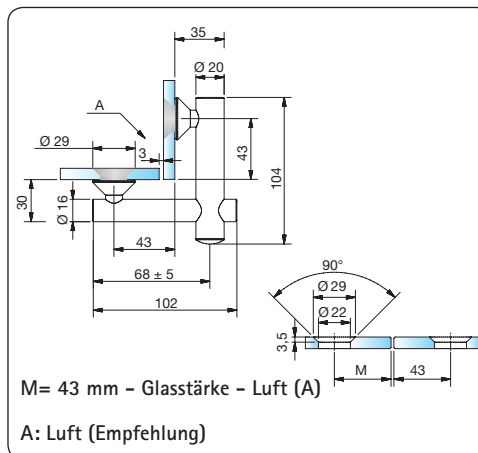

Art. Nr.: 32060

Eckverbinder, Glas-Glas 90°, flächenbündig

Plattenstärke: 8-12 mm

Material/Oberfläche VA = Edelstahl



VA



VA1 auf Anfrage

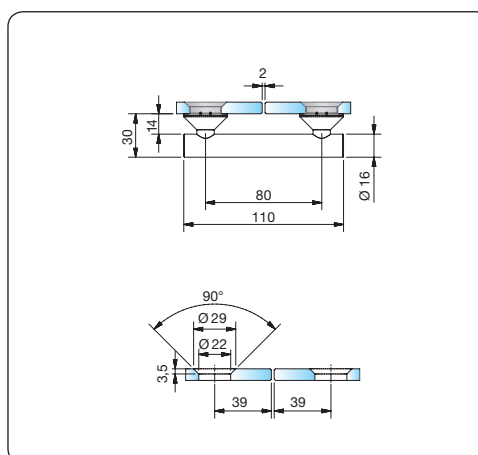

Art. Nr.: 32062

Längsverbinder, Glas-Glas 180°, flächenbündig

Plattenstärke: 8-12 mm

Material/Oberfläche VA = Edelstahl



VA



VA1 auf Anfrage





■ Typenübersicht Glastüranlagen PS100/PS200/PS300

Türflügel – Wand

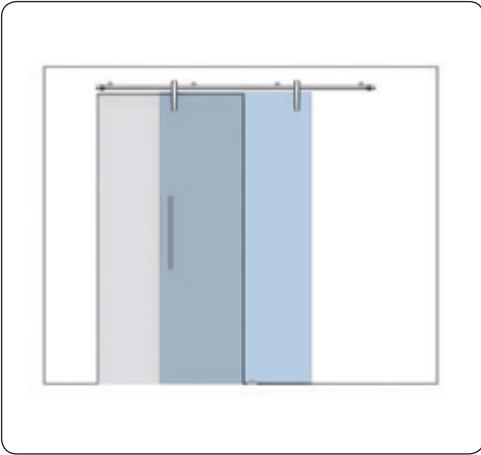

Typ 1 einflügelig, Wandanschluss

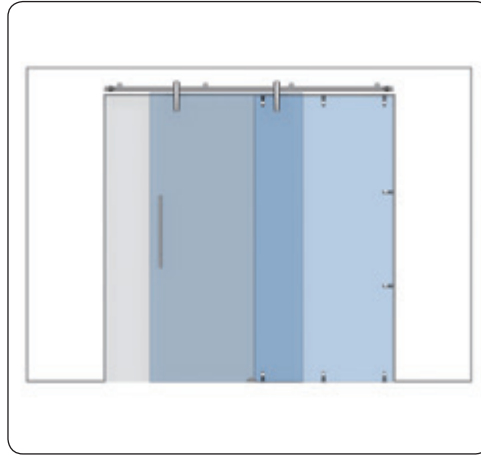

Typ 2 einflügelig, Wandanschluss, Seitenteil

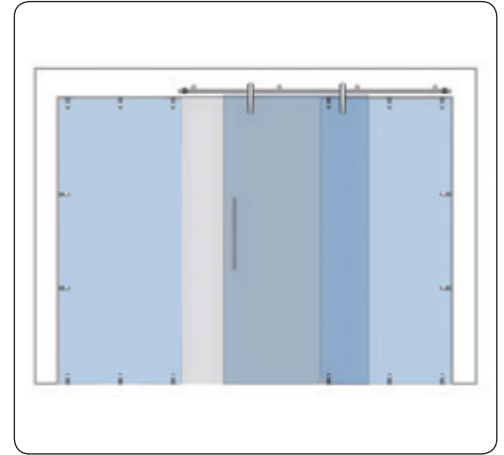

Typ 3 einflügelig, Wandanschluss, 2x Seitenteile

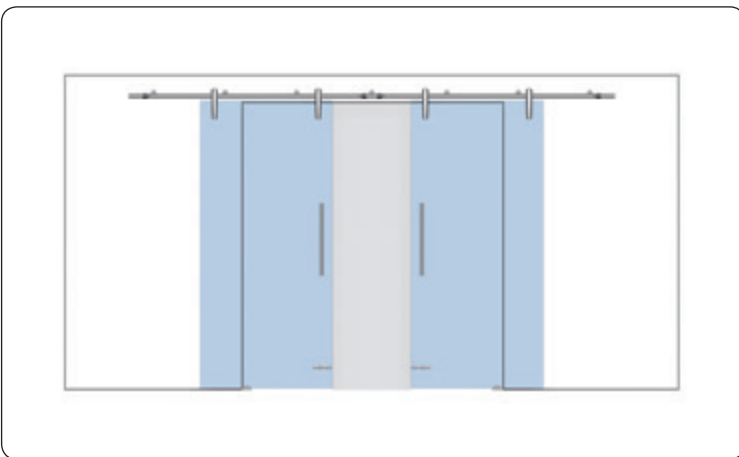

Typ 4 zweiflügelig, Wandanschluss

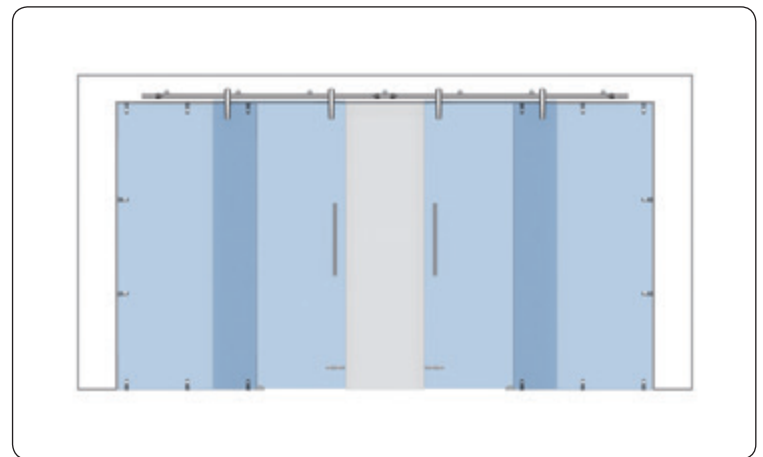

Typ 5 zweiflügelig, Wandanschluss, 2x Seitenteile



■ Typenübersicht Glastüranlagen PS100/PS200/PS300

Türflügel - Glas

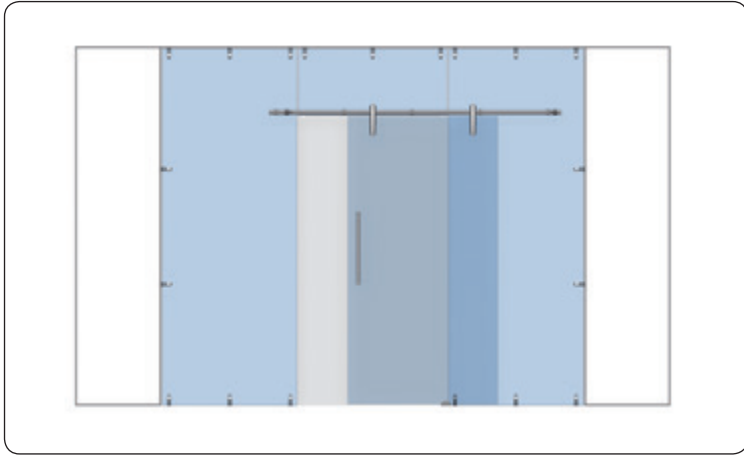

Typ 6 einflügelig, Glasanschluss, 2x Seitenteile, Oberlicht

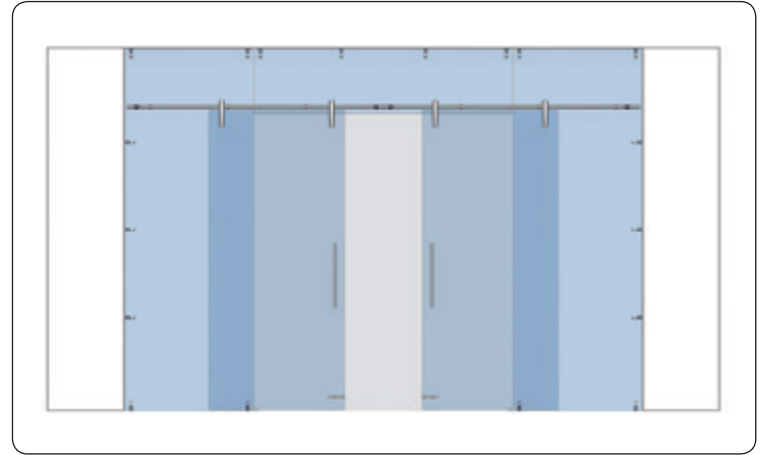

Typ 7 zweiflügelig, Glasanschluss, 2x Seitenteile, Oberlicht

Türflügel - Kombination

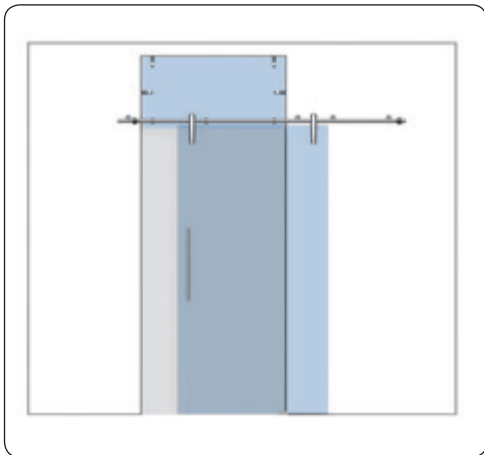

Typ 8 einflügelig, Anschluss Glas-Wand, Oberlicht

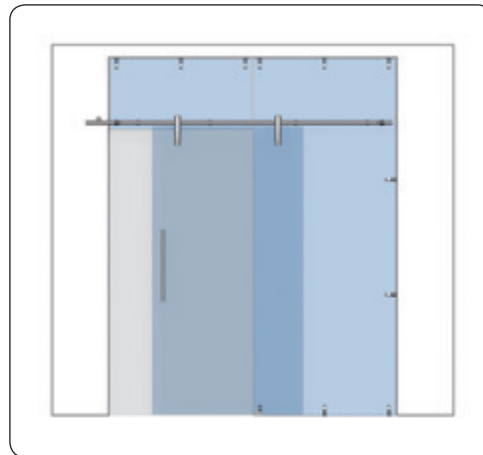

Typ 9 einflügelig, Anschluss Glas-Wand, Seitenteil, Oberlicht

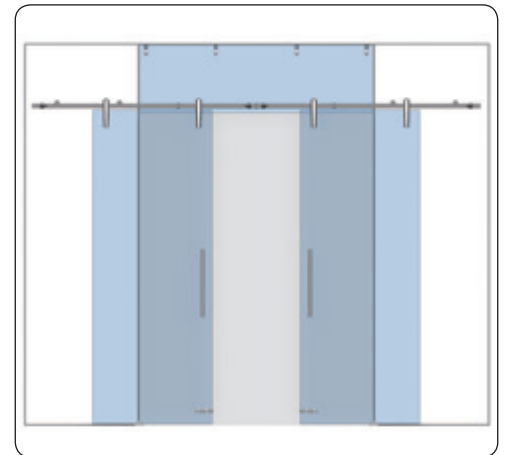

Typ 10 zweiflügelig, Anschluss Glas-Wand, Oberlicht



■ Typenübersicht Glastüranlagen PS100/PS200/PS300

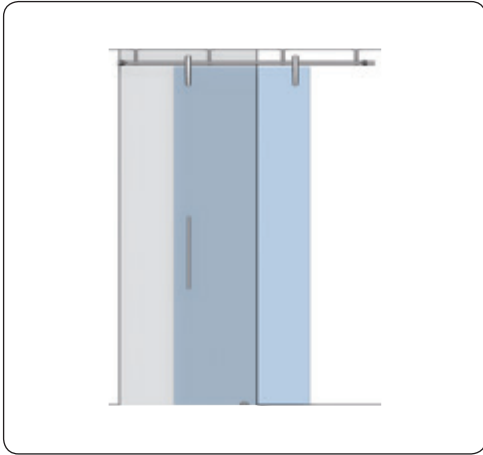

Typ 11 einflügelig, Deckenanschluss

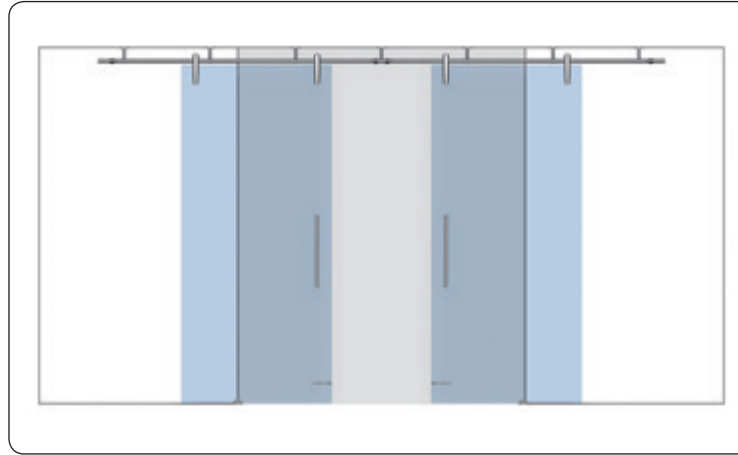

Typ 12 zweiflügelig, Deckenanschluss

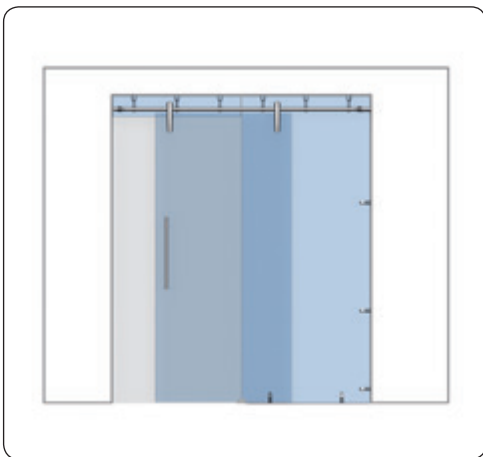

Typ 13 einflügelig, Deckenanschluss,
Seitenteil, Oberlicht

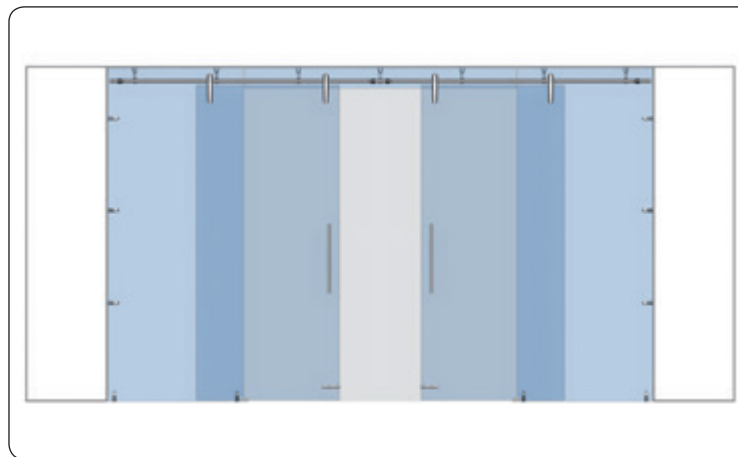

Typ 14 zweiflügelig, Deckenanschluss, 2 x Seitenteile, Oberlicht



Sets PS100/PS200/PS300



1x
 Laufschiene Ø 25 mm, Länge 2000 mm
 Ausführung: Edelstahlrohr inkl. Endkappe
 32005VA2

5x
 32004ZN

1x
 32031VA-L

1x
 32031VA-R

1x
 32020ZN-8

1x
 32024VA

Set-203VA-P

2x
 PS100 mit 32072VA

Set-201ZN22-P

2x
 PS200 mit 32008ZN

Set-204VA*-P

2x
 PS300 mit 32082VA



1x
 Laufschiene Ø 25 mm, Länge > 2601 mm
 Ausführung: Edelstahlrohr inkl. Endkappen, bis 5000 mm
 32005VA2-V

8x
 32004ZN

2x
 32031VA-L

2x
 32031VA-R

2x
 32020ZN-8

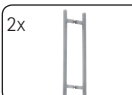
2x
 32024VA

1x
 32026VA-8

Set-205VA-P

4x
 PS100 mit 32072VA

Set-202ZN22-P

4x
 PS200 mit 32008ZN

Set-206VA*-P

4x
 PS300 mit 32082VA

* Inlayoberflächen siehe Seite 23.



■ Set PS200 - Typ 1





■ Sets PS100/PS200/PS300

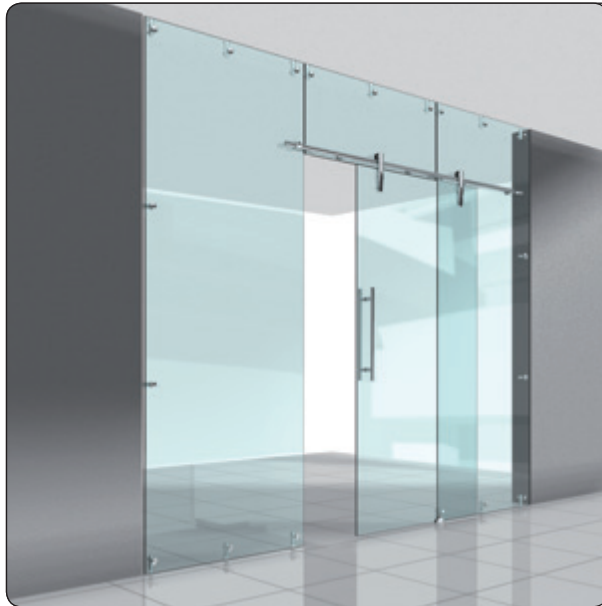

1x Laufschiene Ø 25 mm,
Länge 2000 mm
Ausführung: Edelstahl massiv

32016VA-2000



32034VA

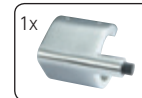

32031VA-L

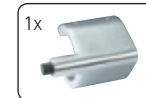

32031VA-R



32020ZN-8

Griff, Befestigung für Seitenteil und Oberlicht
nicht im Set enthalten.

Set-605VA

2x PS100 mit
32070VA

Set-601ZN22

2x PS200 mit
32002ZN

Set-606VA*

2x PS300 mit
32080VA

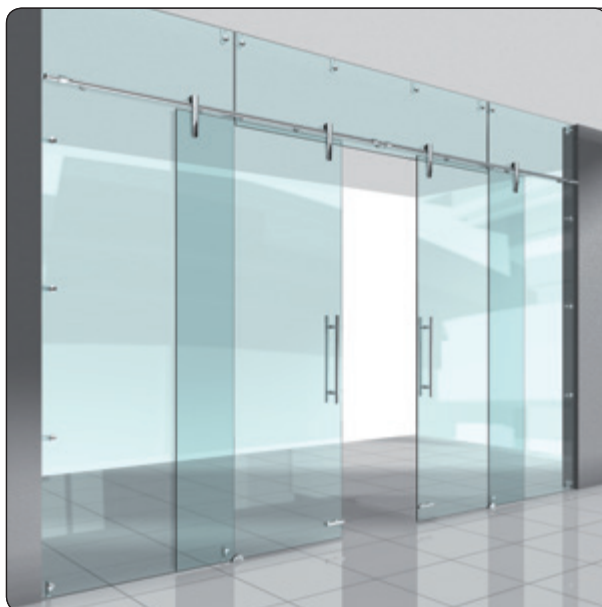

1x Laufschiene Ø 25 mm,
Länge > 2601 mm
Ausführung: Edelstahl massiv,
max. 5000 mm

32016VA-V



32034VA



32031VA-L

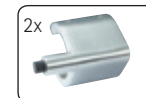

32031VA-R



32020ZN-8



32023VA

Griff, Befestigung für Seitenteil und Oberlicht
nicht im Set enthalten.

Set-607VA

4x PS100 mit
32070VA

Set-602ZN22

4x PS200 mit
32002ZN

Set-608VA*

4x PS300 mit
32080VA

* Inlayoberflächen siehe Seite 23.



■ Sets PS100/PS200/PS300



1x  Laufschiene Ø 25 mm,
Länge 2000 mm
Ausführung: Edelstahl massiv

32016VA-2000



32052VA



32031VA-L



32031VA-R



32020ZN-8



32035VA

Griff, Befestigung für Seitenteil und Oberlicht
nicht im Set enthalten.

Set-609VA

2x  PS100 mit
32070VA

Set-603ZN22

2x  PS200 mit
32002ZN

Set-610VA*

2x  PS300 mit
32080VA

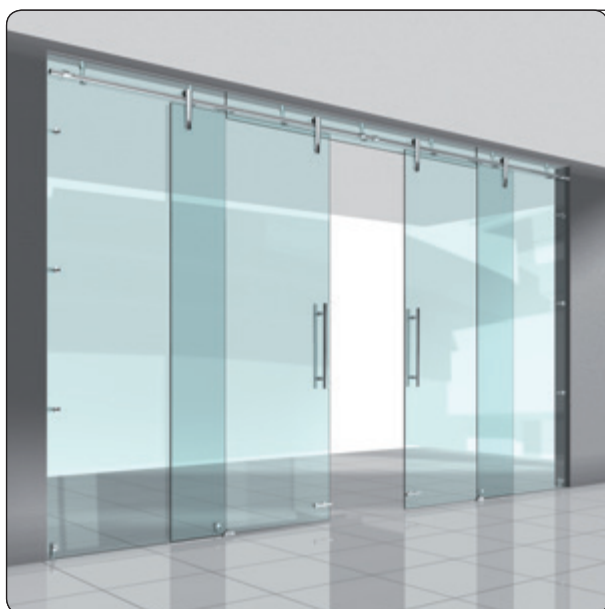

1x  Laufschiene Ø 25 mm,
Länge > 2601 mm
Ausführung: Edelstahl massiv,
bis 5000 mm

32016VA-V



32052VA



32031VA-L



32031VA-R



32020ZN-8



32035VA



32023VA

Griff, Befestigung für Seitenteil und Oberlicht
nicht im Set enthalten.

Set-611VA

4x  PS100 mit
32070VA

Set-604ZN22

4x  PS200 mit
32002ZN

Set-612VA*

4x  PS300 mit
32080VA

* Inlayoberflächen siehe Seite 23.



■ Planungshilfe für Wandbefestigung – PS100/PS200/PS300
Übersicht – Befestigung an der Wand (32004ZN)

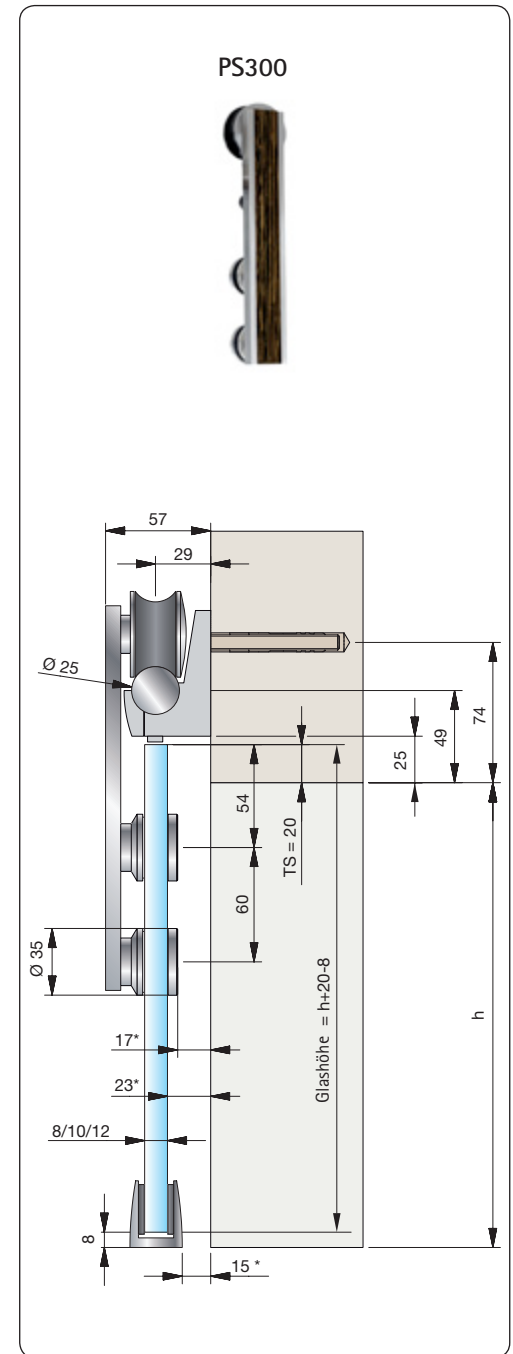
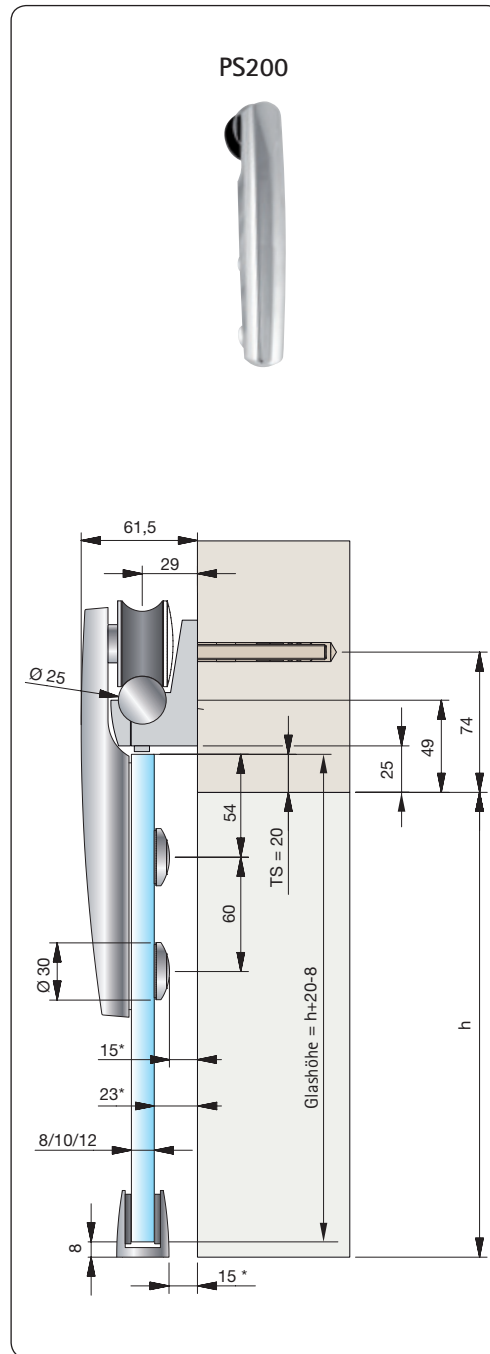
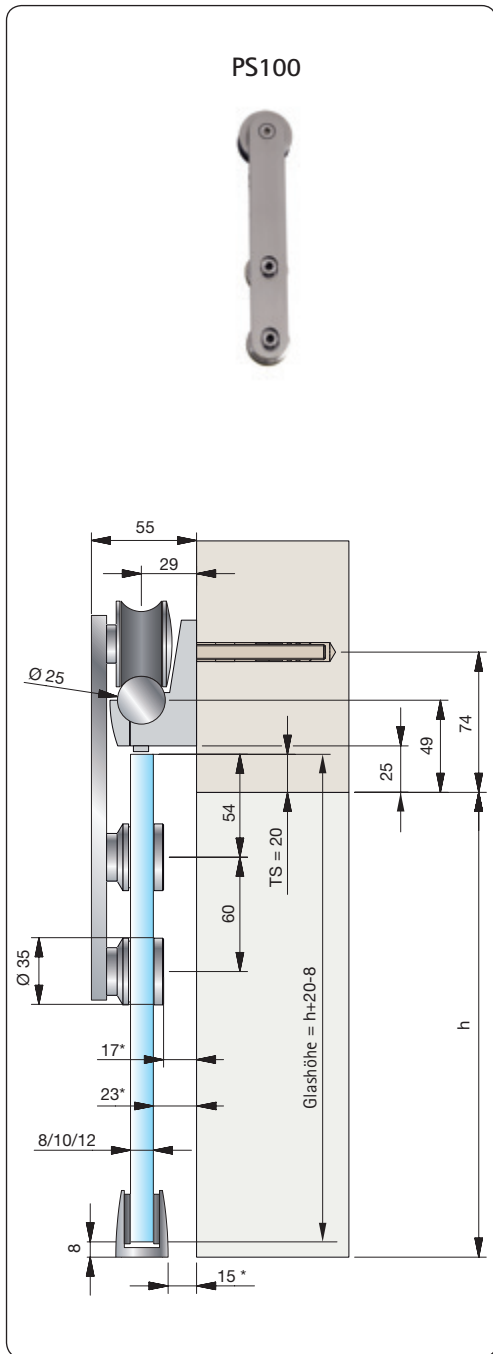

* Bei 12 mm Glasstärke

h = lichte Höhe



■ Planungshilfe für Glasbearbeitung – PS100/PS200/PS300

Übersicht – Befestigung an der Wand (32004ZN)

PS100

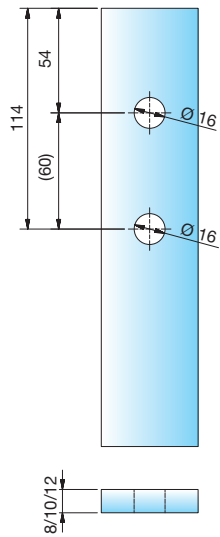

PS200

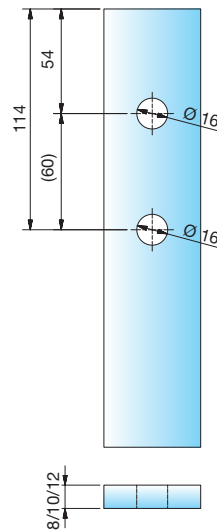

PS300

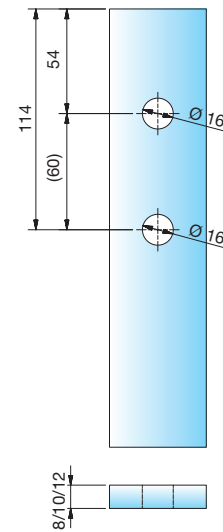



■ Planungshilfe für Wandbefestigung – PS100/PS200/PS300
Übersicht – Befestigung an der Wand (32010ZN)

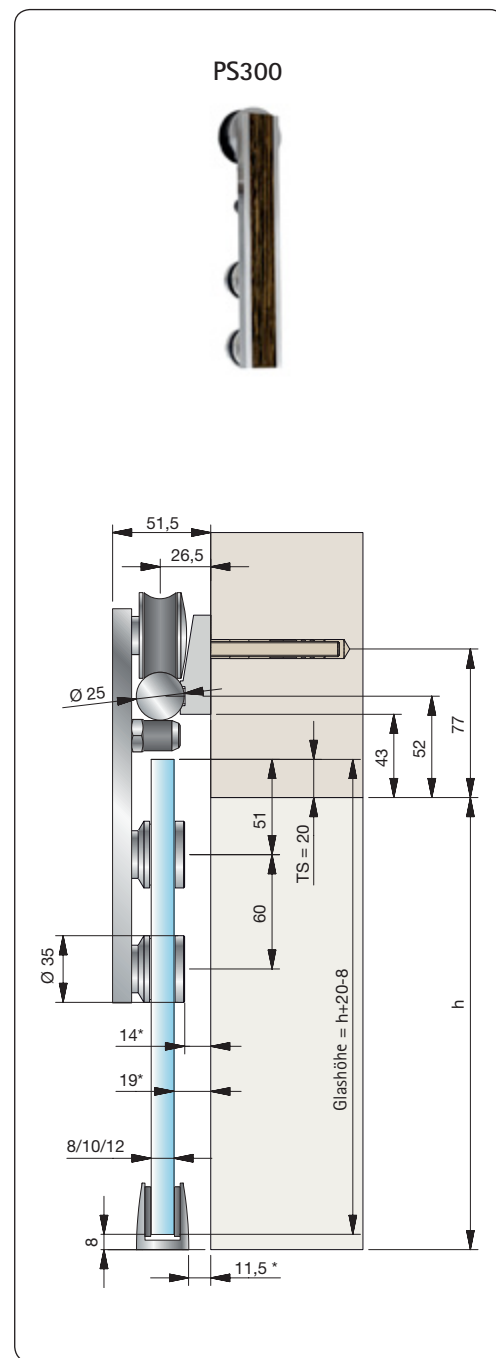
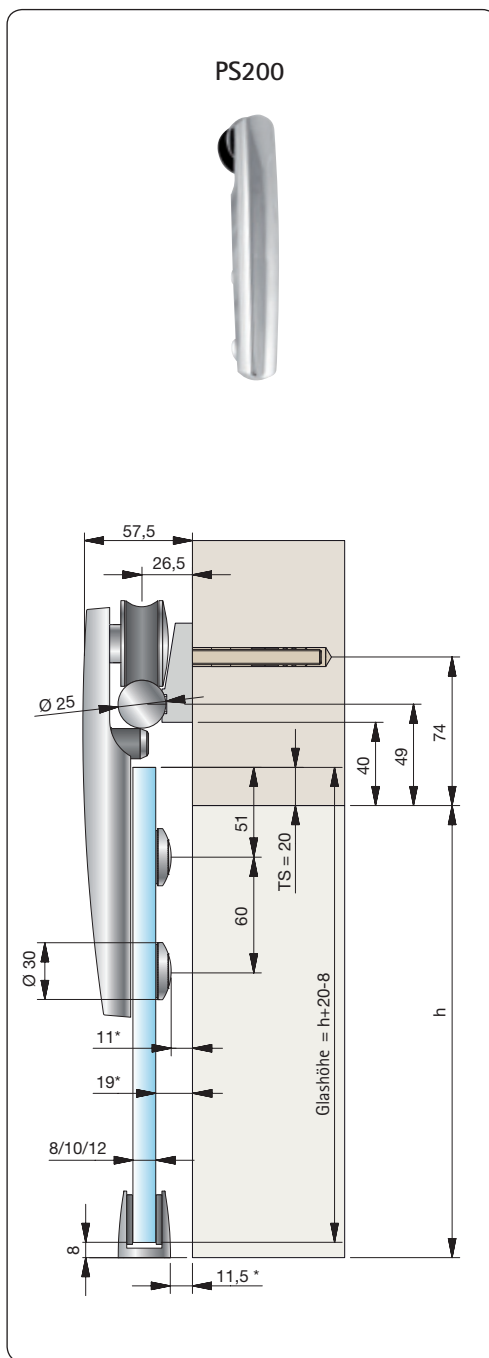
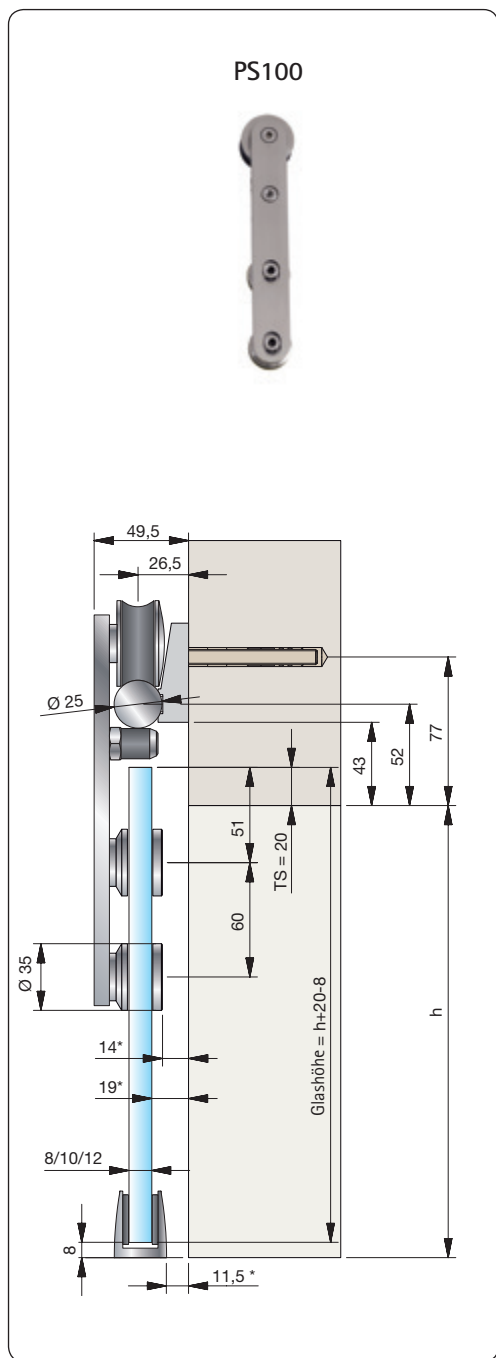

* Bei 12 mm Glasstärke

h = lichte Höhe



■ Planungshilfe für Glasbearbeitung – PS100/PS200/PS300

Übersicht – Befestigung an der Wand (32010ZN)

PS100

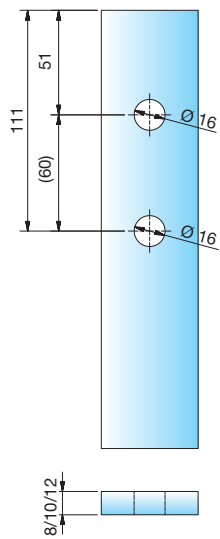

PS200

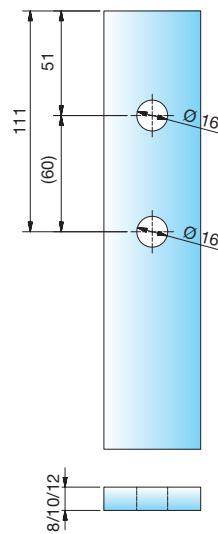

PS300

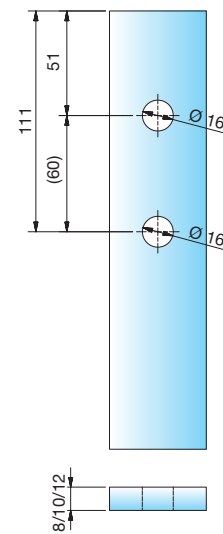



■ Planungshilfe für Glasbefestigung – PS100/PS200/PS300
Übersicht – Befestigung an Glas (32034VA)

PS100

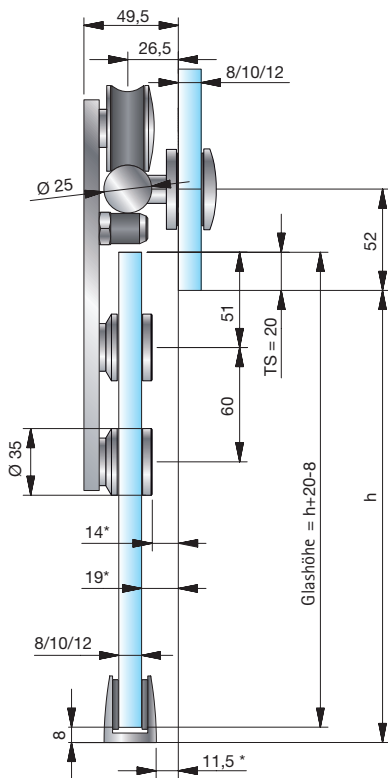

PS200

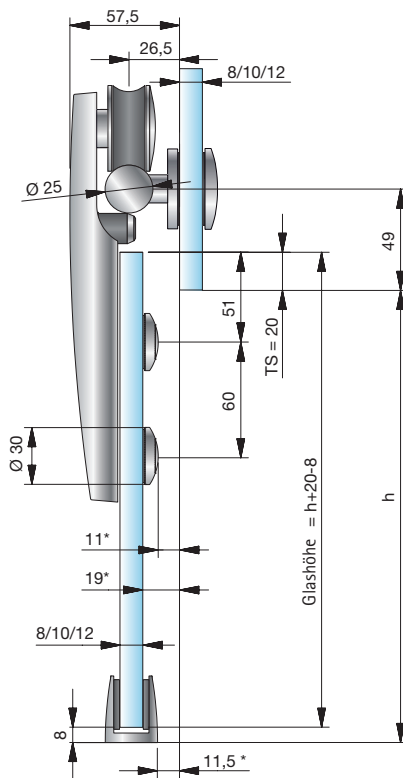

PS300

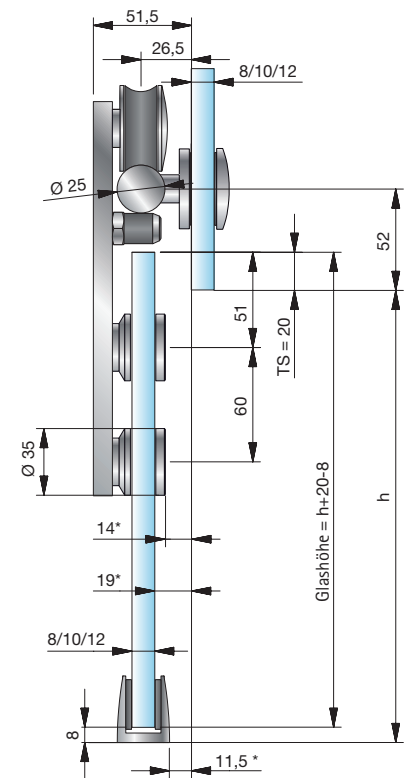

* Bei 12 mm Glasstärke

h = lichte Höhe



■ Planungshilfe für Glasbearbeitung – PS100/PS200/PS300

Übersicht – Befestigung an Glas (32034VA)

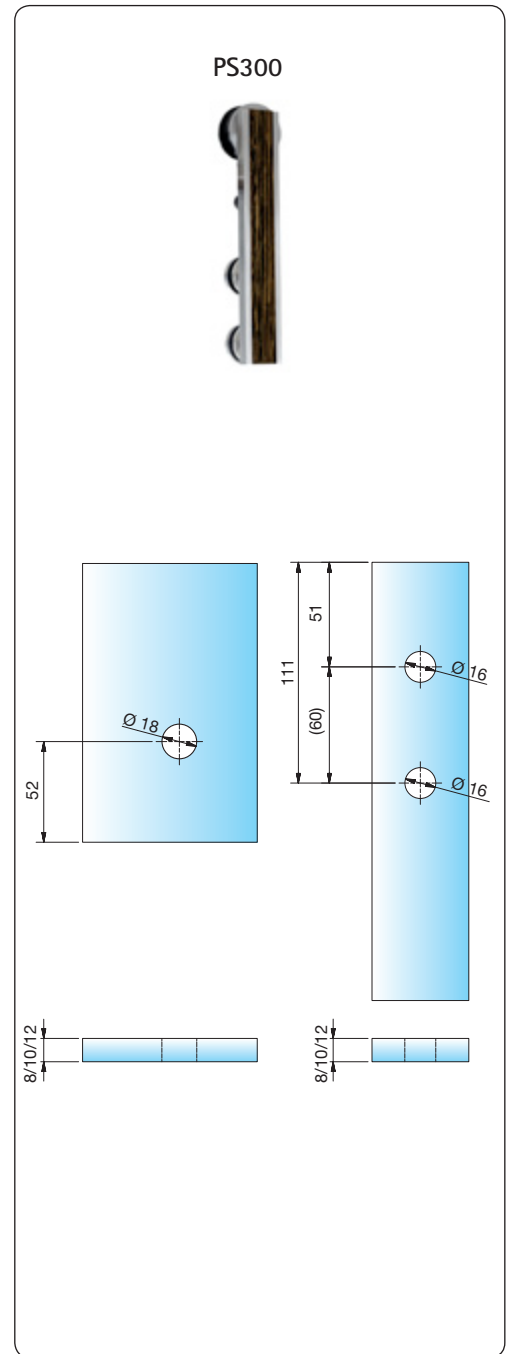
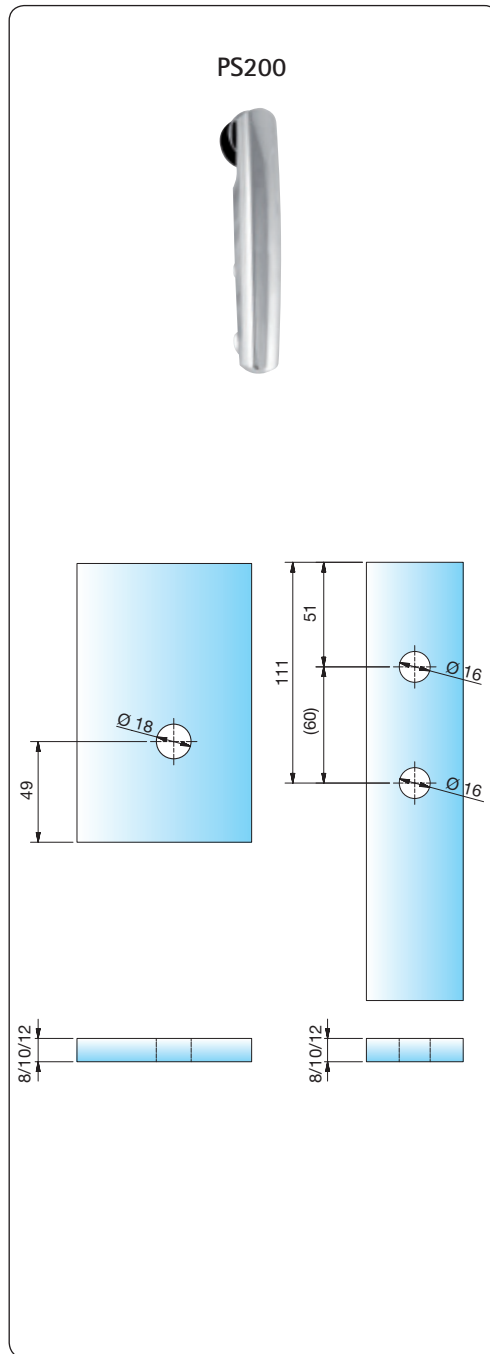
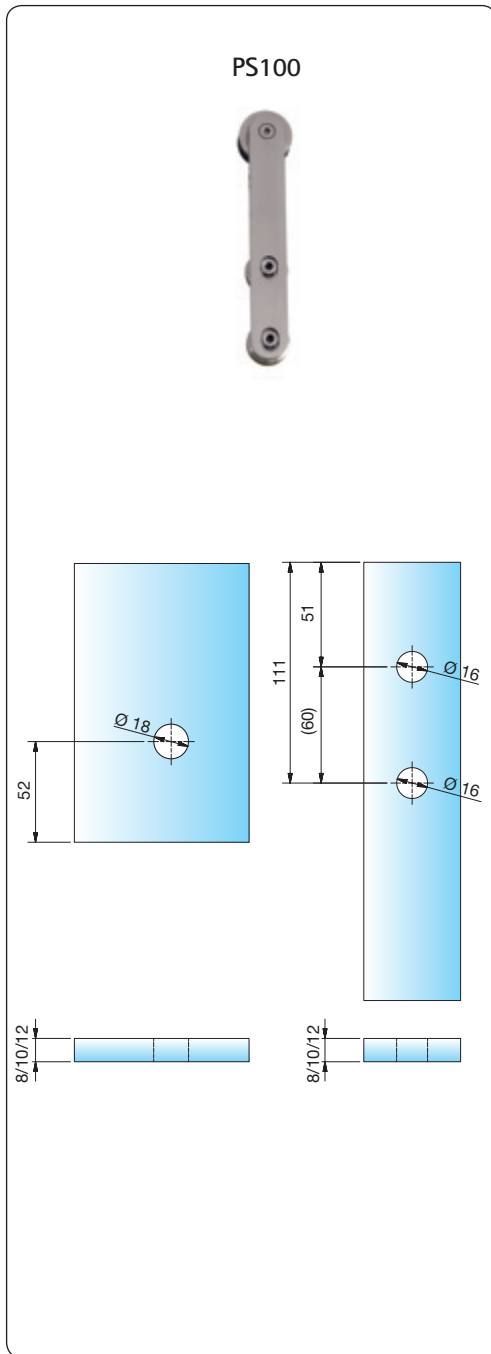



- Planungshilfe für Glasbefestigung – PS100/PS200/PS300
- Übersicht – Befestigung über Deckenabhängung (32052VA) an Glas (32035VA)

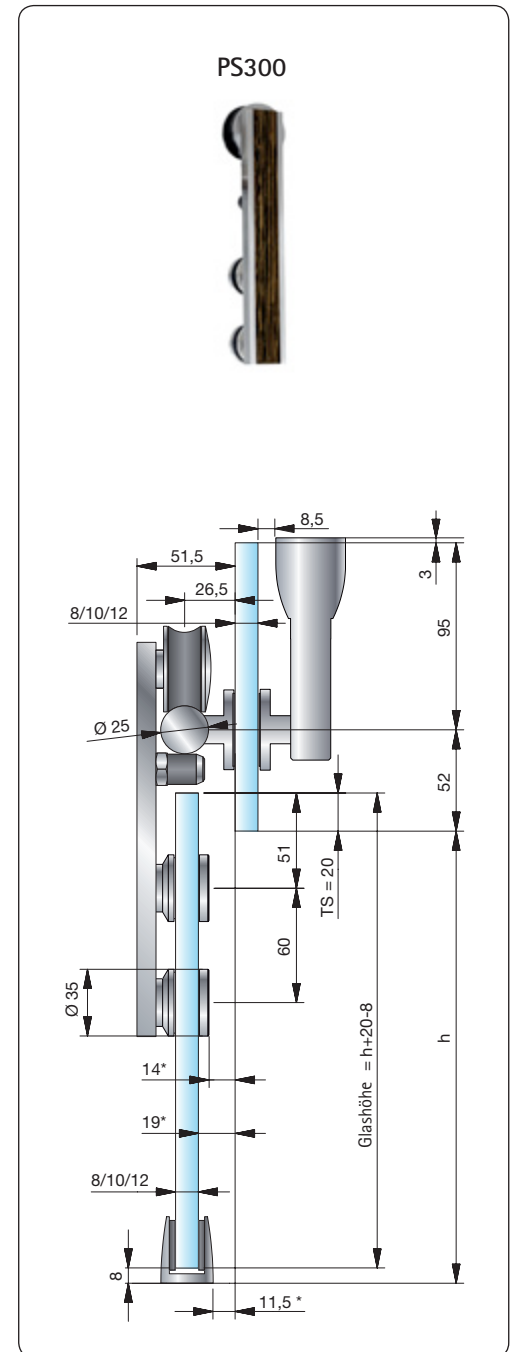
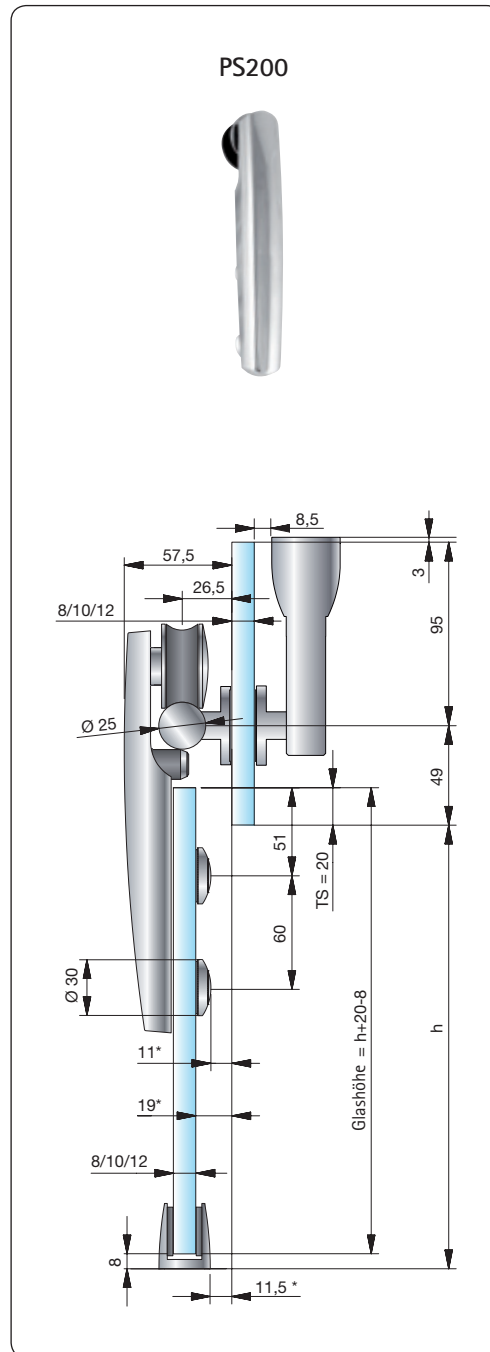
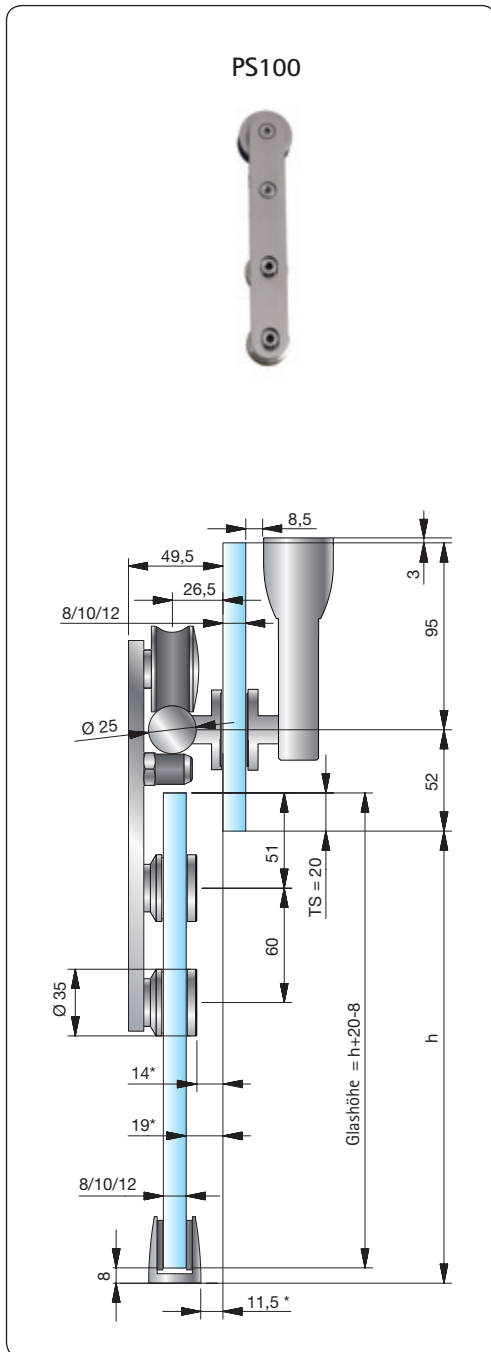

* Bei 12 mm Glasstärke

h = lichte Höhe



■ Planungshilfe für Glasbearbeitung – PS100/PS200/PS300

Übersicht – Befestigung über Deckenabhangung (32052VA) an Glas (32035VA)

PS100

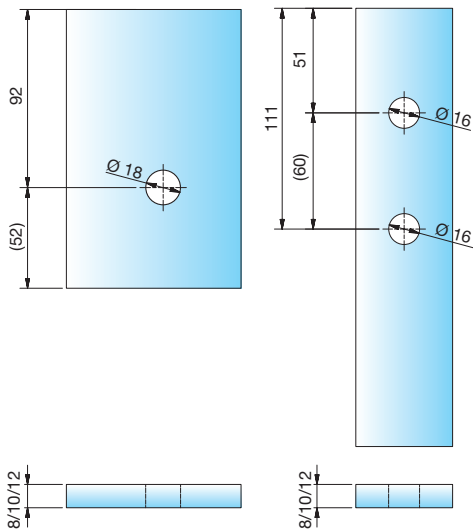

PS200

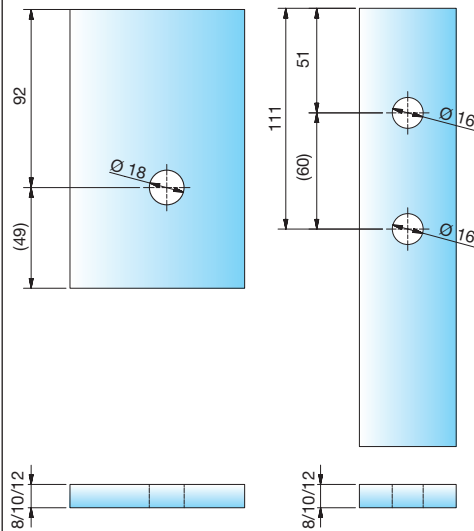

PS300

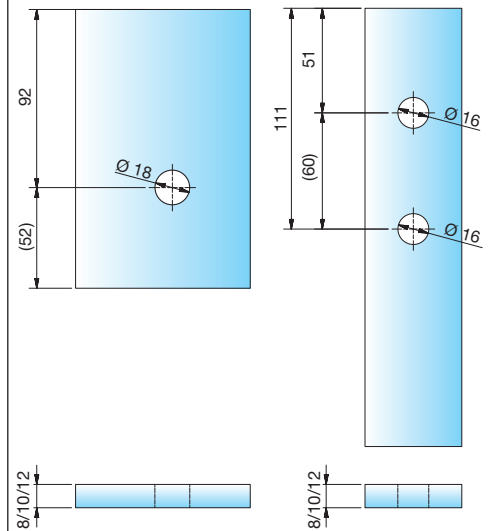



Planungshilfe für Wandbefestigung – PS100/PS200/PS300

Berechnungsbeispiel Set 201

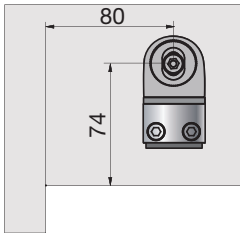

Maß 80 mm nur gültig bei Verwendung von 32031VA-L/-R

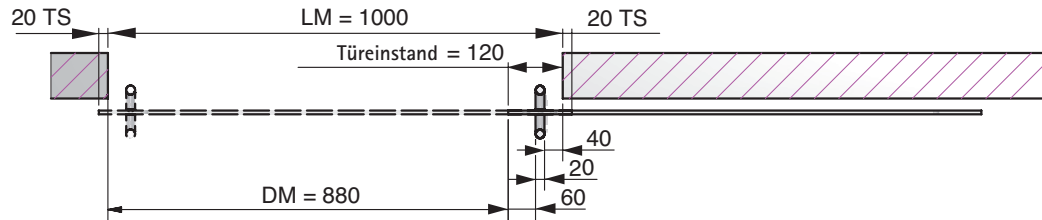

Berechnung des Türeinstandes Beispiel

| | | |
|-------|-----|-----------------------------|
| | 40 | Abstand Türgriff - Wand |
| + | 20 | Griffdurchmesser |
| + | 60 | Abstand Türgriff - Glasrand |
| <hr/> | | |
| = | 120 | Türeinstand |

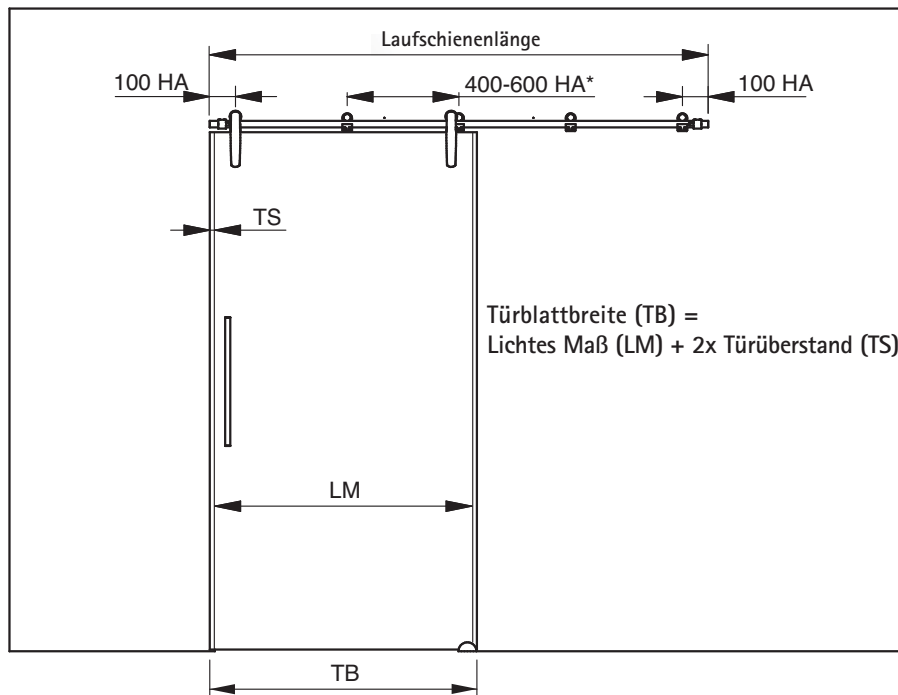

HA = Halterabstand
 LM = Lichtes Maß
 TB = Türblattbreite
 TS = Türüberstand
 DM = Durchgangsöffnung

* Für die Aushebesicherung sind min. 2 Halter oberhalb des Glases notwendig!



■ Planungshilfe für Glasbearbeitung – PS100/PS200/PS300



PS100



PS200



PS300

- HA = Halterabstand
- LM = Lichtes Maß
- TB = Türblattbreite
- TS = Türüberstand
- DM = Durchgangsöffnung
- FW = Fahrweg

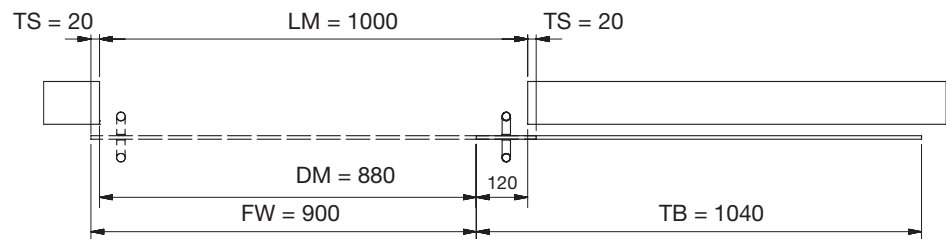
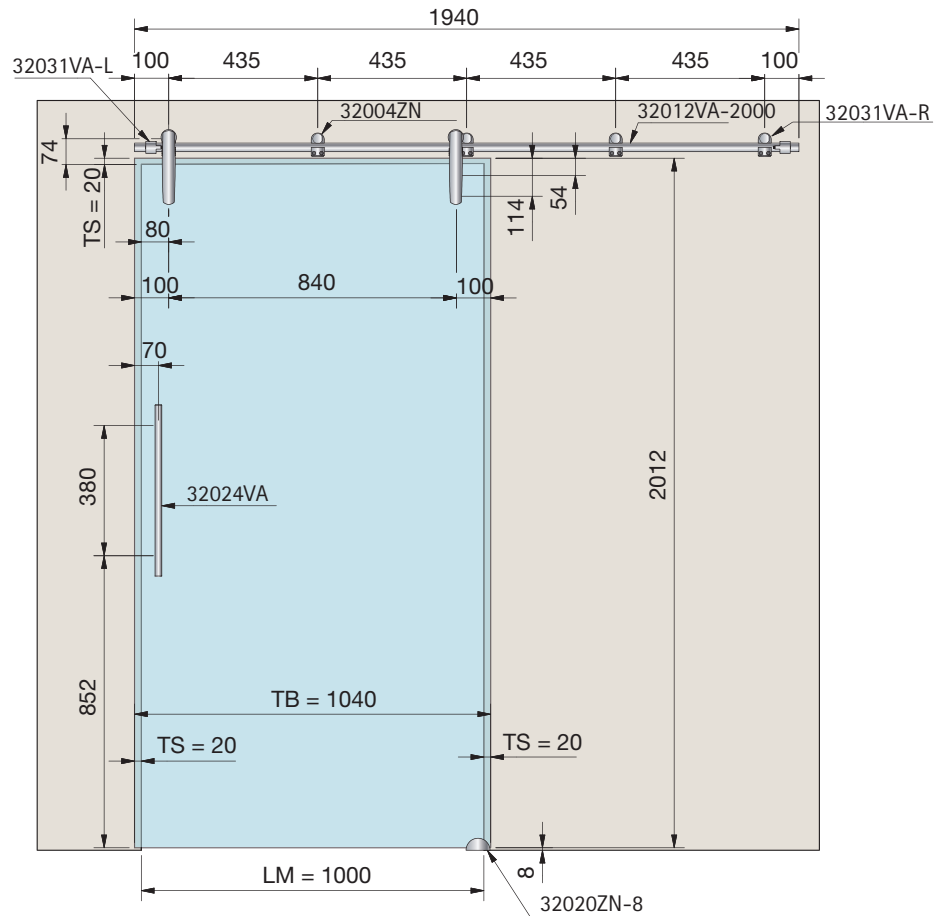

Laufschienenlänge =
 Türblattbreite (TB) x 2 - Türeinstand - 1x Türüberstand (TS)



Planungshilfe für Wandbefestigung – PS100/PS200/PS300

Berechnungsbeispiel Set 202

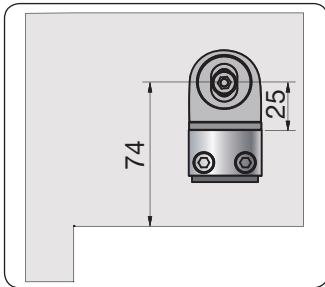

PS100



PS200



PS300

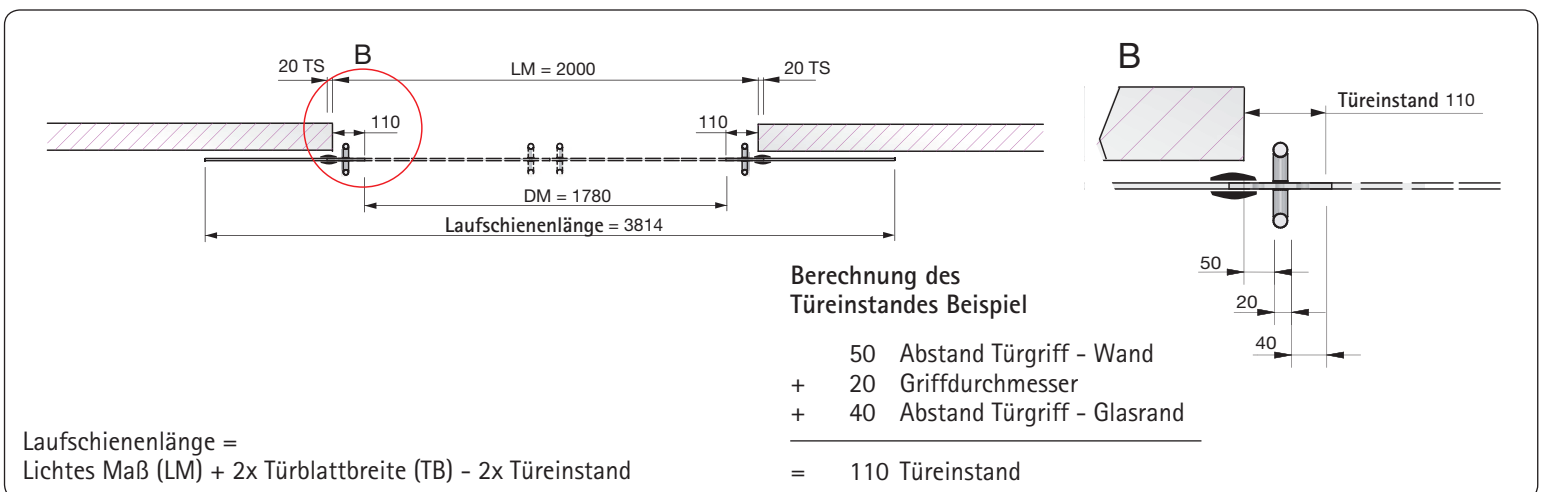
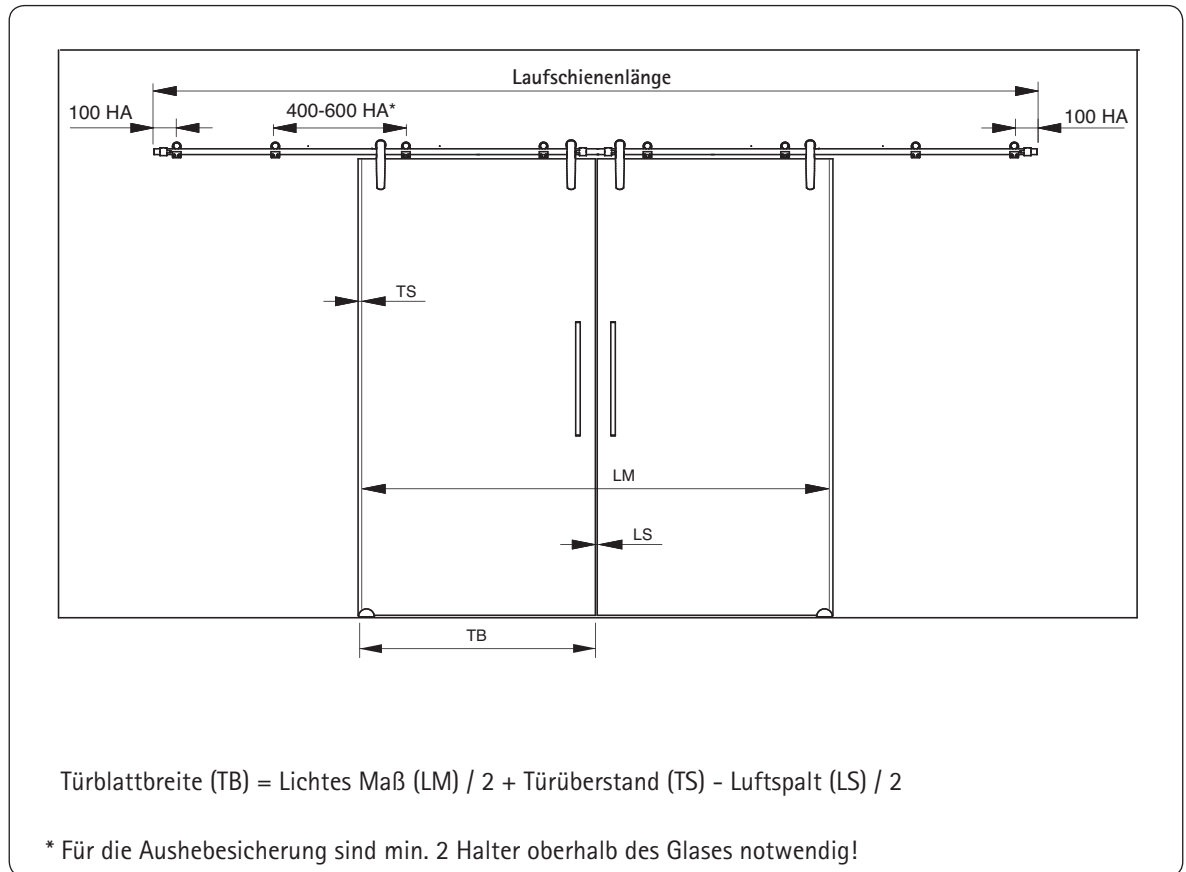



Planungshilfe für Wandbefestigung – PS100/PS200/PS300

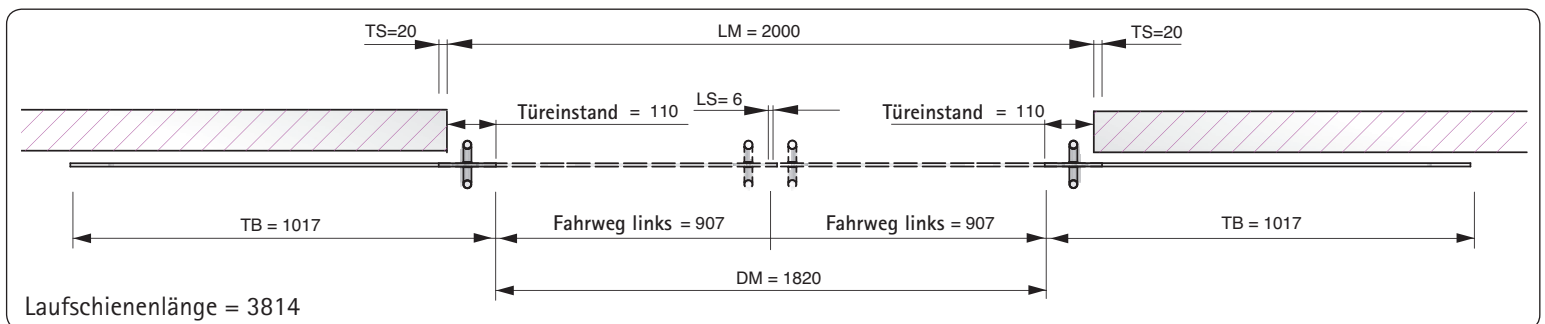
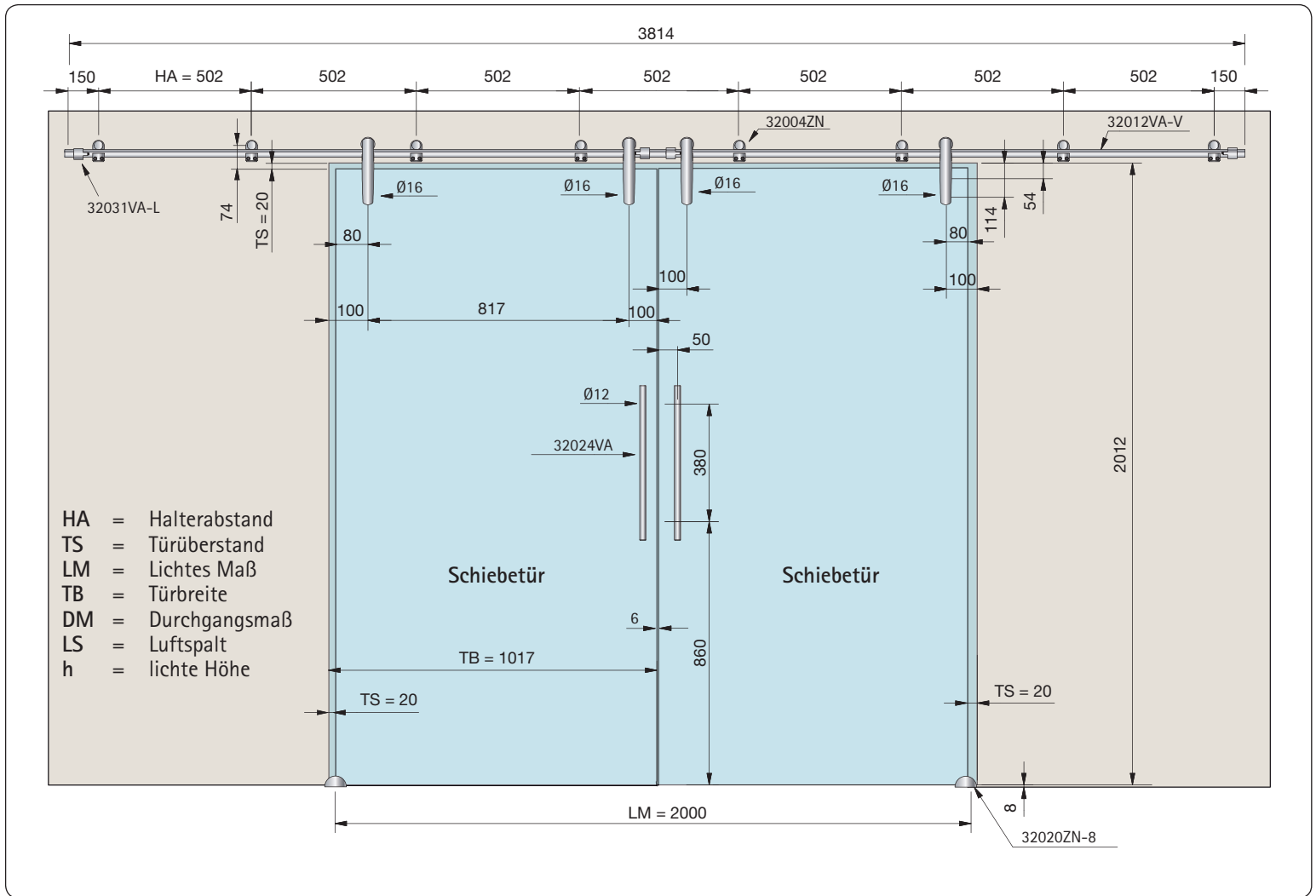



Planungshilfe für Glasbestellung – PS100/PS200/PS300

Beispiel: Aufmaß Glas Türflügel mit Muschelgriff 32028VA, für 32072VA / 32008ZN / 32082VA



PS100



PS200



PS300

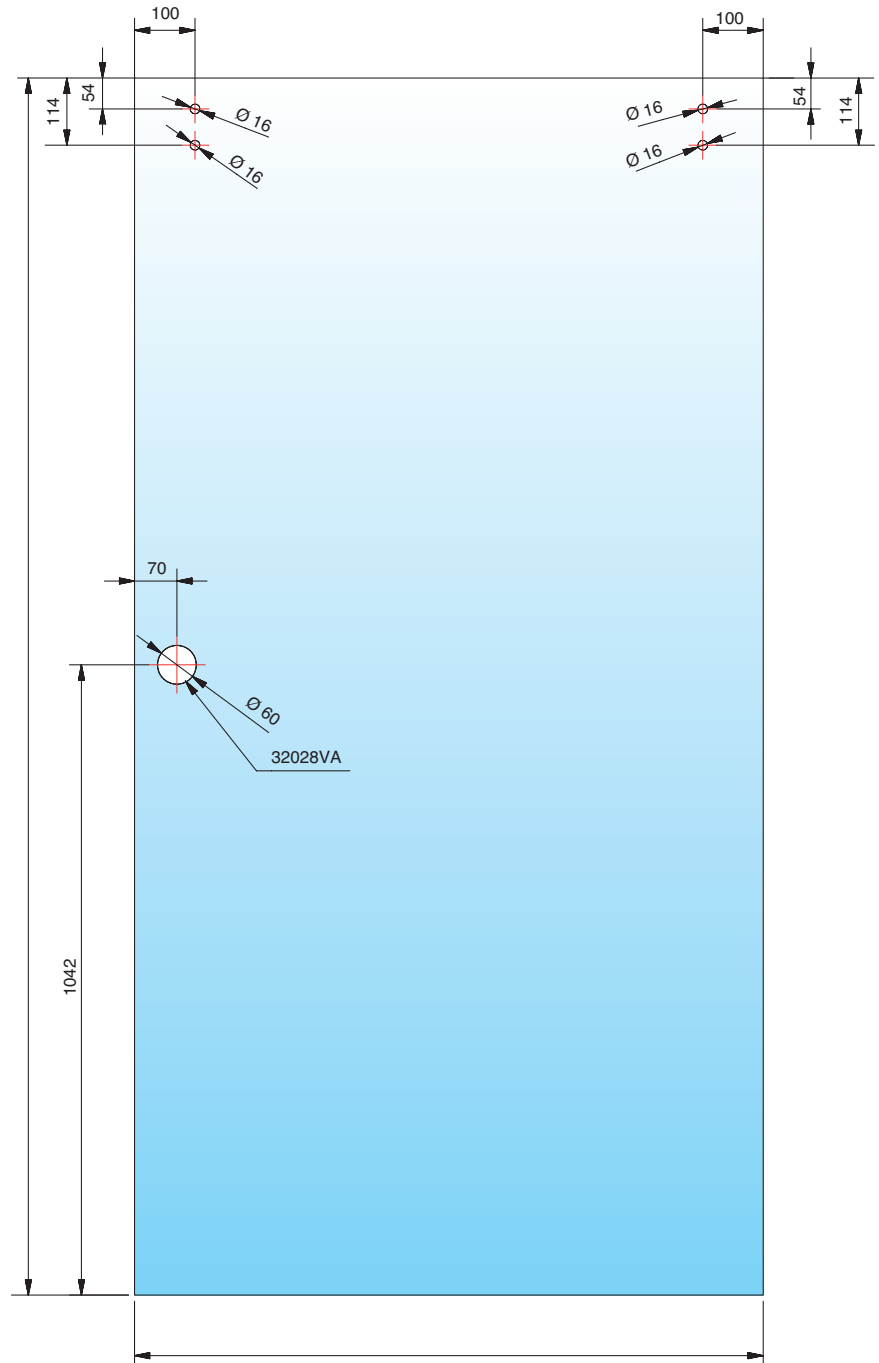

Kanten umlaufend geschliffen und poliert



Planungshilfe für Glasbestellung – PS100/PS200/PS300

Beispiel: Aufmaß Glas Türflügel mit Stoßgriff 32024VA, für 32072VA / 32008ZN / 32082VA



PS100



PS200



PS300

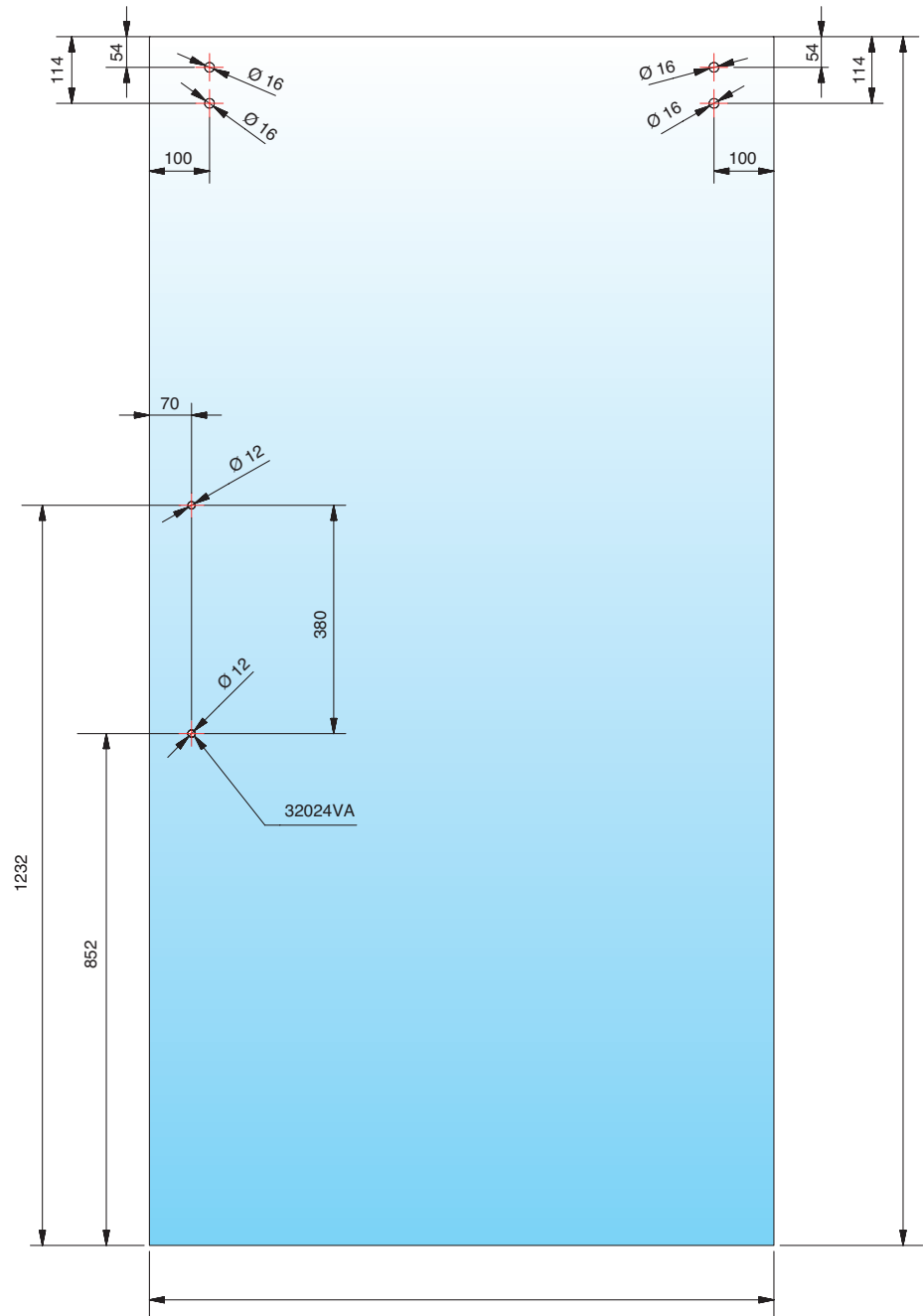

Kanten umlaufend geschliffen und poliert



Planungshilfe für Glasbestellung – PS100/PS200/PS300

Beispiel: Aufmaß Glas Türflügel mit Muschelgriff 32028VA, für 32072VA / 32008ZN / 32082VA

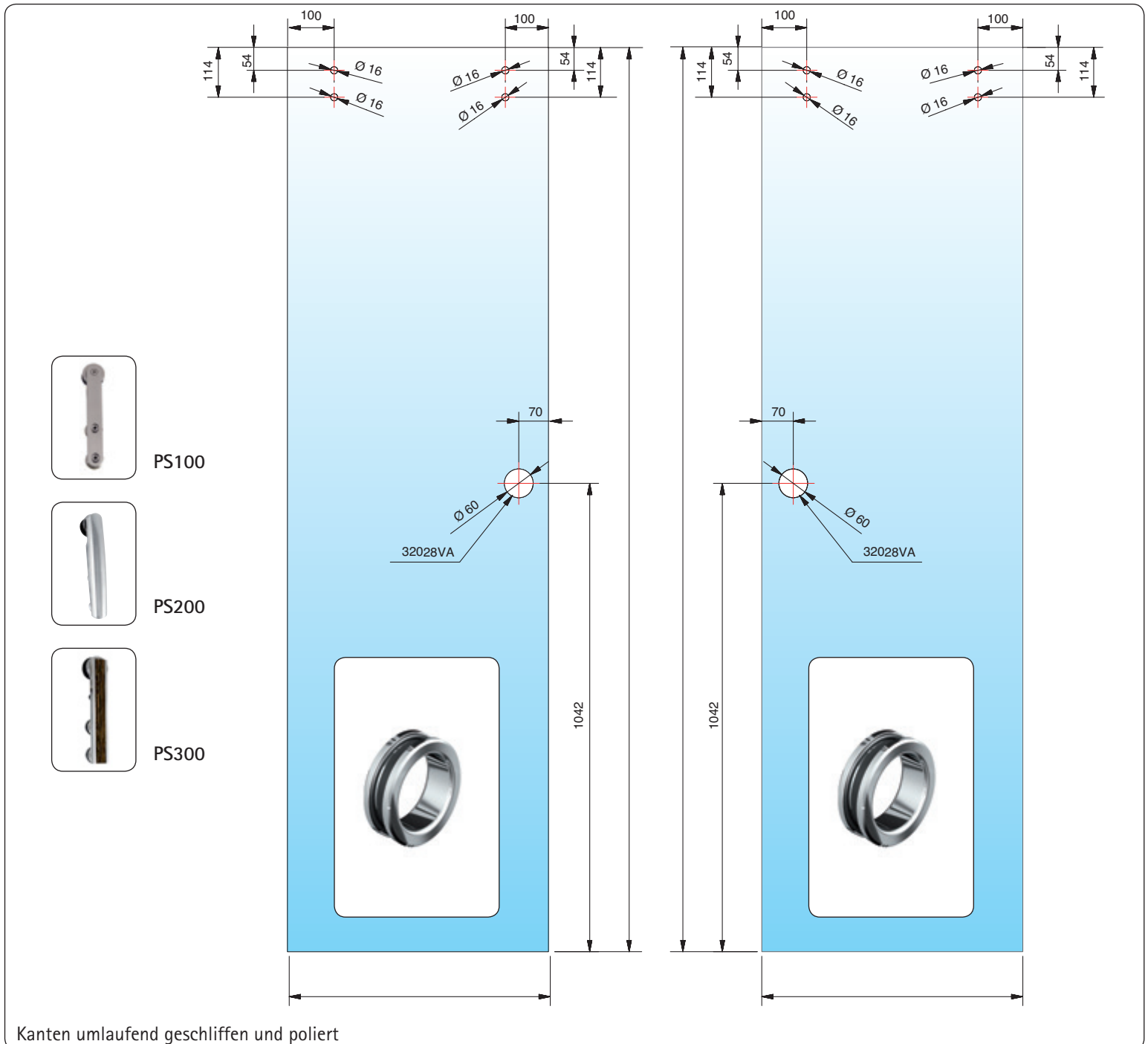



■ Planungshilfe für Glasbestellung – PS100/PS200/PS300

Beispiel: Aufmaß Glas Türflügel mit Stoßgriff 32024VA, für 32072VA / 32008ZN / 32082VA

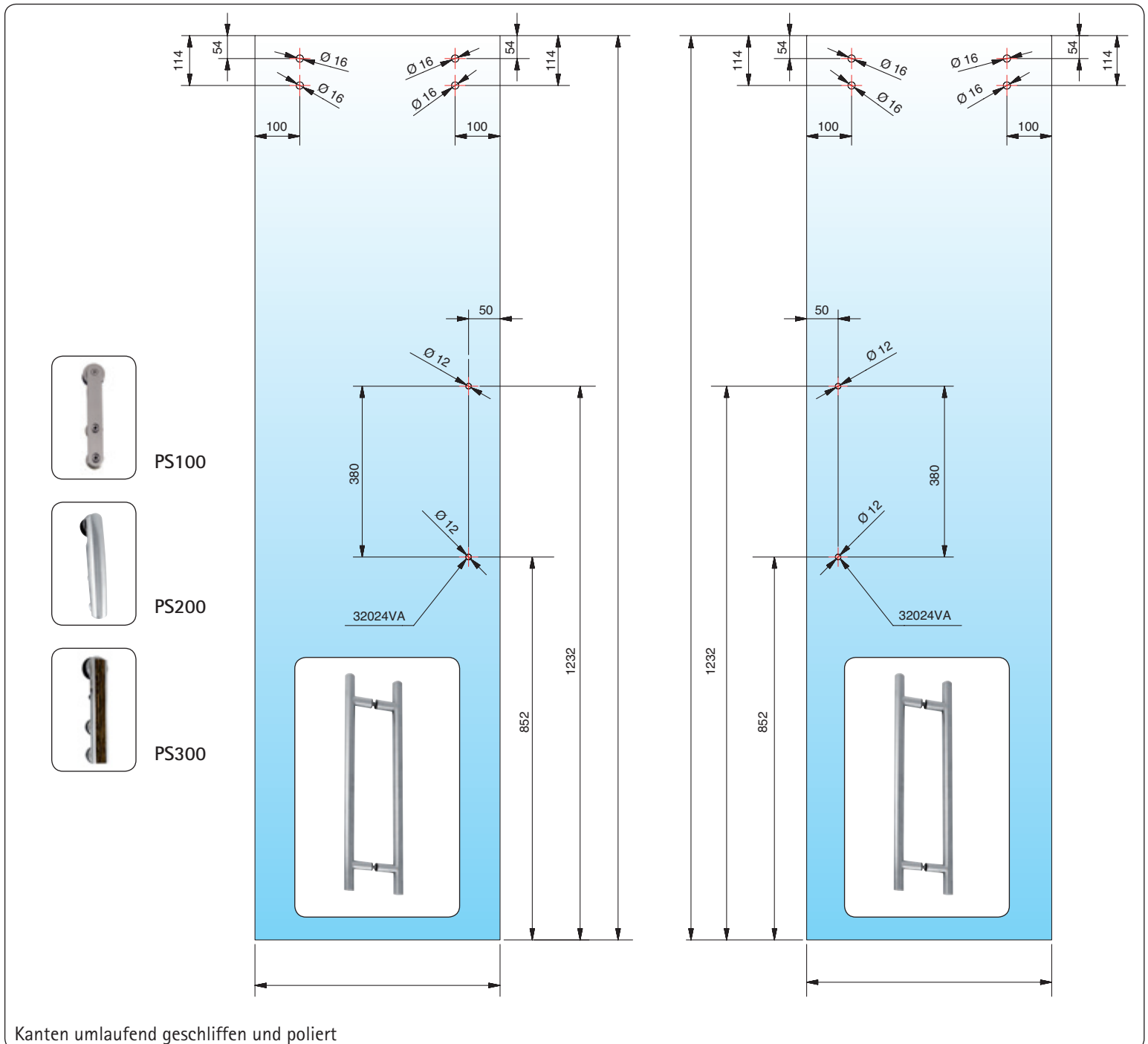



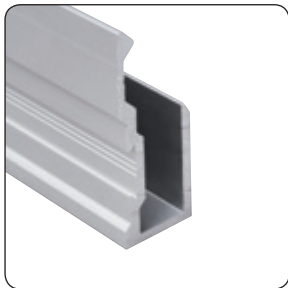

■ Profile und Trennwände



Inhalt

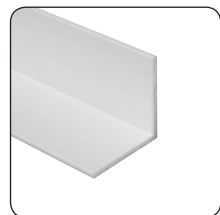

| | | |
|----------------------------|-------|----|
| ■ U-Profil | | 64 |
| Winkelprofil | | 68 |
| Mittelprofil | | 70 |
| Endprofil | | 70 |
| Eckprofil | | 71 |
| Spiegelprofil | | 72 |
| Klemmprofil | | 74 |
| Trennwandstützen | | 78 |
| Winkelverbinder | | 80 |
| Umkleide-/Toilettenkabinen | | 84 |

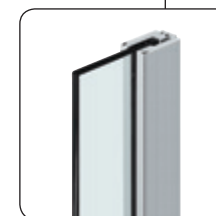
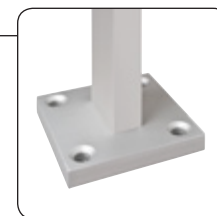
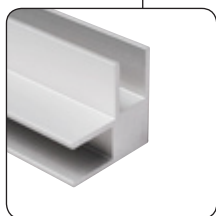
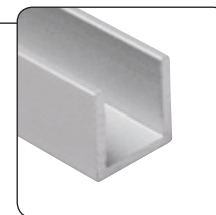

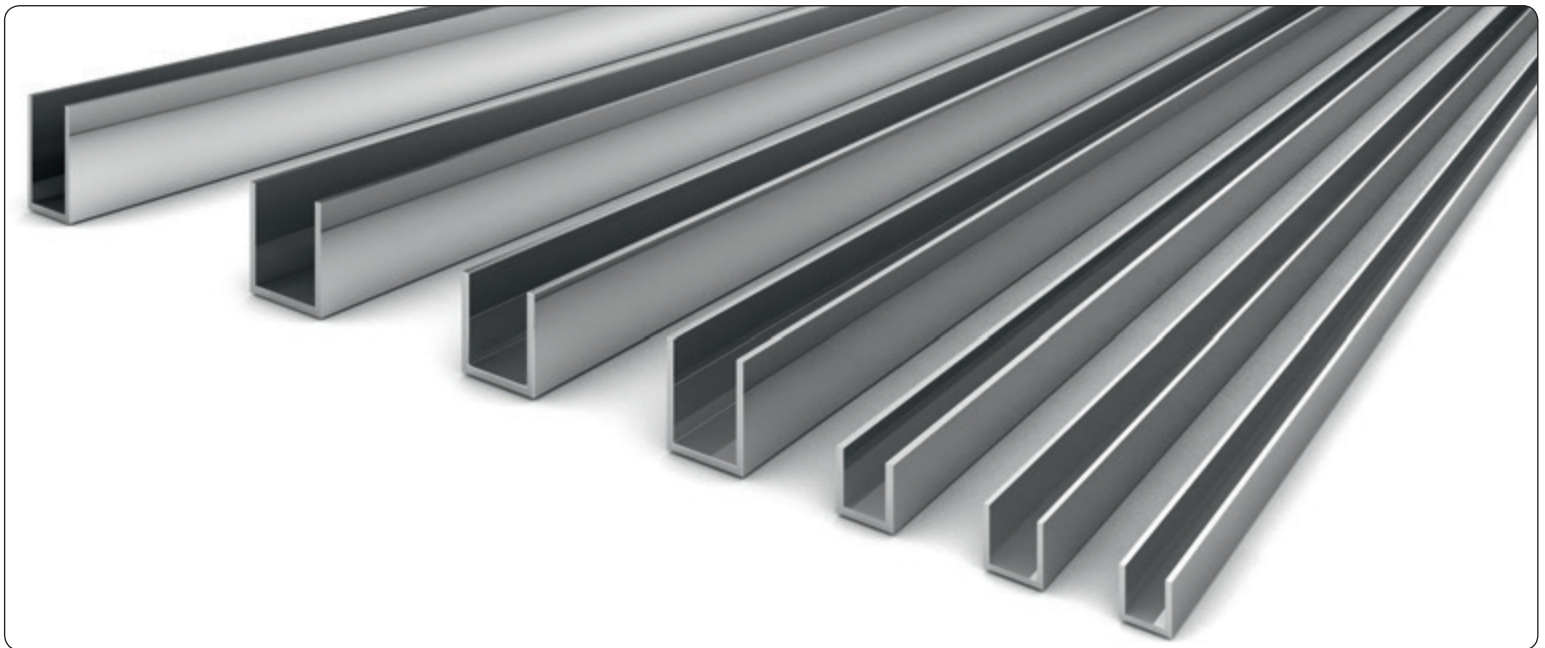
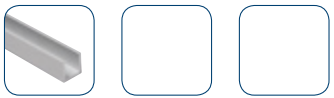



■ Kurzbezeichnungen für Material- und Ausführungsarten

E = Aluminium

| | |
|--|---|
|  | E0/14 = weiß RAL 9016 |
|  | E1/22 = Edelstahloptik (silberfarbig eloxiert, gebürstet) |
|  | E1/23 = Edelstahloptik |
|  | E3/50 = glanzverchromt |
|  | E6/EV1 = Alu-Optik (silberfarbig eloxiert) |
|  | E6/EV5 = glanzeloxiert |

VA = Edelstahl

| | |
|---|----------------------|
|  | VA1 = poliert |
|  | VA2 = matt gebürstet |

KU = Kunststoff

| | |
|---|-----------------------|
|  | KU0 = transparent |
|  | KU1 = weiß |
|  | KU6 = mattverchromt |
|  | KU7 = glanzverchromt |
|  | KU22 = Edelstahloptik |

ZN = Zink (ZAMAK®)

| | |
|--|---------------------------|
|  | ZN1 = mattverchromt |
|  | ZN5 = glanzverchromt |
|  | ZNPVD22 = Edelstahleffekt |

MS = Messing

| | |
|--|---------------------------|
|  | MS7 = glanzverchromt |
|  | MS10 = mattverchromt |
|  | MSPVD22 = Edelstahleffekt |



U-Profil

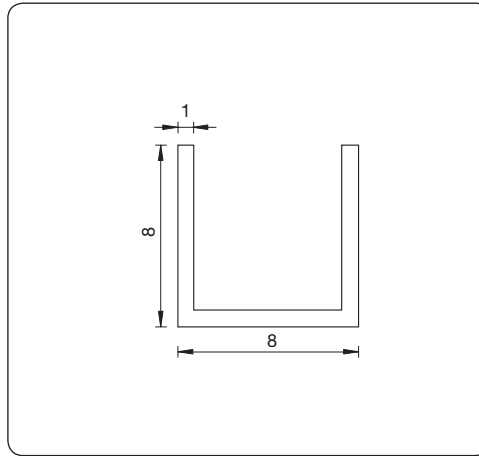
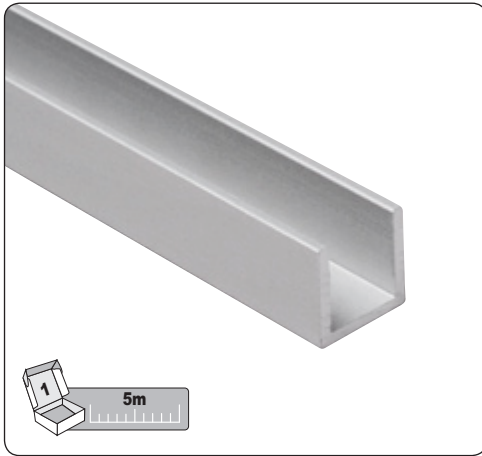

Art. Nr.: 5000

U-Profil 8 x 8 x 5000 x 1 mm

Plattendicke  ≤ 6 mm
Wichtig: + Toleranz nicht möglich

Material/Oberfläche: E = Aluminium



E6/EV1

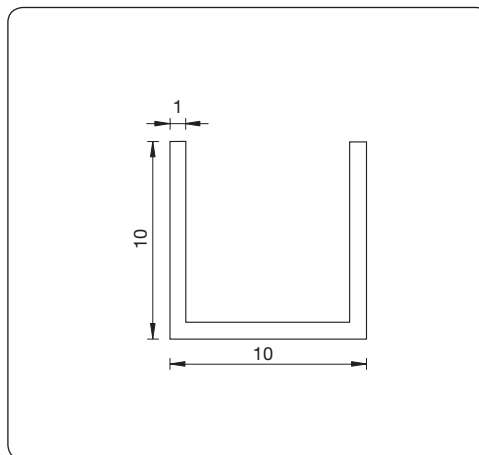
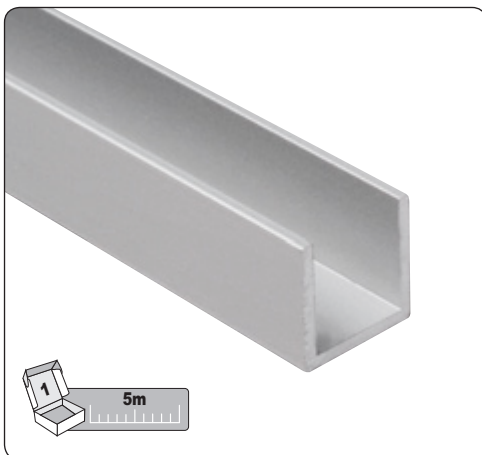

Art. Nr.: 5010

U-Profil 10 x 10 x 5000 x 1 mm

Plattendicke  ≤ 8 mm
Wichtig: + Toleranz nicht möglich

Material/Oberfläche: E = Aluminium



E6/EV1

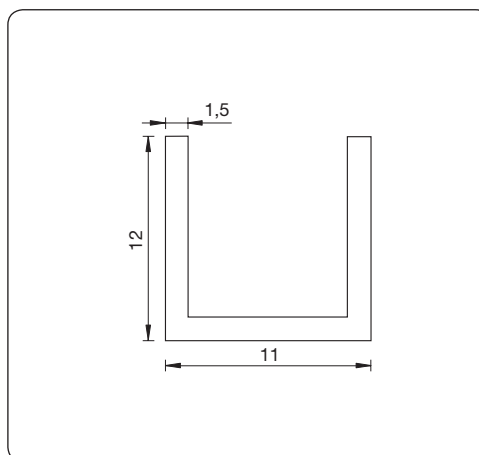
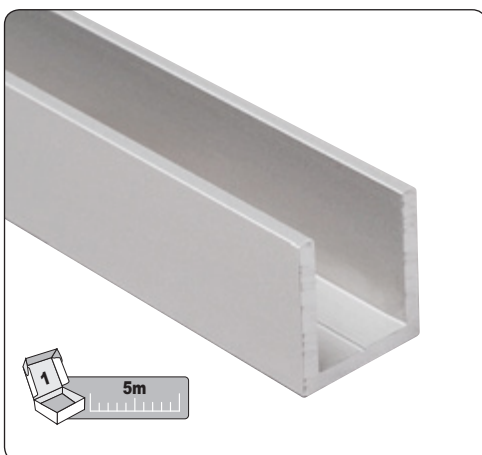

Art. Nr.: 5012

U-Profil 12 x 11 x 5000 x 1,5 mm

Plattendicke  ≤ 8 mm
Wichtig: + Toleranz nicht möglich

Material/Oberfläche: E = Aluminium



E6/EV1

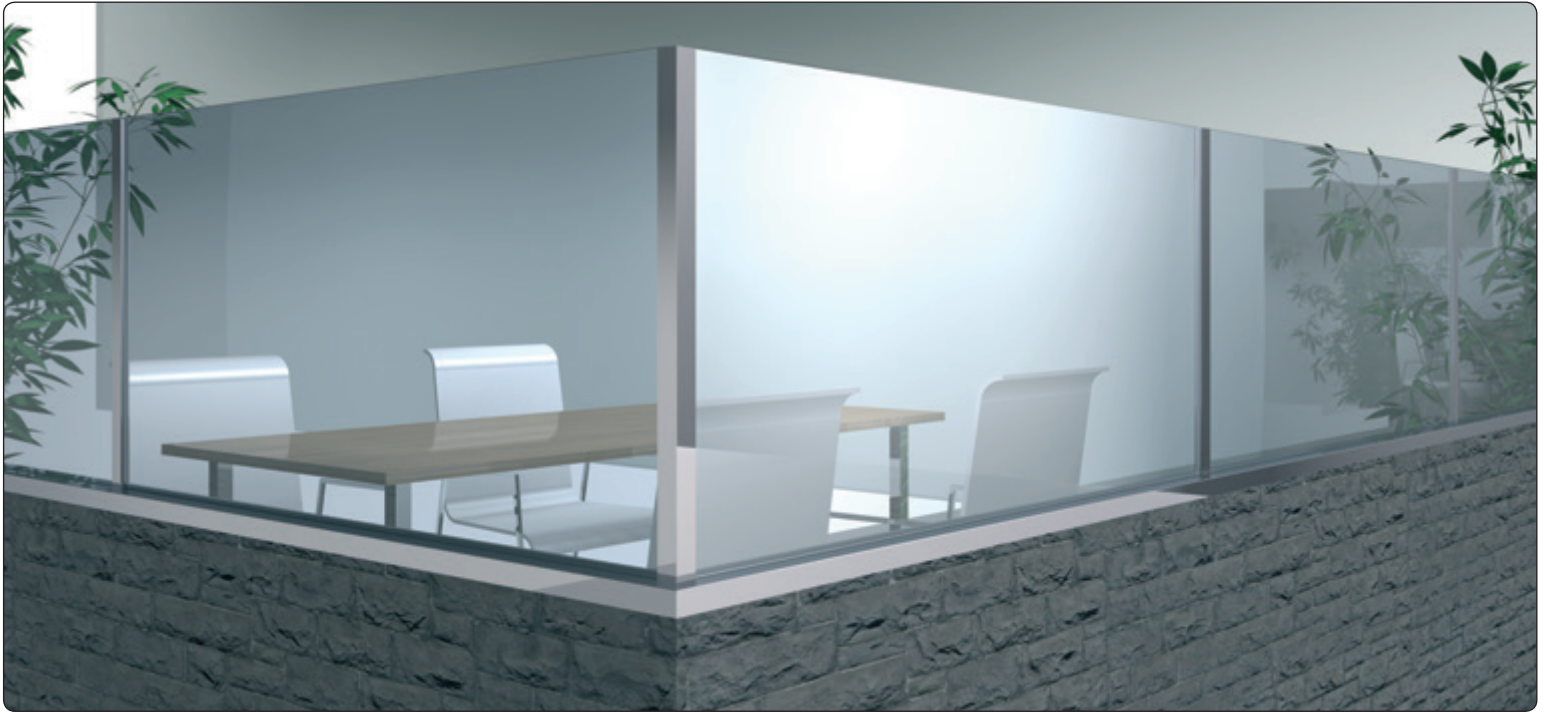
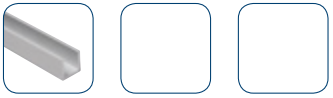



U-Profil

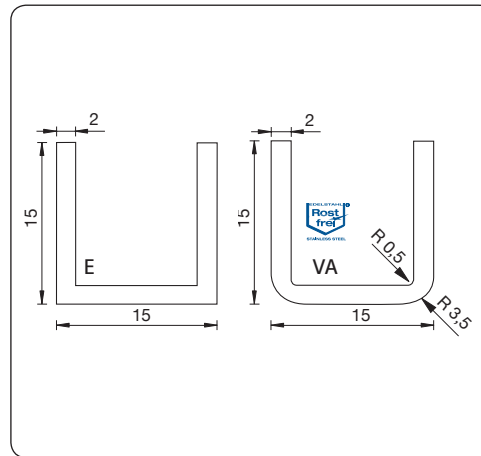
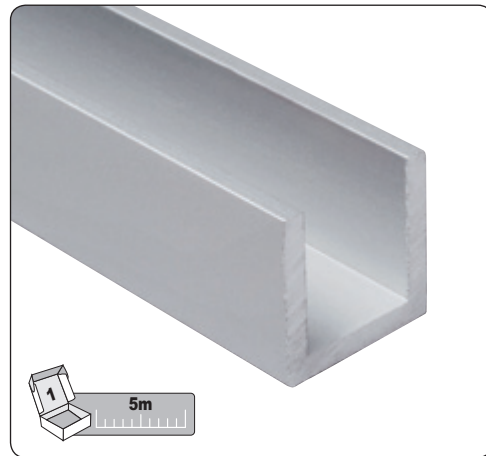

Art. Nr.: 5015

U-Profil 15 x 15 x 5000 x 2 mm

Plattendicke  ≤ 11 mm

Material/Oberfläche: E = Aluminium



E6/EV1 E6/EV5 E1/22 E3/50 E0/14

Material/Oberfläche VA = Edelstahl



VA1 VA2

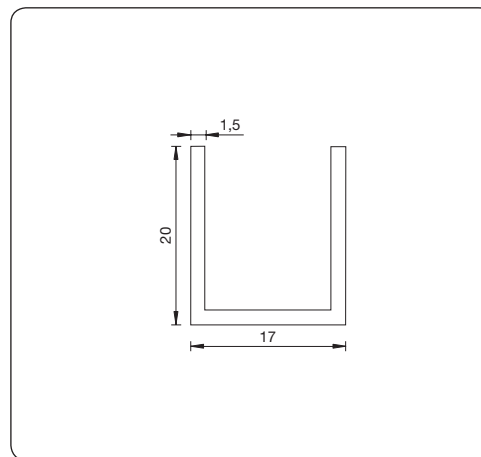
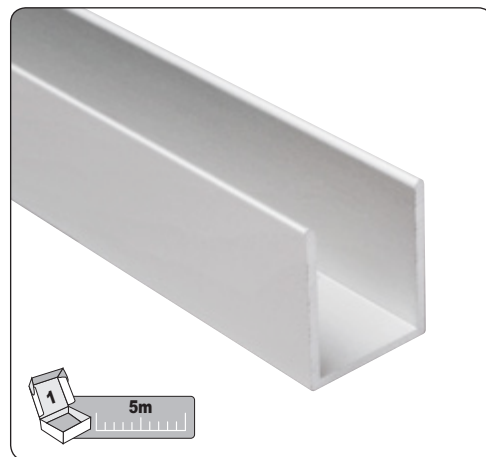

Art. Nr.: 5017

U-Profil 20 x 17 x 5000 x 1,5 mm

Plattendicke  ≤ 14 mm

Material/Oberfläche: E = Aluminium



E6/EV1 E1/22 E0/14

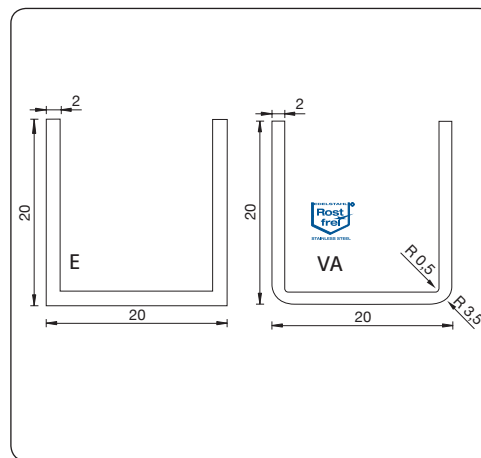

Art. Nr.: 5020

U-Profil 20 x 20 x 5000 x 2 mm

Plattendicke  ≤ 16 mm

Material/Oberfläche: E = Aluminium



E6/EV1 E1/22 E3/50 E0/14

Material/Oberfläche VA = Edelstahl



VA1 VA2

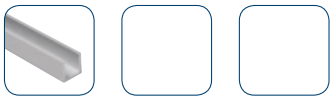

U-Profile

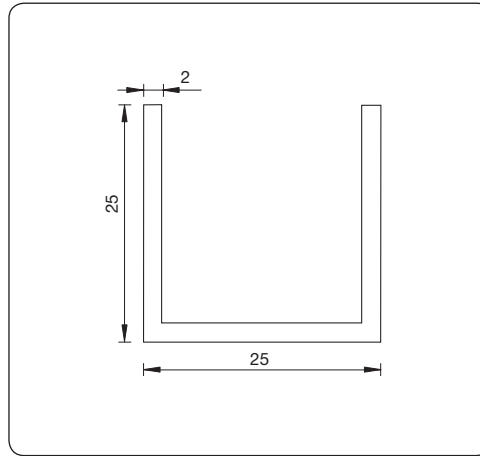
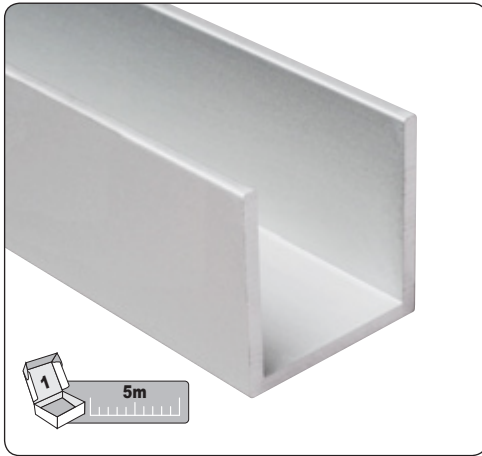

Art. Nr.: 5025

U-Profil 25 x 25 x 5000 x 2 mm

Plattendicke  ≤ 21 mm

Material/Oberfläche: E = Aluminium



E6/EV1



E1/22



E0/14

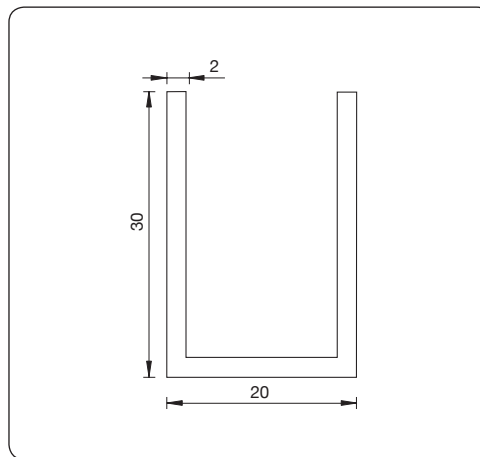
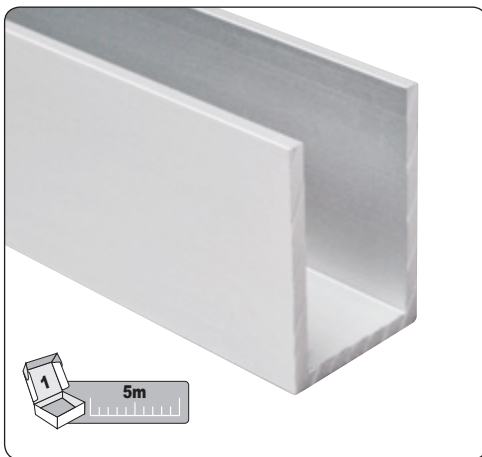

Art. Nr.: 5030

U-Profil 30 x 20 x 5000 x 2 mm

Plattendicke  ≤ 16 mm

Material/Oberfläche: E = Aluminium



E6/EV1



E1/22



E3/50



E0/14

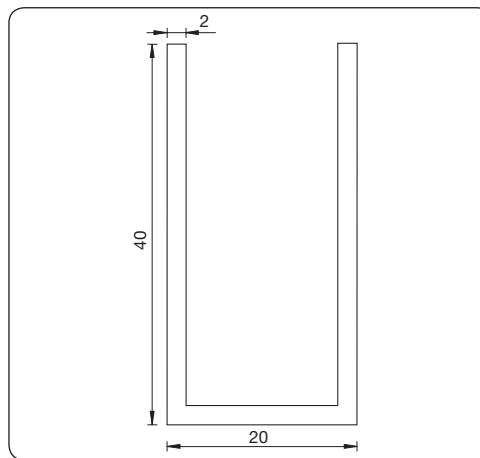
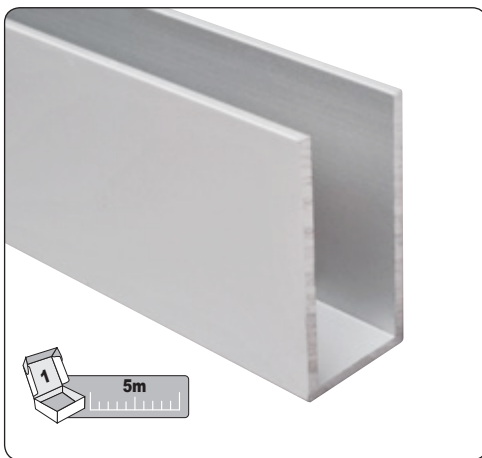

Art. Nr.: 5040

U-Profil 40 x 20 x 5000 x 2 mm

Plattendicke  ≤ 16 mm

Material/Oberfläche: E = Aluminium



E6/EV1



E1/22



E0/14



Winkelprofile

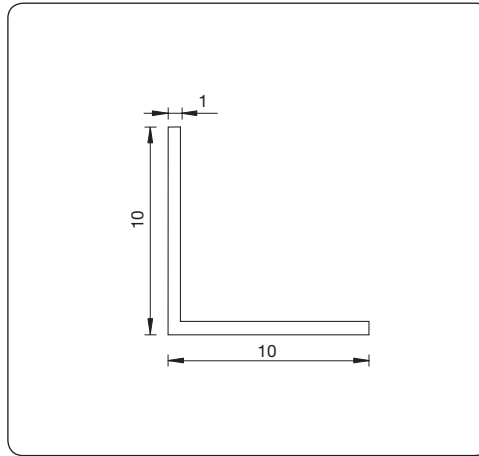
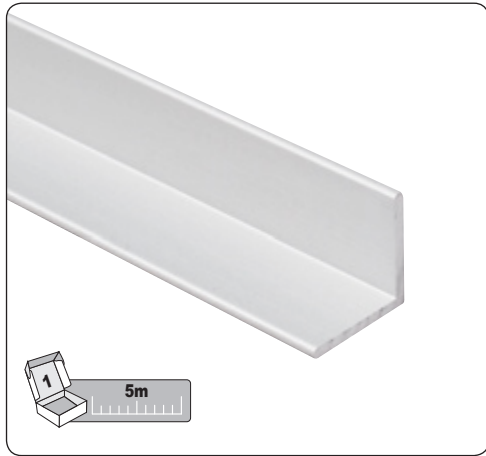

Art. Nr.: 5110

Winkelprofil 10 x 10 x 5000 x 1 mm

Material/Oberfläche: E = Aluminium



E6/EV1



E1/22

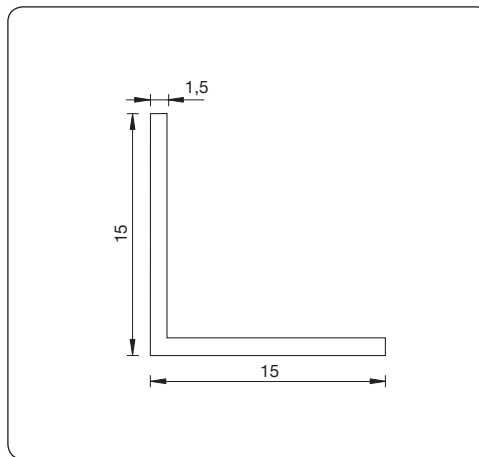
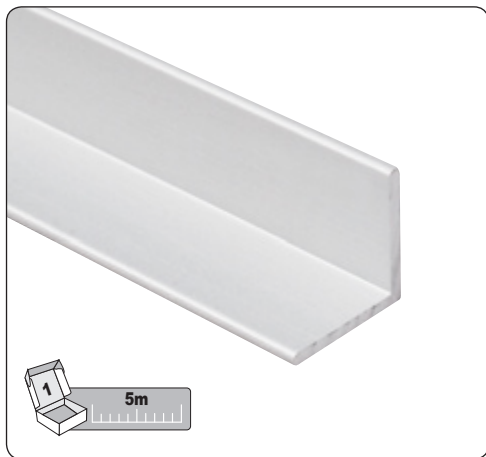

Art. Nr.: 5115

Winkelprofil 15 x 15 x 5000 x 1,5 mm

Material/Oberfläche: E = Aluminium



E6/EV1



E1/22

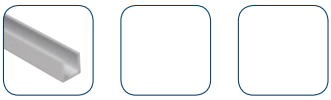

Winkelprofile

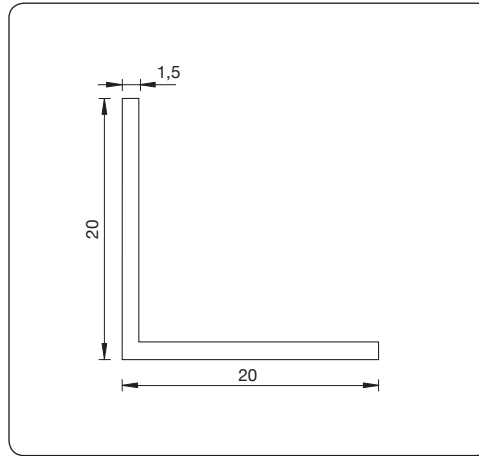
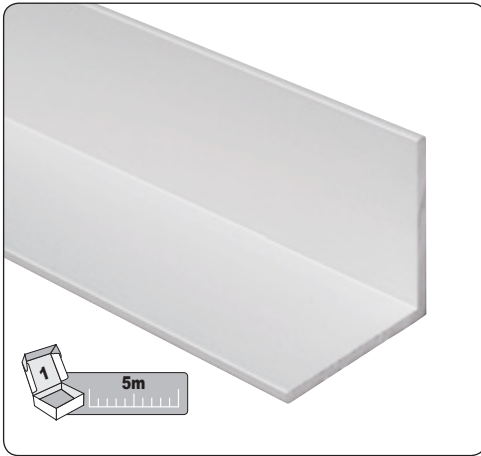

Art. Nr.: 5120

Winkelprofil 20 x 20 x 5000 x 1,5 mm

Material/Oberfläche: E = Aluminium



E6/EV1



E1/22

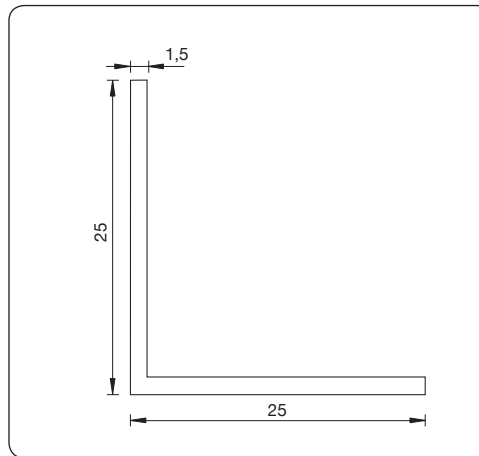
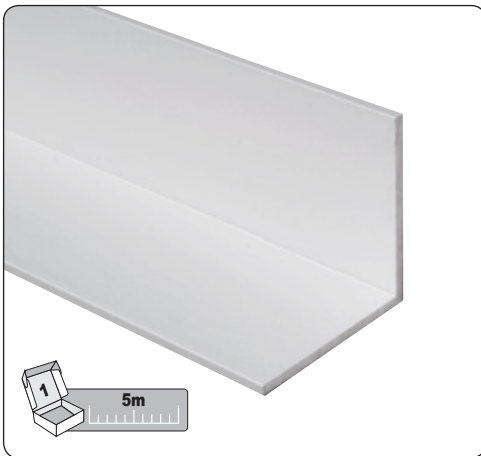

Art. Nr.: 5125

Winkelprofil 25 x 25 x 5000 x 1,5 mm

Material/Oberfläche: E = Aluminium



E6/EV1



E1/22



■ Mittelprofil

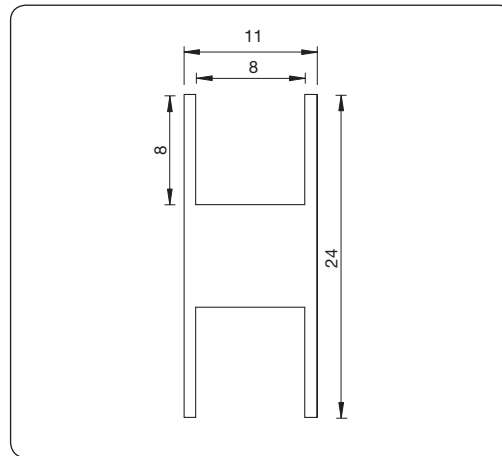

Art. Nr.: 5202

Mittelprofil 24 x 11 x 5000 x 1,5 mm

Plattendicke  ≤ 8 mm
Wichtig: + Toleranz nicht möglich

Material/Oberfläche: E = Aluminium



E6/EV1

■ Endprofil

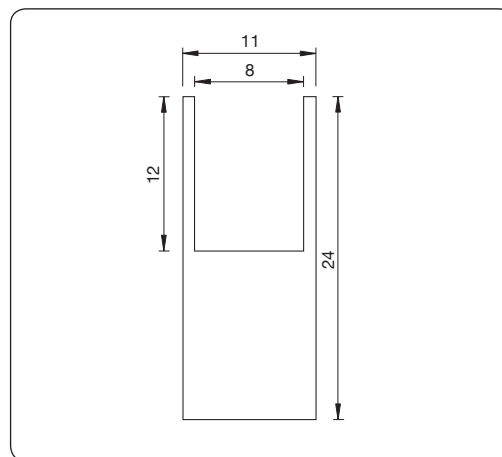
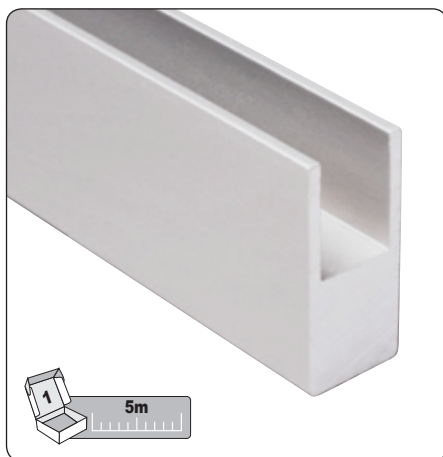

Art. Nr.: 5200

Endprofil 24 x 11 x 5000 x 1,5 mm

Plattendicke  ≤ 8 mm
Wichtig: + Toleranz nicht möglich

Material/Oberfläche: E = Aluminium



E6/EV1



■ Eckprofil

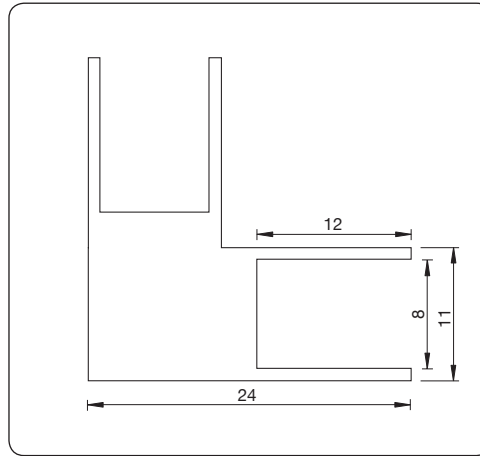
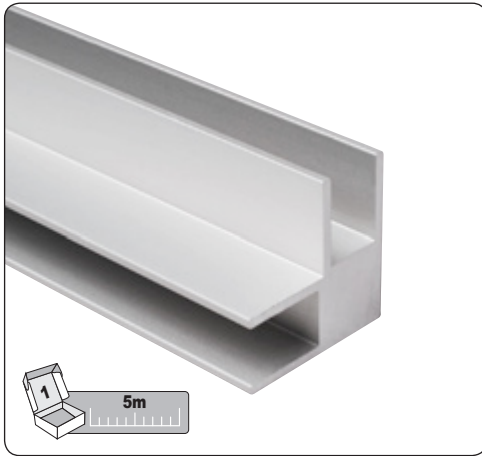

Art. Nr.: 5201

Eckprofil 24 x 11 x 5000 x 1,5 mm

Plattendicke  ≤ 8 mm
Wichtig: + Toleranz nicht möglich

Material/Oberfläche: E = Aluminium



E6/EV1

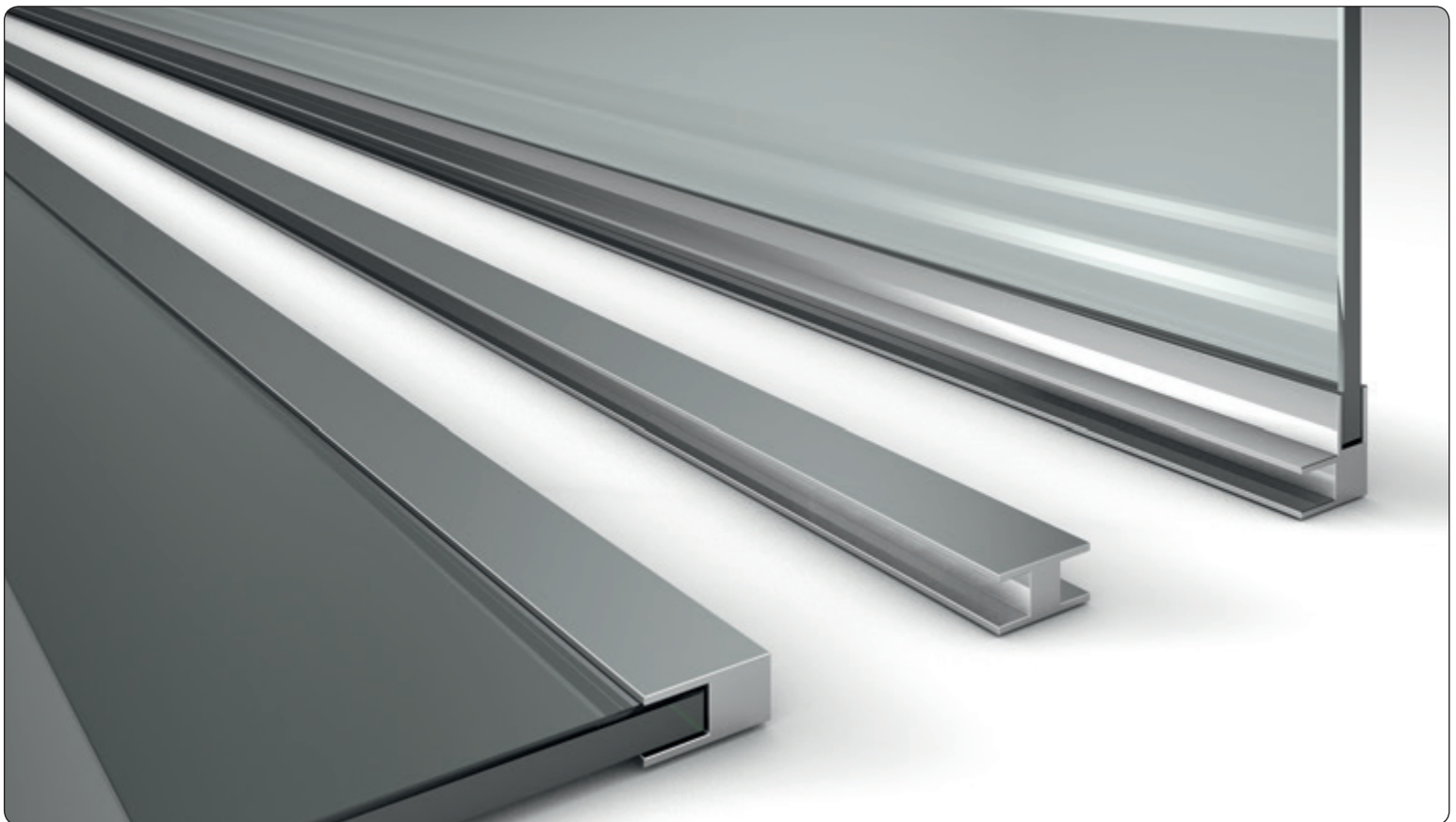



Spiegelprofile

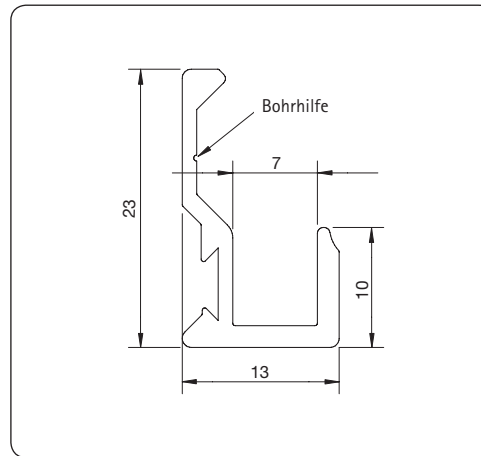

Art. Nr.: 2978

Spiegelprofil

Plattendicke

Wichtig: + Toleranz nicht möglich

 < 7 mm

Material/Oberfläche:

E = Aluminium



E6/EV1

Art. Nr.: 2979KU_-R, 2979KU_-L

Endstück zur Steckmontage,
rechte (-R) oder linke (-L) Ausführung,
passend zu 2978

Material/Oberfläche:

KU = Kunststoff



KU6

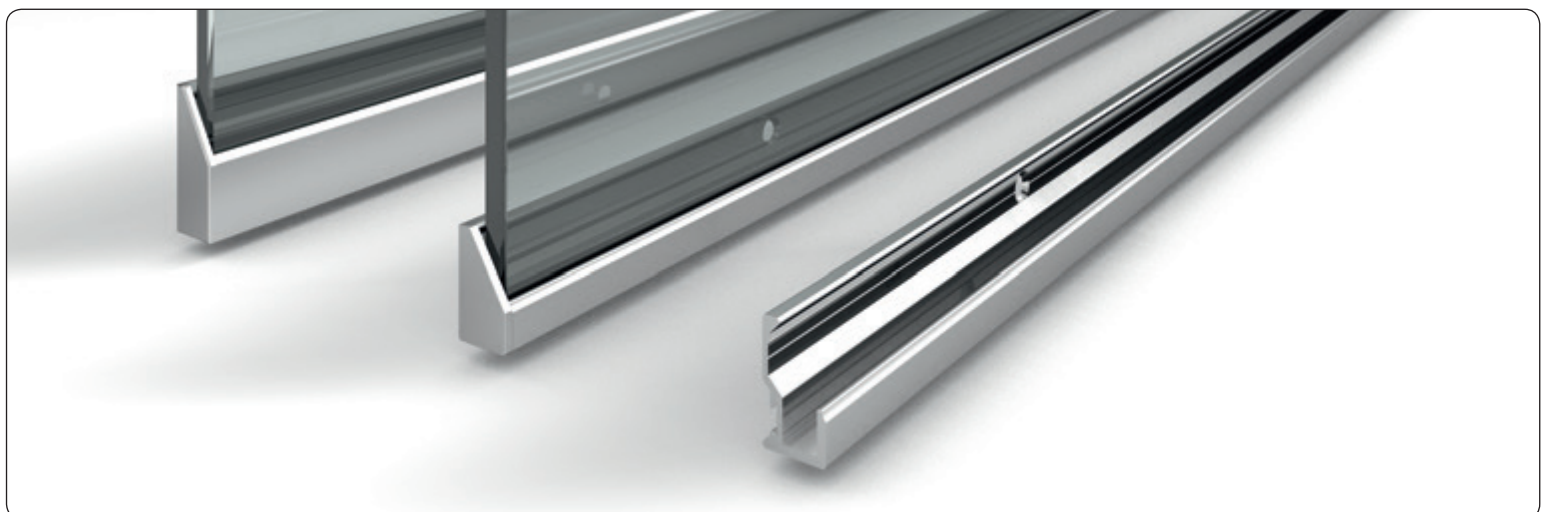
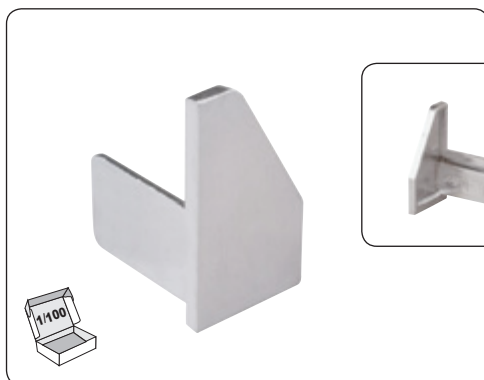

Anwendung Spiegelprofil

■ Spiegelprofile

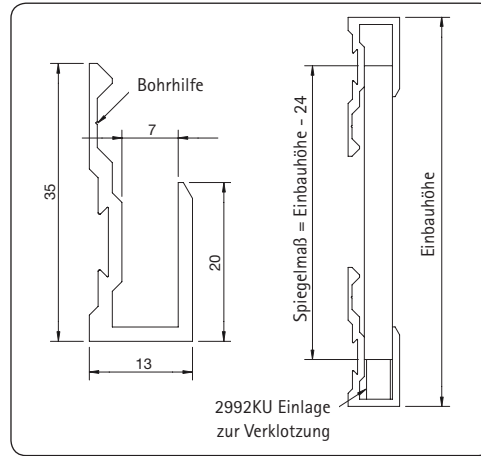

Art. Nr.: 2990

Spiegelprofil
Spiegelmaß = Einbauhöhe - 24 mm

Plattendicke  < 7 mm
Wichtig: + Toleranz nicht möglich

Material/Oberfläche: E = Aluminium

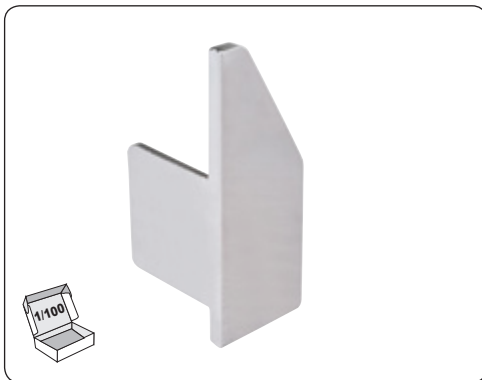

Art. Nr.: 2991KU_-R, 2991KU_-L

Endstück zur Steckmontage,
rechte (-R) oder linke (-L) Ausführung,
passend zu 2990

Material/Oberfläche: KU = Kunststoff



■ Einlage zur Verklotzung

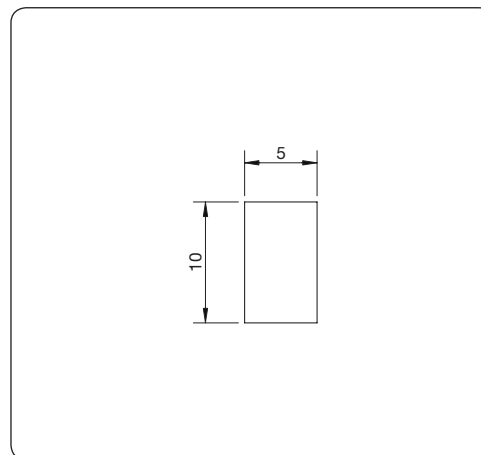
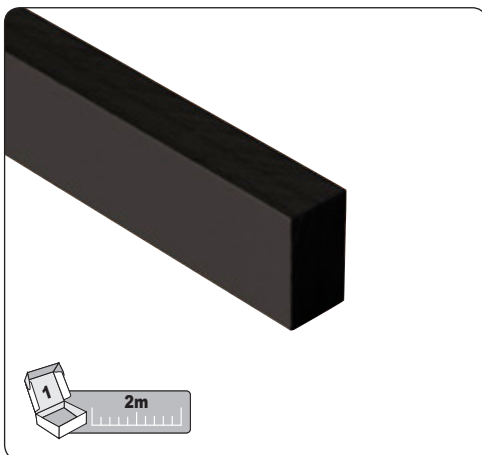

Art. Nr.: 2992

Einlage zur Verklotzung, passend zu 2990

Material/Oberfläche: KU = Kunststoff

Profile und
Trennwände



■ Klemmprofil

Profile und
Trennwände

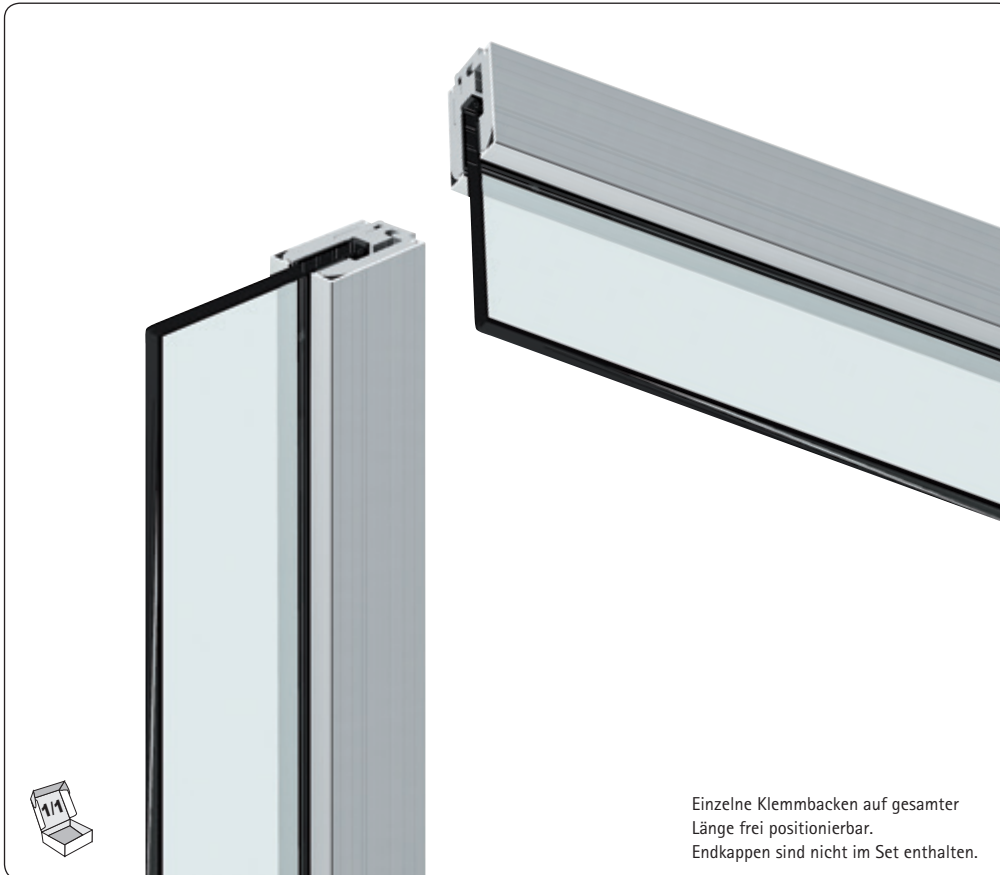

Einzelne Klemmbacken auf gesamter
Länge frei positionierbar.
Endkappen sind nicht im Set enthalten.

Art. Nr.: 8884-2010-8, 8884-2500-8

Klemmprofil

2010 mm = 5 Klemmbacken
2500 mm = 6 Klemmbacken

Plattendicke  8 mm

Material/Oberfläche: E = Aluminium



E6/EV5

Art. Nr.: 8884-2010, 8884-2500

Klemmprofil

2010 mm = 5 Klemmbacken
2500 mm = 6 Klemmbacken

Plattendicke  6 | 8 | 10 mm

Material/Oberfläche: E = Aluminium



E6/EV1



E6/EV5



E1/23



Art. Nr.: 8884-5000

Klemmprofil - 5000 mm = 12 Klemmbacken

Plattendicke  6 | 8 | 10 mm

Material/Oberfläche: E = Aluminium



E6/EV1



E1/22





■ Klemprofil

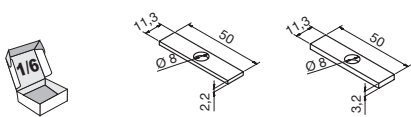

8885 Zwischenlage zum Ausgleich von Unebenheiten in der Wand: Durch Kombination und/oder Verdopplung können Unebenheiten ab 2 mm in 1 mm-Schritten ausgeglichen werden.

■ Endkappen für Klemprofil

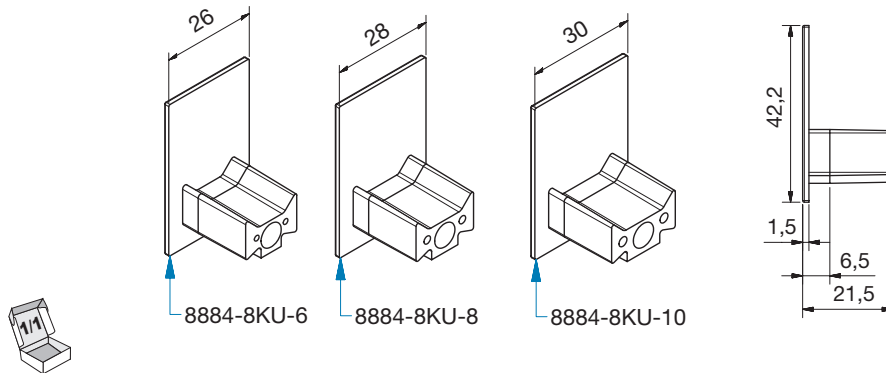

Art. Nr.: 8885HZ

Zwischenlage zu 8884

Material:

Hartzell

Art. Nr.: 8884-8

Endkappen für Klemprofil 8884, geschlossen

Plattendicke  6 | 8 | 10 mm

8884-8KU_-6 für 6 mm

8884-8KU_-8 für 8 mm

8884-8KU_-10 für 10 mm

Material/Oberfläche:

KU = Kunststoff



KU6



KU7



KU22

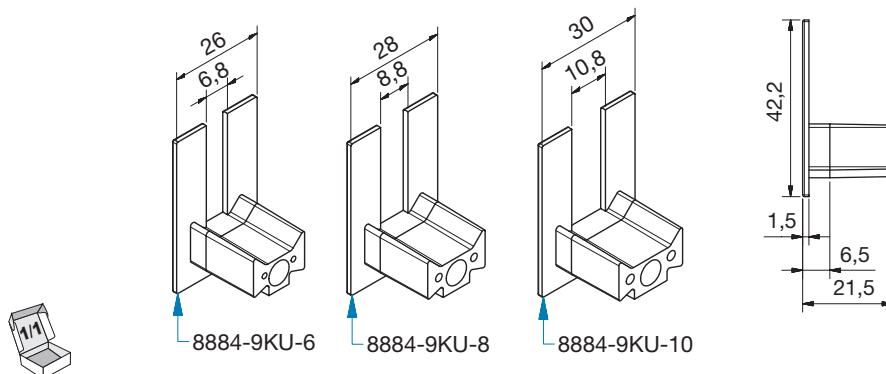

Art. Nr.: 8884-9

Endkappen für Klemprofil 8884, ausgeklinkt

Plattendicke  6 | 8 | 10 mm

8884-9KU_-6 für 6 mm

8884-9KU_-8 für 8 mm

8884-9KU_-10 für 10 mm

Material/Oberfläche:

KU = Kunststoff



KU6



KU7



KU22



8884-8



8884-9



■ Klemmprofil - Anwendung für vertikale Befestigung

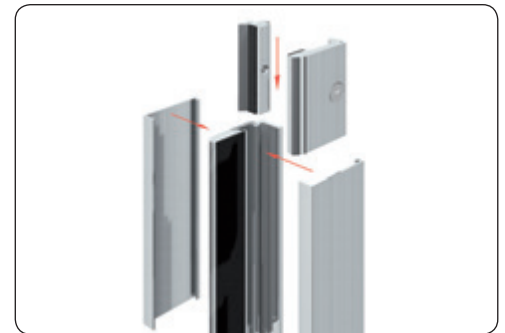
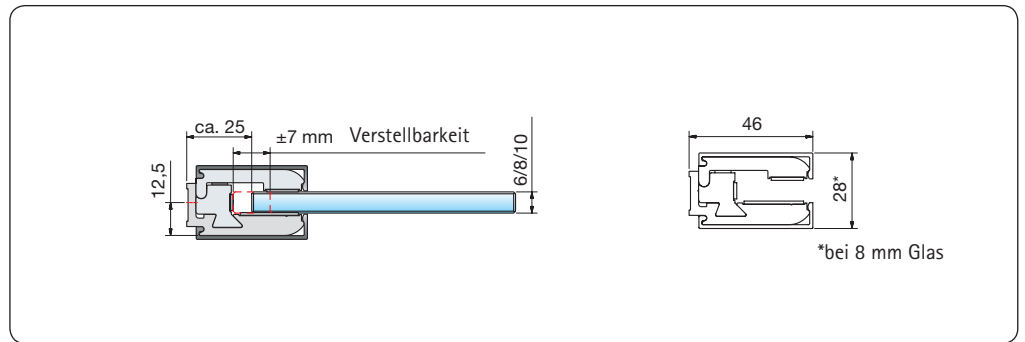



■ Klemprofil - Anwendung für Oberlicht

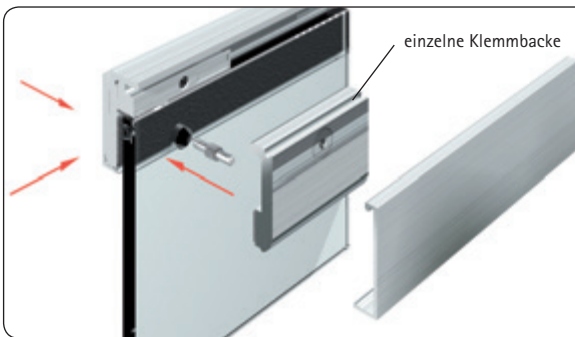
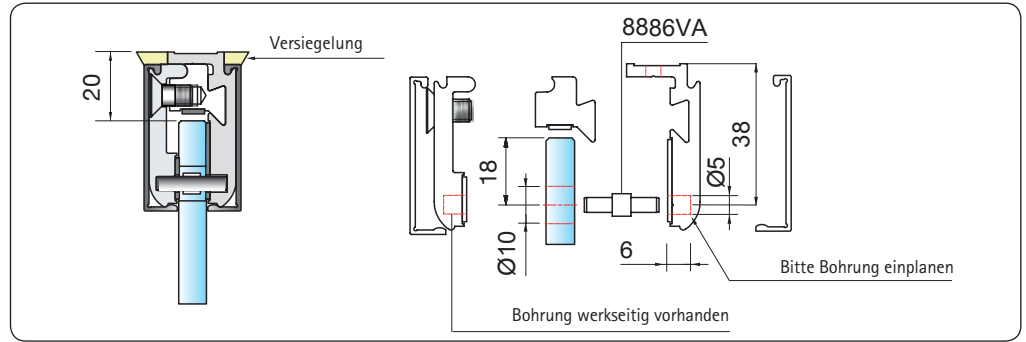

Zubehör: Art. Nr.: 8886 Sicherungsstift

Für Anwendung als
Deckenabhängung
pro Klembacke
ein Sicherungsstift

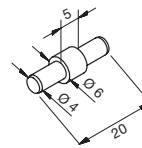

Glasbearbeitung

mit Entlastungsschnitt

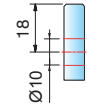
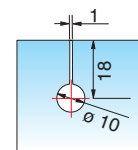

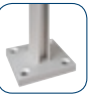

Trennwandstützen und Bodenhalter



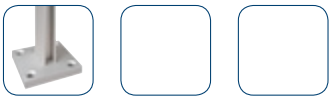

Trennwand-Mittelstütze

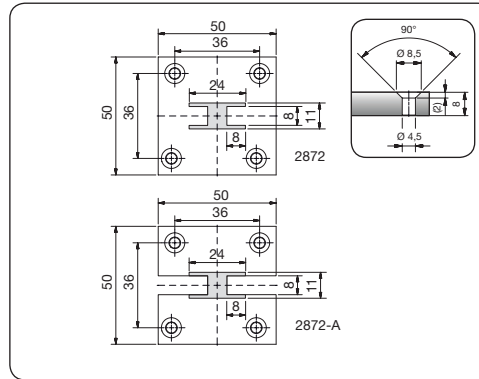
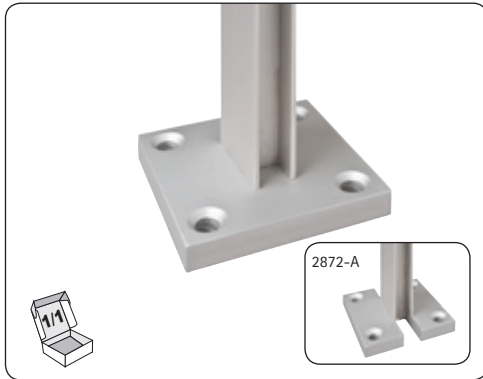

Art. Nr.: 2872 | 2872-A

Trennwand-Mittelstütze

Höhe 150 - 1000 mm, jeweils um 50 mm steigend

Plattendicke  ≤ 8 mm

Wichtig: + Toleranz nicht möglich

Material/Oberfläche: E = Aluminium

2872

2872-A mit Ausklinkung



E6/EV1

Trennwand-Endstütze

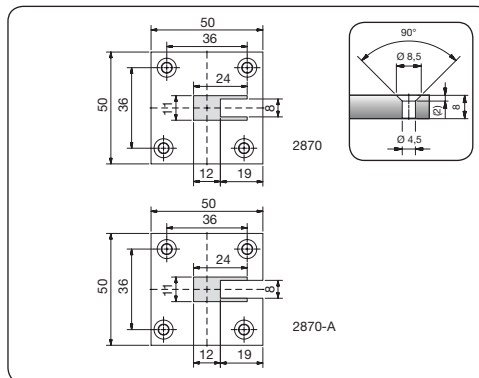
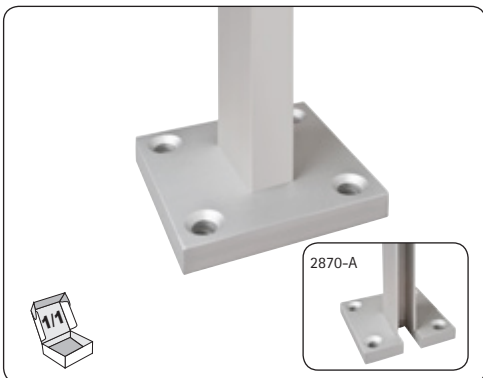

Art. Nr.: 2870 | 2870-A

Trennwand-Endstütze

Höhe 150 - 1000 mm, jeweils um 50 mm steigend

Plattendicke  ≤ 8 mm

Wichtig: + Toleranz nicht möglich

Material/Oberfläche: E = Aluminium

2870

2870-A mit Ausklinkung



E6/EV1

Trennwand-Eckstütze

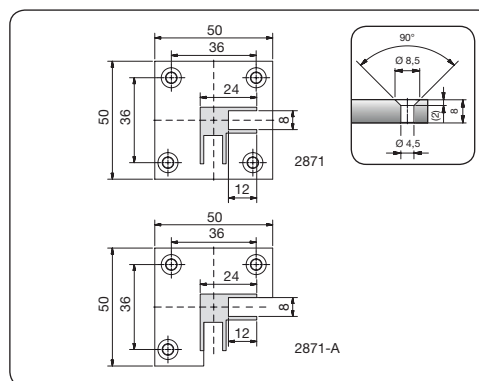
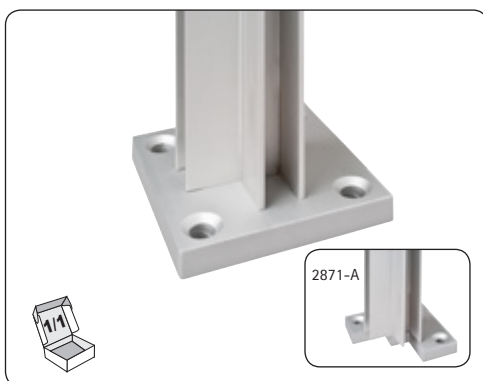

Art. Nr.: 2871 | 2871-A

Trennwand-Eckstütze

Höhe 150 - 1000 mm, jeweils um 50 mm steigend

Plattendicke  ≤ 8 mm

Wichtig: + Toleranz nicht möglich

Material/Oberfläche: E = Aluminium

2871

2871-A mit Ausklinkung



E6/EV1

Bei Bestellung bitte die Länge angeben!



Winkelverbinder



Profile und
Trennwände



Winkelverbinder, flächenbündig

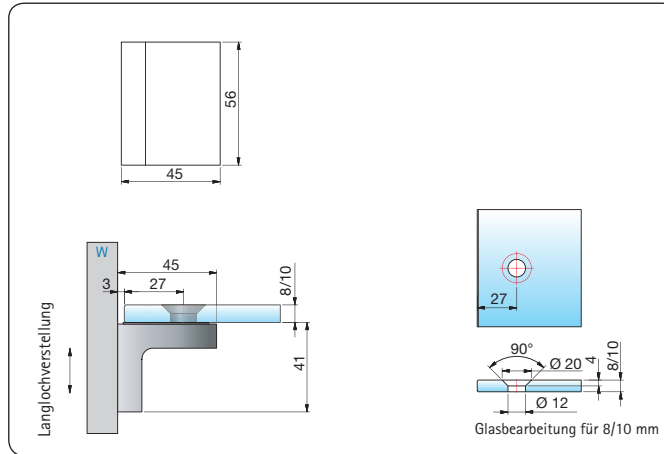
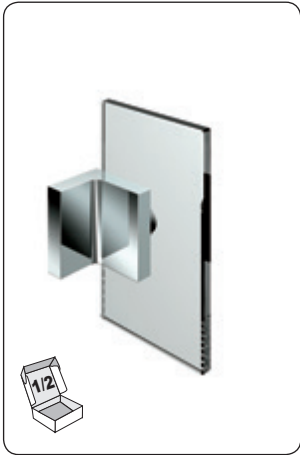

Art. Nr.: 8380

Winkelverbinder, Glas-Wand 90°,

flächenbündig, Lasche außen mit Langlochverstellung, mit Abdeckkappe, Punkthalter ± 2 mm in jede Richtung verstellbar

Plattendicke  8/10 mm

Material/Oberfläche ZN = Zink

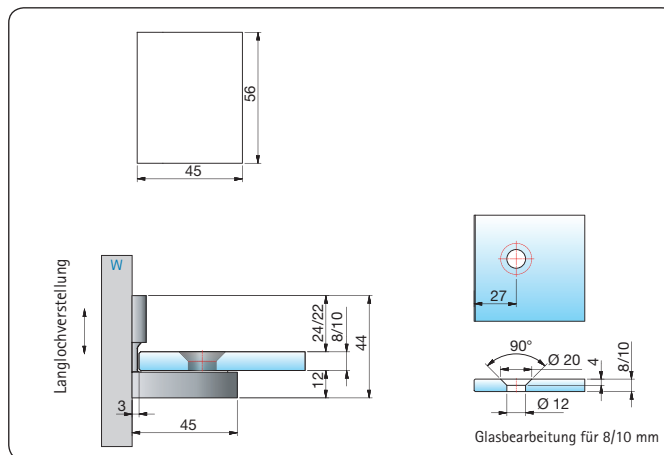
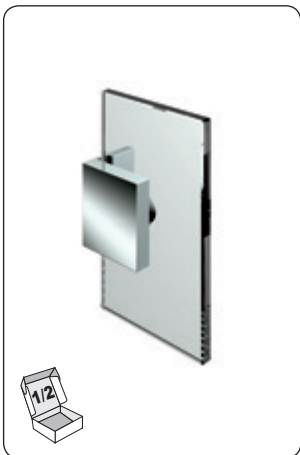

Art. Nr.: 8381

Winkelverbinder, Glas-Wand 90°,

flächenbündig, Lasche innen mit Langlochverstellung, mit Abdeckkappe, Punkthalter ± 2 mm in jede Richtung verstellbar

Plattendicke  8/10 mm

Material/Oberfläche ZN = Zink

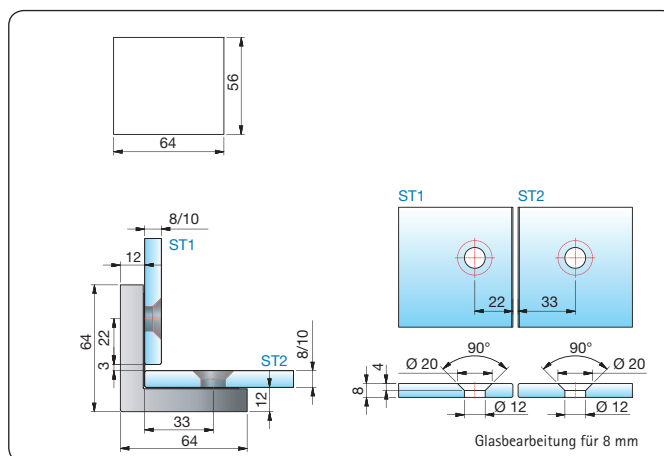
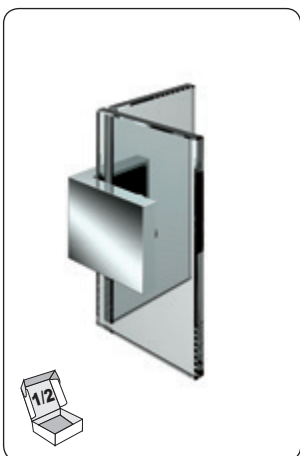

Art. Nr.: 8382

Winkelverbinder, Glas-Glas 90°,

flächenbündig, mit Abdeckkappe, Punkthalter ± 2 mm in jede Richtung verstellbar

Plattendicke  8/10 mm

Material/Oberfläche ZN = Zink



ST = Seitenteil

W = Wand



Winkelverbinder mit Gegenplatte

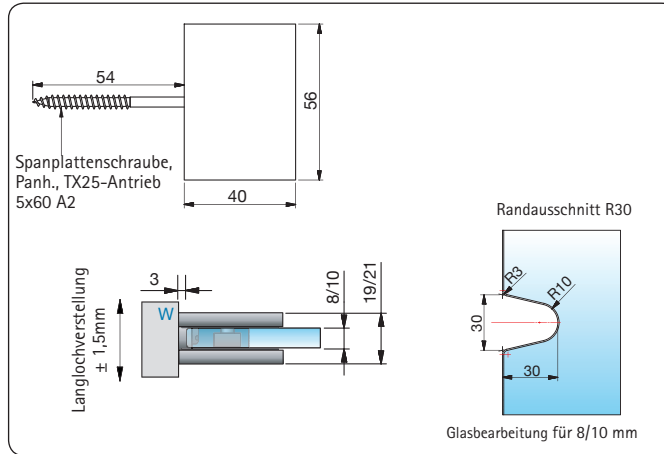
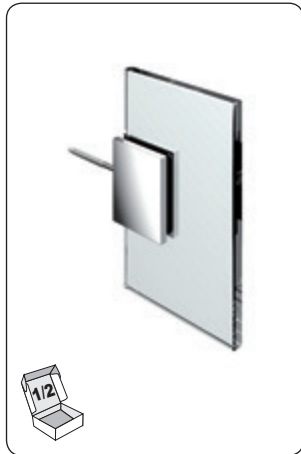

Art. Nr.: 8178

Winkelverbinder, Glas-Wand 90°

Wandbefestigung mit Langlochverstellung, ohne sichtbare Befestigungsglasche, inkl. Schraube

Plattendicke  8/10 mm

Material/Oberfläche ZN = Zink



ST = Seitenteil

W = Wand

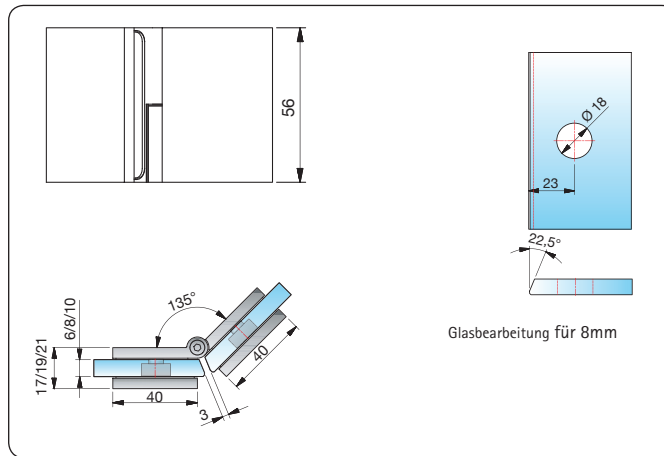

Art. Nr.: 8175

verstellbarer Winkelverbinder, Glas-Glas 135°

Winkelgradzahl stufenlos von 80°-180° verstellbar

Plattendicke  6/8/10 mm

Material/Oberfläche ZN = Zink



Informationen

Weitere Winkelverbinder finden Sie in unseren Duschenwelten 2014.

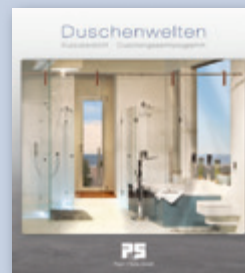



■ Anwendung





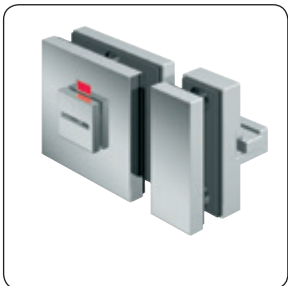
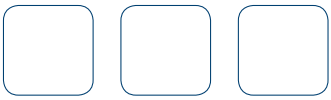

■ Toiletten-/Umkleidekabinen



Flamea+ – kompromisslose Technik mit höherer Tragkraft

Die neue Serie Flamea+ bietet Ihnen ein Beschlagprogramm mit komplett verdeckter Verschraubung und erhöhter Tragkraft. Die stufenlos einstellbare Nulllage sorgt für eine perfekte Anpassung an unterschiedlichste Einbausituationen.

- beidseitig 90° öffnendes Pendeltürband
- auf den letzten Zentimetern selbstschließend
- Pendeltürband - mittig liegender Drehpunkt
- stufenlose Nulllageneinstellung
- Tragfähigkeit (2 Bänder): 45 kg
entsprechen einer maximalen Türflügelgröße von
900 x 2000 mm bei 10 mm Glasdicke
- keine sichtbare Verschraubung
- minimierte Spaltmaße



Die richtige Montage

Pendeltürband oder Anschlagtürband - die richtige Montage hat entscheidenden Einfluss auf Funktion und Langlebigkeit. Bitte beachten Sie die bei den Türbändern beigelegte Montageanleitung und übergeben Sie diese nach der Montage Ihrem Kunden.

Wichtige Hinweise finden Sie in unserem aktuellen Katalog Duschenwelten. Unsere technischen Kataloge stehen unter www.pauli.de zum Download zur Verfügung.

Bitte beachten Sie: Bedingung für die Gewährleistung bzw. Garantie ist der Einbau gemäß Montageanleitung.



Verbauungsorte und Pflegehinweis

Die Beschläge dürfen nicht in Räumen mit hohem Chlor- und Alkaligehalt eingesetzt werden - dadurch werden die Oberflächen und die Mechanik nachhaltig geschädigt. Bei Anwendungen mit unseren Türbändern im Schwimmbad- und Saunabereich oder im Bereich von Solebecken und Dampfsaunen bitten wir Sie, unsere Anwendungstechnik vor der Verbauung zu kontaktieren.

Die Bänder dürfen nur mit warmen Wasser

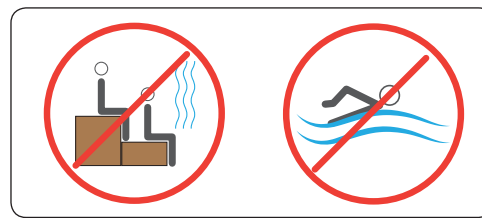

und einem weichen Tuch (z.B. Mikrofaser) feucht abgewischt und gegebenenfalls nachgetrocknet werden. Scharfe, aggressive, alkalische oder chlorhaltige Reiniger,

Scheuermittel (z.B. Stahlwolle) oder Lösungsmittel sollten nicht verwendet werden.

Für die Verbauung im Saunabereich bieten wir Ihnen die neue Serie Flamea+-SN an. Bitte wenden Sie sich auch hier an unsere Anwendungstechnik.



Glas und Beschläge vor Fehlbedienung schützen

Um Türbänder und Glas vor Beschädigungen zu schützen, ist bei der Planung der Bausituation zu berücksichtigen, dass die Türflügel nicht überdrückt werden dürfen (max. 90°). Für Abhilfe sorgt z.B. ein an der richtigen Stelle positionierter Stopper. Wir bieten verschiedene Möglichkeiten des Überdrückungsschutzes an.

Hier haben wir für Sie ein paar Beispiele aufgelistet. Weitere Produkte finden Sie im Katalog Duschenwelten 2014.

Sie brauchen Hilfe bei der Planung und Umsetzung? Gerne berät Sie unser technischer Vertrieb.



8273MS7



8490MS7-R

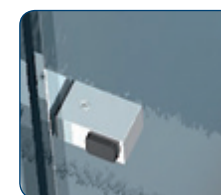

8274MS-D



8499MS7



■ Pendeltürbänder



Achtung: Je nach Belastung, Türgröße und Anforderung an die Steifigkeit, werden zusätzliche Aussteifungsartikel benötigt. Je nach Größe der Seitenteile ist die Anzahl der Bodenhalter anzupassen. Türen sind in ihrem Öffnungsweg zu begrenzen. Dazu ist ein Überdrückungs- und Anschlagschutz zu verwenden. Wir beraten Sie hierzu gerne.

Profile und
Trennwände

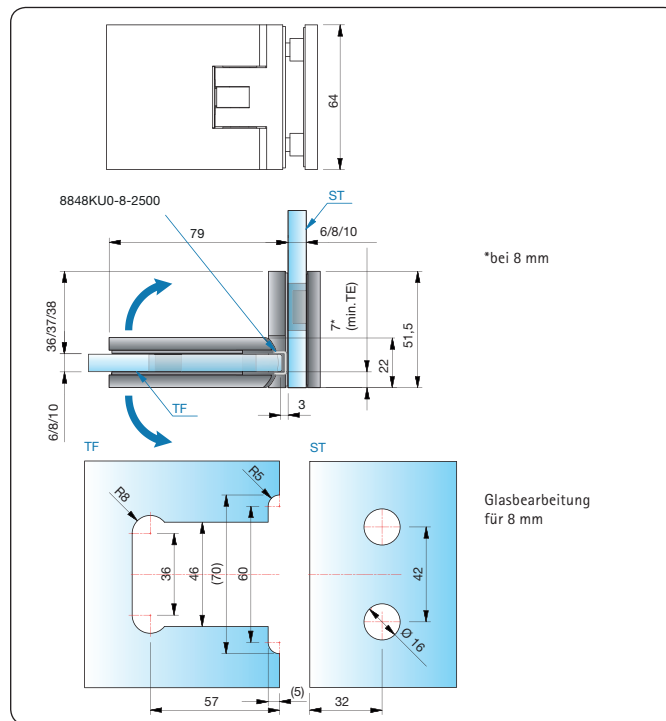

*bei 8 mm

Glasbearbeitung für 8 mm

ST = Seitenteil

TF = Türflügel

TE = Türeinstand

Art. Nr.: 8136

Pendeltürband, Glas-Glas 90°

beidseitig 90° öffnend,
mit verstellbarer Nulllagenstellung
verdeckte Verschraubung mit Abdeckkappe

Plattendicke  6/8/10 mm

Material/Oberfläche ZN = Zink



ZN1



ZN5



ZNPVD22





Achtung: Je nach Belastung, Türgröße und Anforderung an die Steifigkeit, werden zusätzliche Aussteifungsartikel benötigt. Je nach Größe der Seitenteile ist die Anzahl der Bodenhalter anzupassen. Türen sind in ihrem Öffnungsweg zu begrenzen. Dazu ist ein Überdrückungs- und Anschlagsschutz zu verwenden. Wir beraten Sie hierzu gerne.

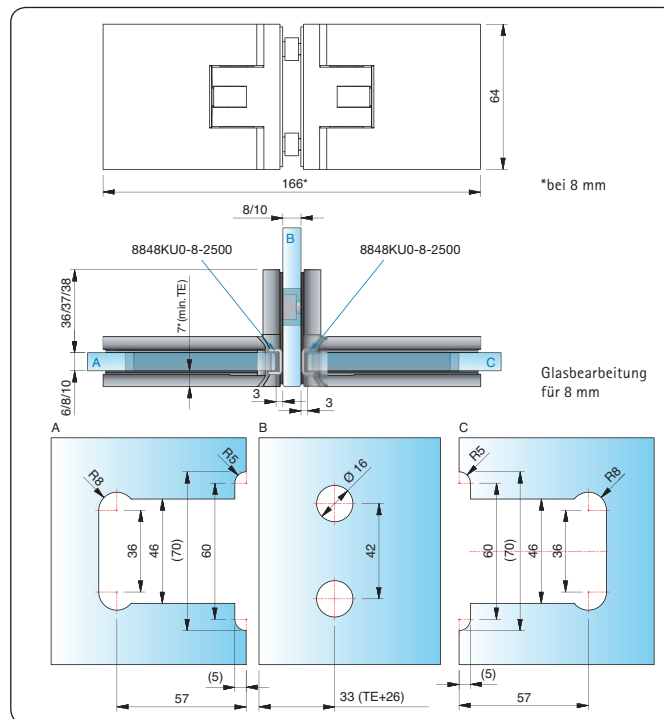

TE = Türeinstand

Art. Nr.: 8137

zweiseitiger Pendeltürbeschlag Glas-Glas-Glas 90°

beidseitig 90° öffnend, mit verstellbarer Nulllagenstellung, verdeckte Verschraubung mit Abdeckkappe

Plattendicke Trennwand  8/10 mm

Plattendicke Türen  6/8/10 mm

Material/Oberfläche ZN = Zink



ZN1



ZN5



ZNPVD22



■ Pendeltürbänder/ Winkelverbinder mit Gegenplatte



Profile und
Trennwände

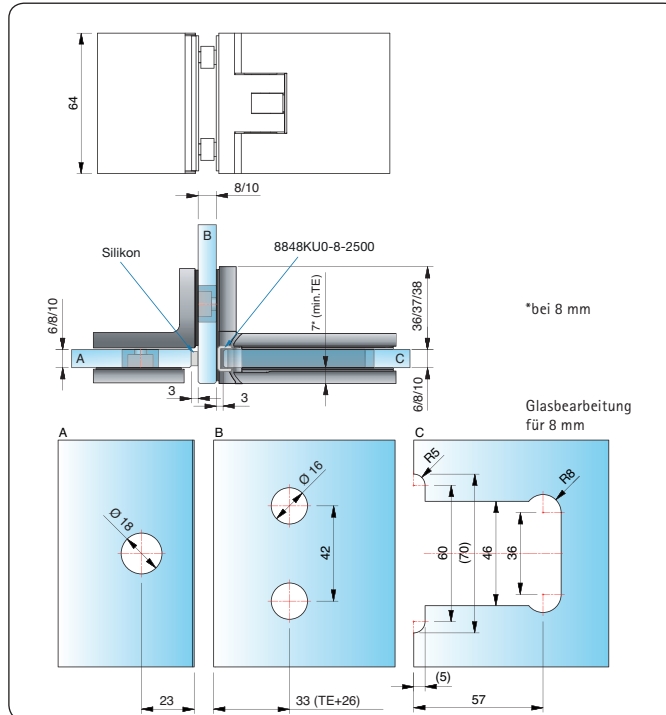

TE = Türeinstand

Art. Nr.: 8138

Winkel/Pendeltürbeschlag Glas-Glas-Glas 90°

Pendeltürbeschlag beidseitig 90° öffnend,
mit verstellbarer Nulllagenstellung
Winkelverbinder starr
verdeckte Verschraubung mit Abdeckkappe

Plattendicke Trennwand (B)  8/10 mm

Plattendicke Tür/Seitenteil (A/C)  6/8/10 mm

Material/Oberfläche ZN = Zink



ZN1



ZN5



ZNPVD22

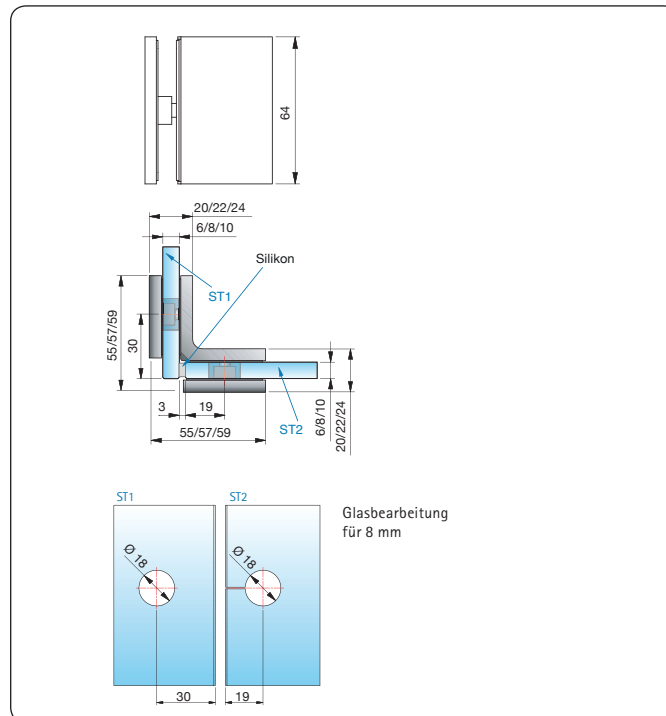

ST = Seitenteil

Art. Nr.: 8196

Winkelverbinder, Glas-Glas 90°

verdeckte Verschraubung mit Abdeckkappe

Plattendicke  6/8/10 mm

Material/Oberfläche ZN = Zink



ZN1



ZN5



ZNPVD22



Profile und
Trennwände

Achtung: Je nach Belastung, Türgröße und Anforderung an die Steifigkeit, werden zusätzliche Aussteifungsartikel benötigt. Je nach Größe der Seitenteile ist die Anzahl der Bodenhalter anzupassen. Türen sind in ihrem Öffnungsweg zu begrenzen. Dazu ist ein Überdrückungs- und Anschlagsschutz zu verwenden. Wir beraten Sie hierzu gerne.



Winkelverbinder mit Gegenplatte

Profile und
Trennwände

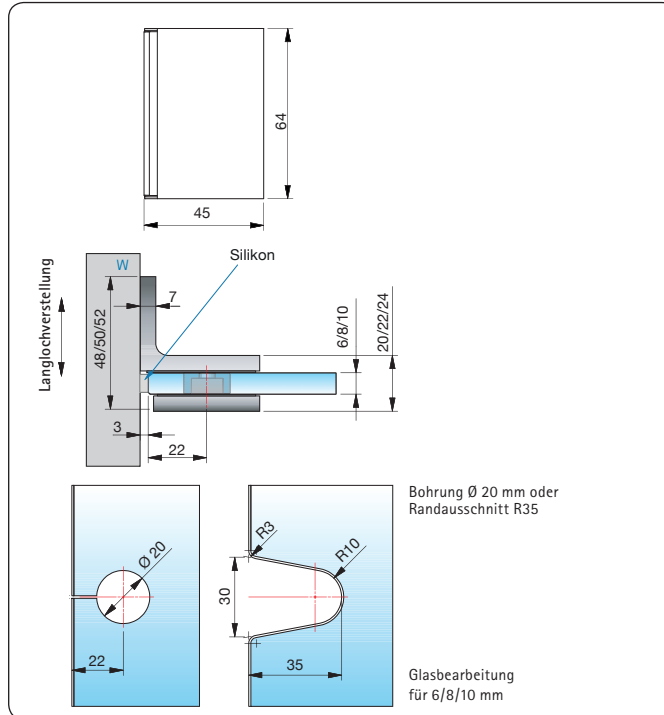

Art. Nr.: 8194

Winkelverbinder, Glas-Wand 90°

Wandbefestigung mit Langlochverstellung, verdeckte Verschraubung mit Abdeckkappe

Plattendicke  6/8/10 mm

Material/Oberfläche ZN = Zink



ZN1



ZN5



ZNPVD22

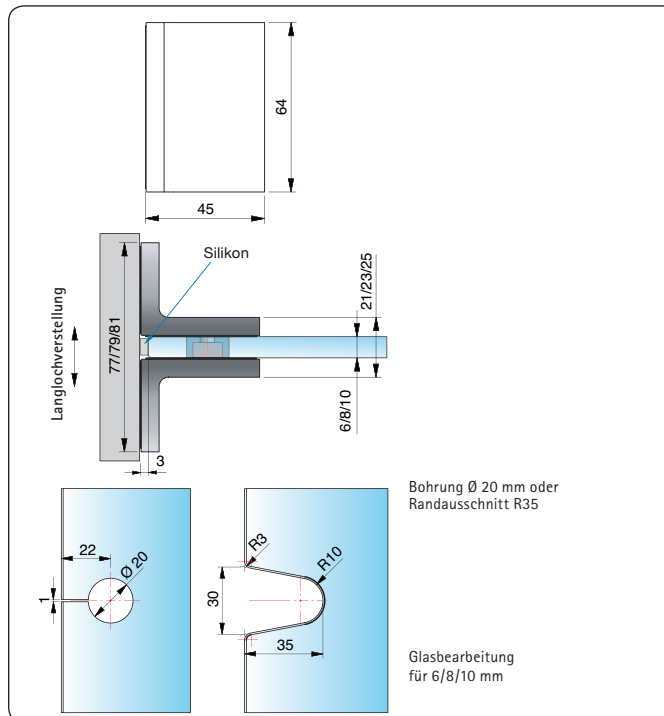
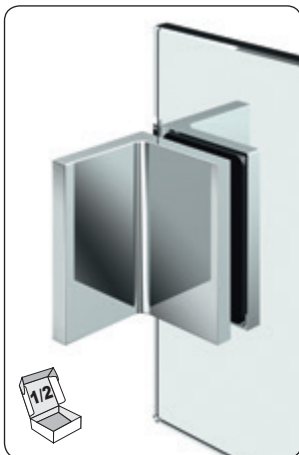

Art. Nr.: 8195

zweiseitiger Winkelverbinder Wand-Glas-Wand 90°

Wandbefestigung mit Langlochverstellung, beidseitige Befestigungsglasche verdeckte Verschraubung mit Abdeckkappe

Plattendicke  6/8/10 mm

Material/Oberfläche ZN = Zink



ZN1



ZN5



ZNPVD22





■ Pendeltürbänder/ Winkelverbinder mit Gegenplatte

Profile und
Trennwände

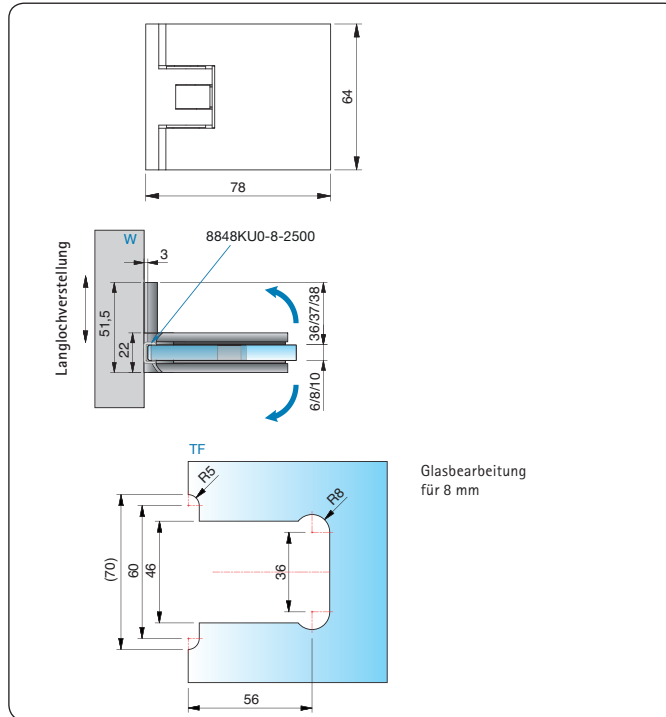

TF = Türflügel

Art. Nr.: 8130

Pendeltürbeschlag Glas-Wand 90°

beidseitig 90° öffnend, mit verstellbarer Nulllagenstellung, einseitige Befestigungslasche verdeckte Verschraubung mit Abdeckkappe

Plattendicke  6/8/10 mm

Material/Oberfläche ZN = Zink



ZN1



ZN5



ZNPVD22

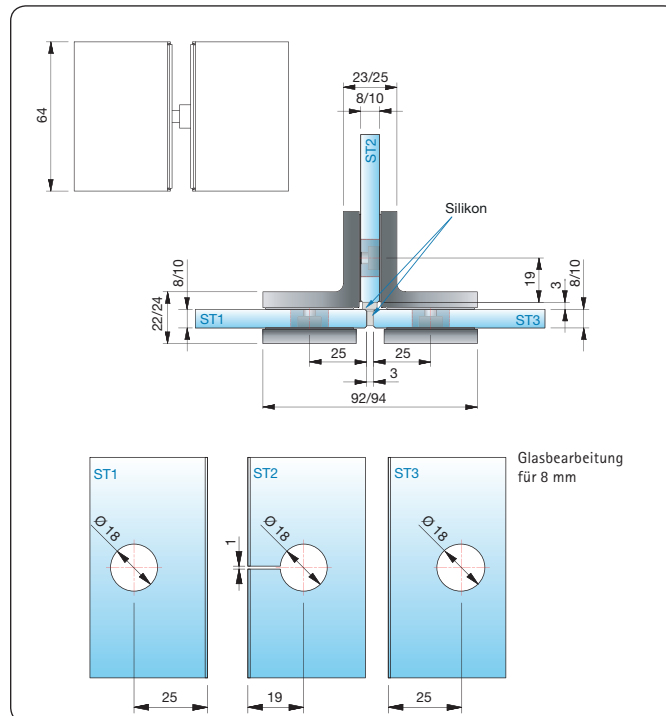

ST = Seitenteil

Art. Nr.: 8197

zweiseitiger Winkelverbinder, Glas-Glas-Glas 90°

verdeckte Verschraubung mit Abdeckkappe

Plattendicke  8/10 mm

Material/Oberfläche ZN = Zink



ZN1



ZN5



ZNPVD22



■ Anwendung



Profile und
Trennwände



Achtung: Je nach Belastung, Türgröße und Anforderung an die Steifigkeit, werden zusätzliche Aussteifungsartikel benötigt. Je nach Größe der Seitenteile ist die Anzahl der Bodenhalter anzupassen. Türen sind in ihrem Öffnungsweg zu begrenzen. Dazu ist ein Überdrückungs- und Anschlagsschutz zu verwenden. Wir beraten Sie hierzu gerne.



Stabilisierungsstangen

Glasdicke: 6-10 mm

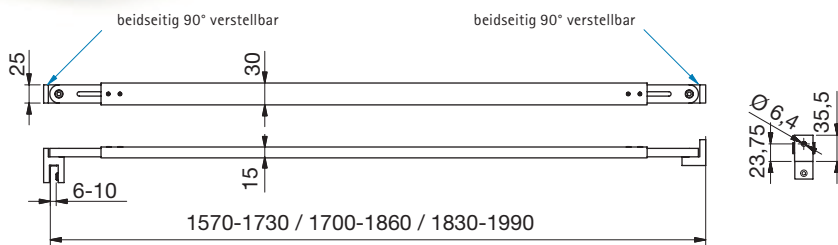

Glasdicke: 6-10 mm

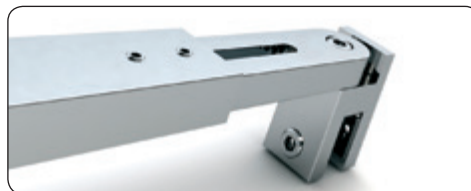
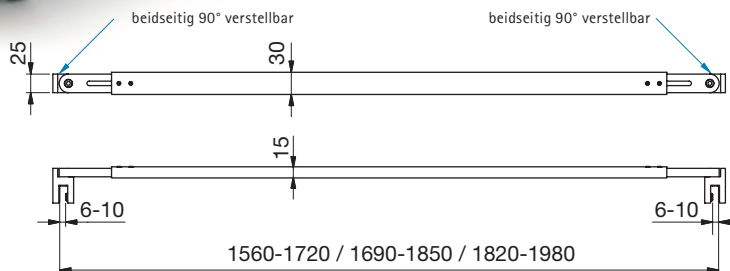

Art. Nr.: 8474

Stabilisierungsstange, Glas-Wand

Längen:

1650 mm - von 1570-1730 mm verstellbar

1780 mm - von 1700-1860 mm verstellbar

1910 mm - von 1830-1990 mm verstellbar

Material/Oberfläche

MS=Messing



MS7



MS10



MSPVD22

Weitere Längen finden Sie in unseren Duschenwelten 2013/14 auf Seite 180. Andere Längen auf Anfrage!

Art. Nr.: 8475

Stabilisierungsstange, Glas-Glas

Längen:

1640 mm - von 1560-1720 mm verstellbar

1770 mm - von 1690-1850 mm verstellbar

1900 mm - von 1820-1980 mm verstellbar

Material/Oberfläche

MS=Messing



MS7



MS10



MSPVD22

Weitere Längen finden Sie in unseren Duschenwelten 2013/14 auf Seite 181. Andere Längen auf Anfrage!

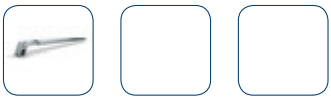

■ Stabilisierungsstangen

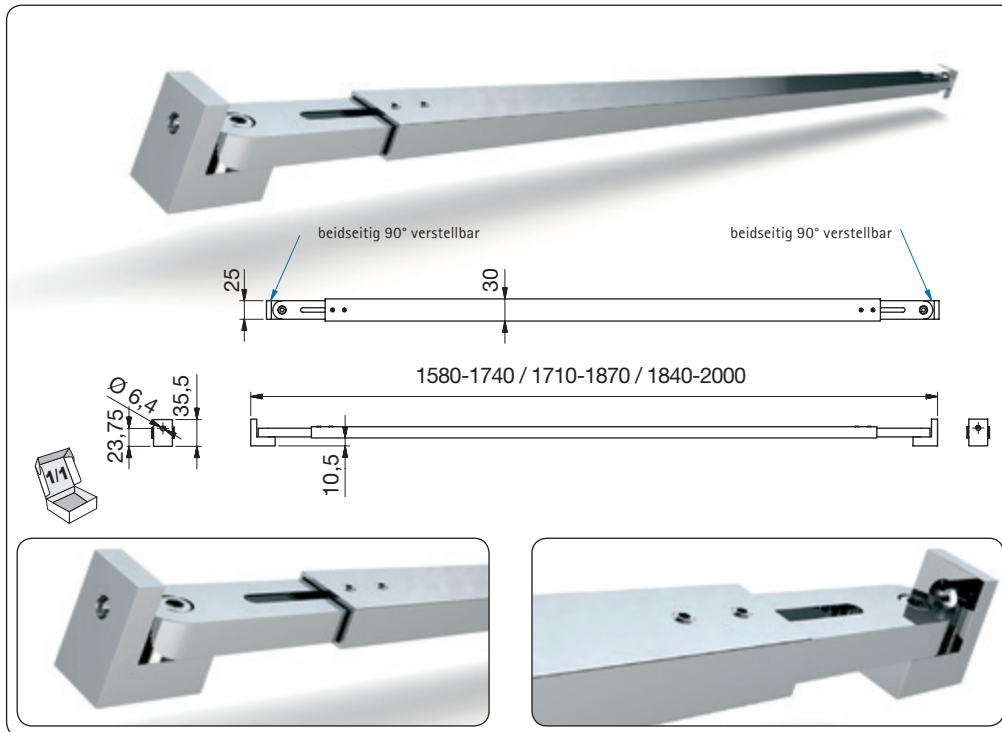

Art. Nr.: 8477

Stabilisierungsstange, Wand-Wand

Längen:

1660 mm - von 1580-1740 mm verstellbar

1790 mm - von 1710-1870 mm verstellbar

1920 mm - von 1840-2000 mm verstellbar

Material/Oberfläche

MS=Messing



MS7



MS10



MSPVD22

Weitere Längen finden Sie in unseren Duschenwelten 2013/14 auf Seite 182. Andere Längen auf Anfrage!

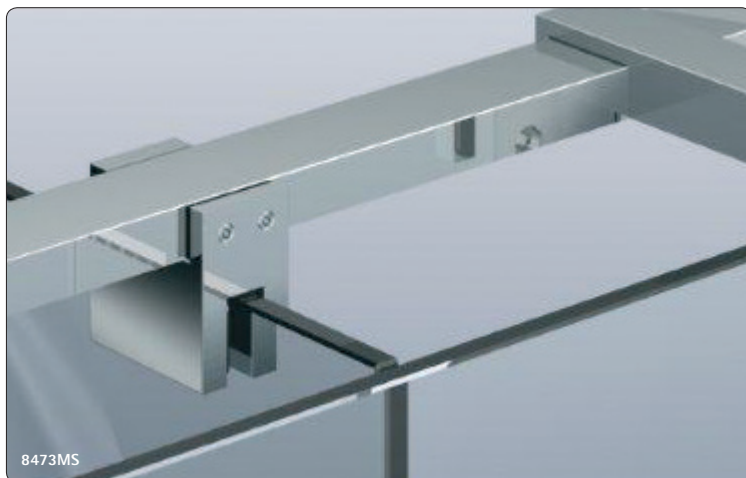

8473MS

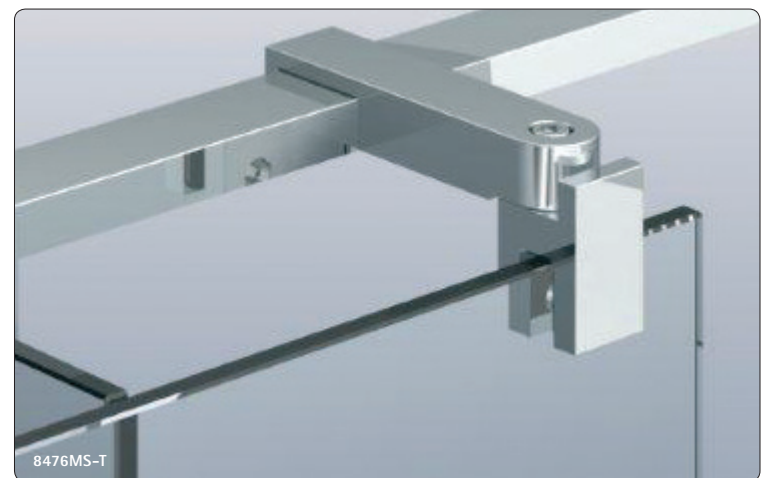

8476MS-T



Zubehör

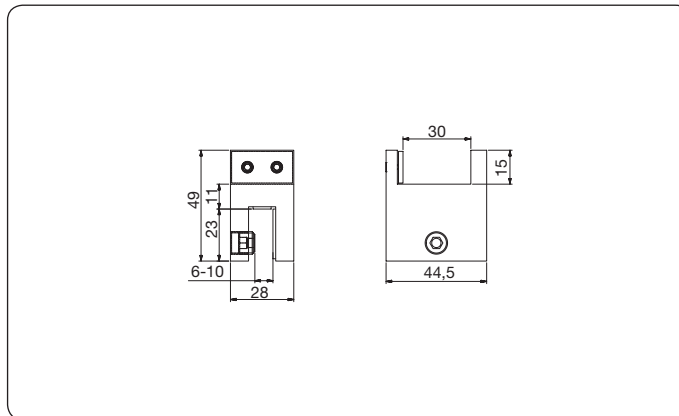

Art. Nr.: 8473

Glasplattenhalter für 8474MS, 8475MS und 8477MS

Plattendicke 6-10 mm

Material/Oberfläche MS= Messing



MS7



MS10



MSPVD22

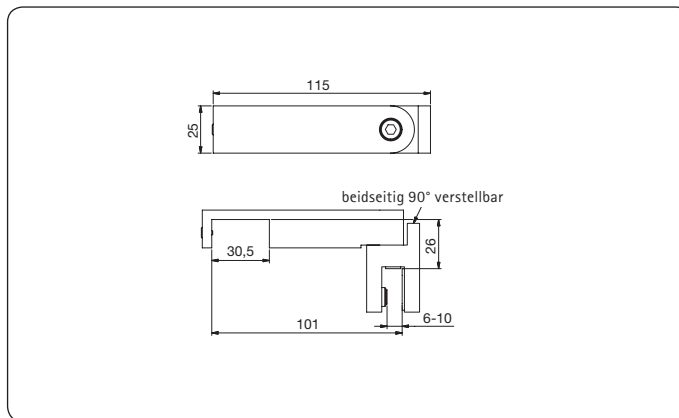

Art. Nr.: 8476-T

T-Stück für 8474MS, 8475MS und 8477MS

Plattendicke 6-10 mm

Material/Oberfläche MS= Messing



MS7



MS10



MSPVD22

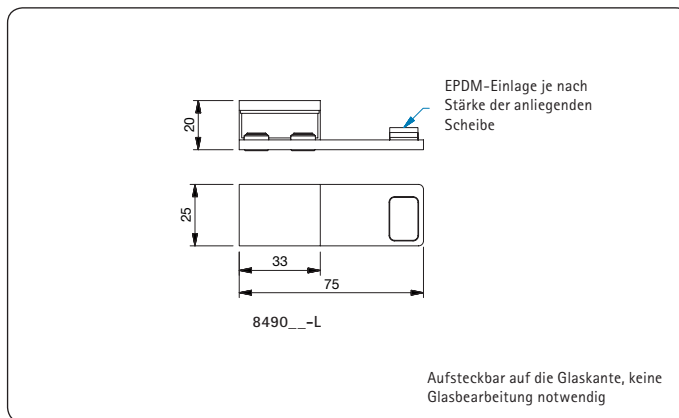
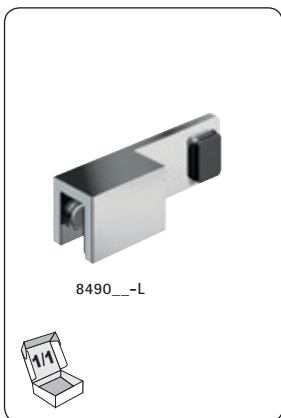

Art. Nr.: 8490__-L /8490__-R

Überdrückungsschutz (Türanschlag)
linke und rechte Variante

Plattendicke 6-10 mm

Material/Oberfläche MS= Messing



MS7

Zubehör

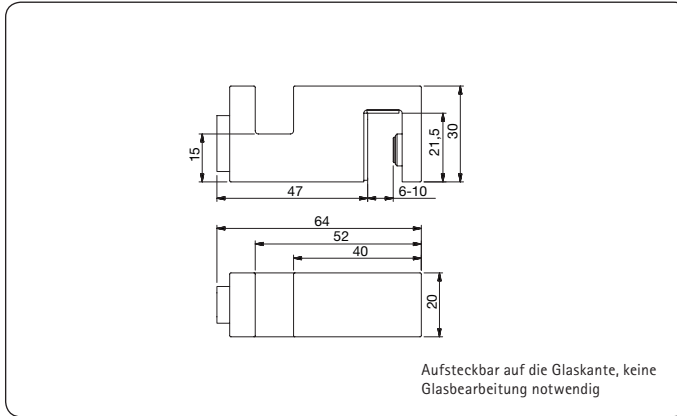
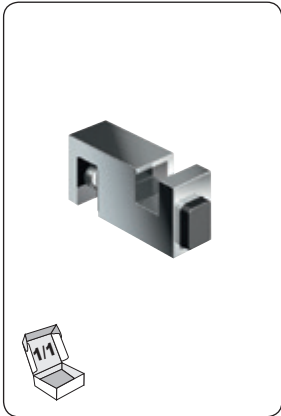

Art. Nr.: 8499

Türanschlagpuffer mit Überdrückungsschutz

Plattendicke  6-10 mm

Material/Oberfläche MS= Messing



MS7

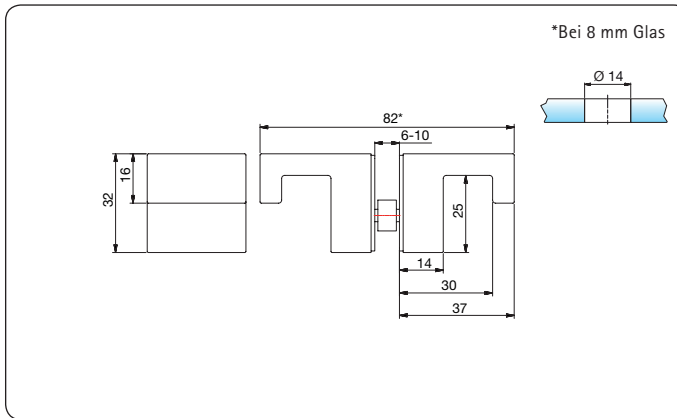
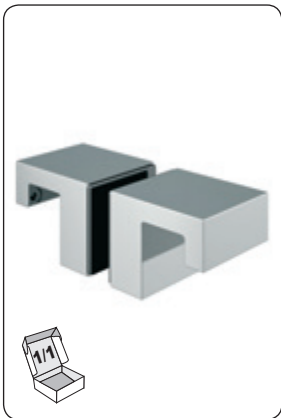

Art. Nr.: 8252

Glastürgriff beidseitig

Plattendicke  6-10 mm

Material/Oberfläche MS = Messing



MS7

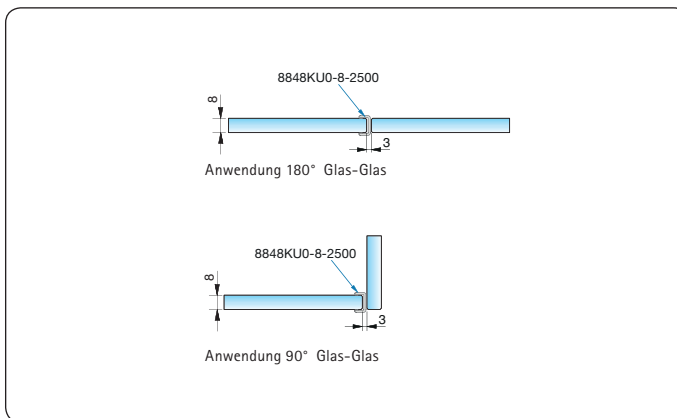

Art. Nr.: 8848__-8-2500

Sichtschutzprofil Länge = 2500 mm,

Plattendicke  8 mm

Material/Oberfläche KU = Kunststoff



KUO

Weitere Stabilisierungsstangen und Aussteifungsmöglichkeiten, Überdrückungs- und Anschlagschutz, sowie Griffe finden Sie in unseren Duschenwelten 2013/2014.

Profile und Trenwände



■ Bodenhalter

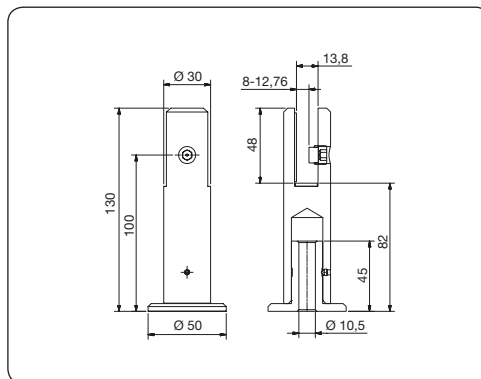

Art. Nr.: 31322

Bodenhalter für vertikale Glasbefestigung

Plattendicke  8- 12,76 mm

Material/Oberfläche VA = Edelstahl



VA2

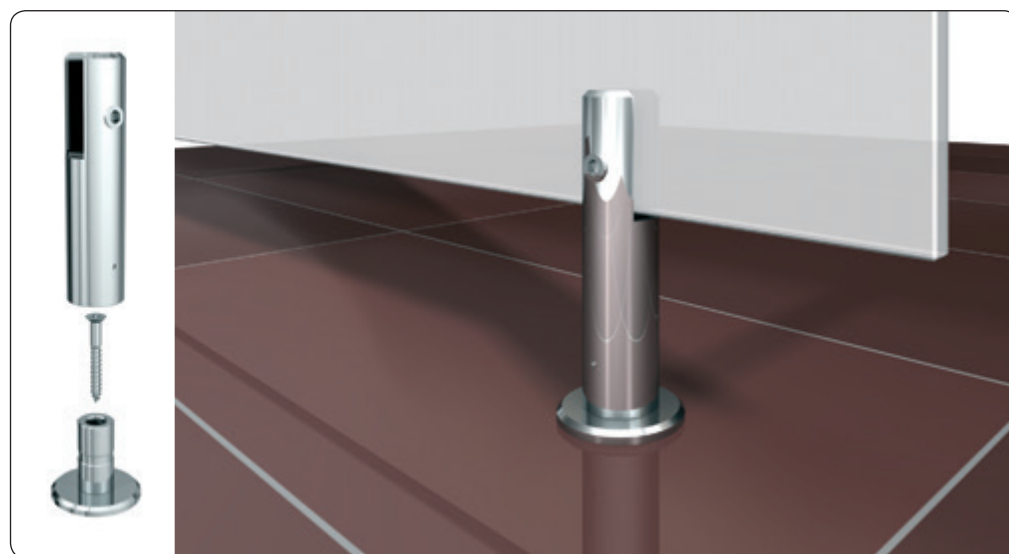



■ Bodenhalter



Profile und
Trennwände

Achtung: Je nach Belastung, Türgröße und Anforderung an die Steifigkeit, werden zusätzliche Aussteifungsartikel benötigt. Je nach Größe der Seitenteile ist die Anzahl der Bodenhalter anzupassen. Türen sind in ihrem Öffnungsweg zu begrenzen. Dazu ist ein Überdrückungs- und Anschlagsschutz zu verwenden. Wir beraten Sie hierzu gerne.



■ Toiletten-/Umkleidekabinenverriegelung

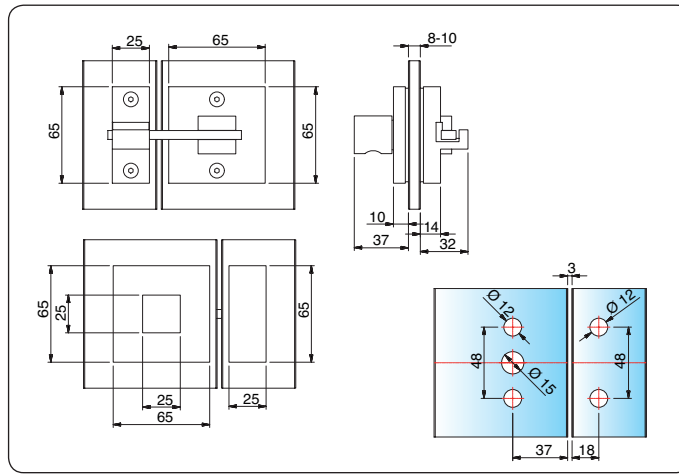
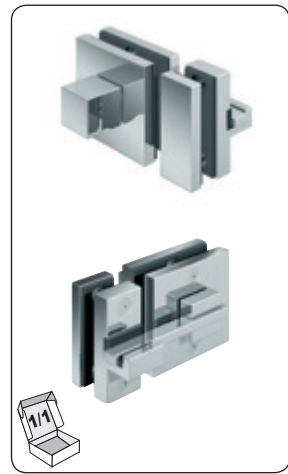

Art. Nr.: 8374

Glastür-Riegel mit Schloss und Gegenkasten mit Drehknopf außen und Verriegelungsstift innen

Plattendicke

8/10 mm

Material/Oberfläche

MS= Messing



MS7





■ Toiletten-/Umkleidekabinenverriegelung

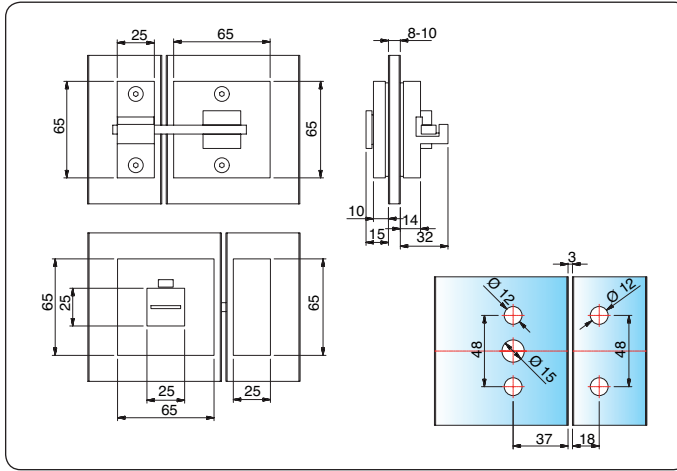
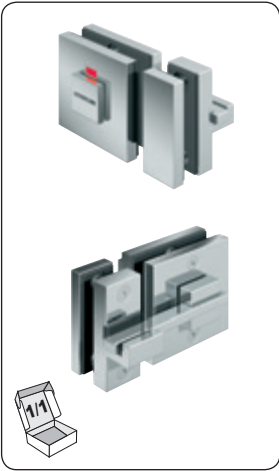

Art. Nr.: 8375

Glastür-Riegel mit Schloss und Gegenkasten mit Schauscheibe rot/grün und Verriegelungsstift innen

Plattendicke  8/10 mm

Material/Oberfläche MS= Messing



MS7

Profile und
Trennwände

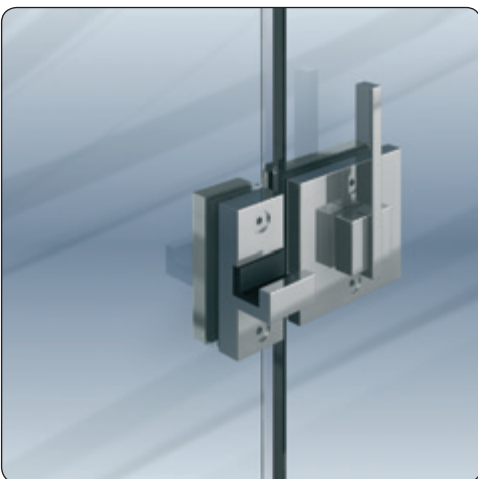
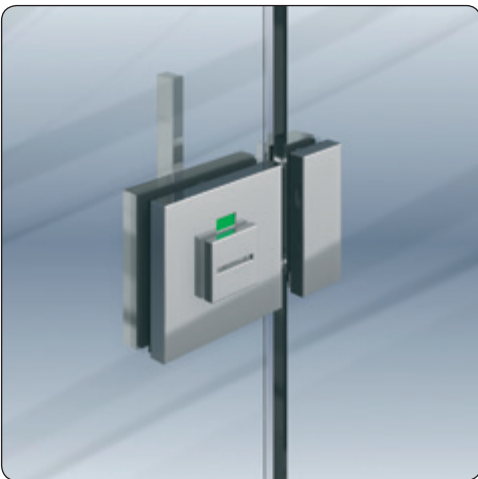

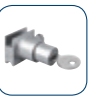
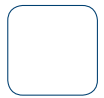
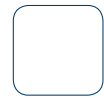

Glasschiebetür-
beschläge

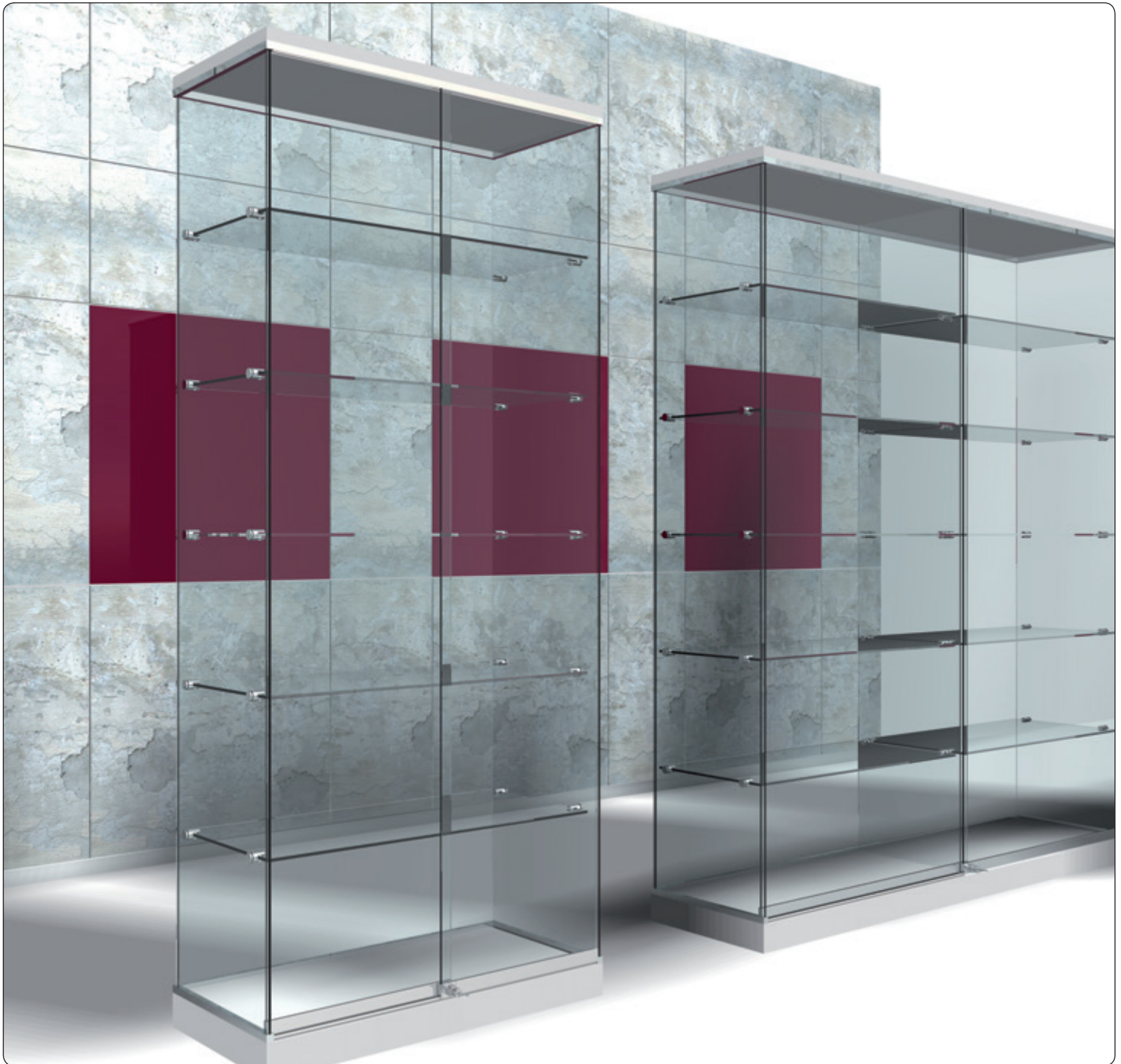

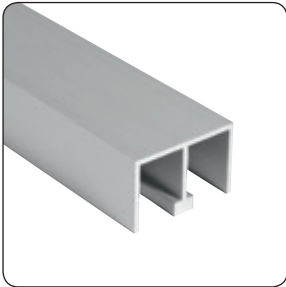
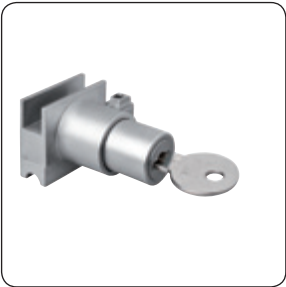

■ Glasschiebetürbeschläge



■ Inhalt



| | |
|--|-----|
| ■ Schiebetürbeschlag Modell 2100 | 108 |
| Schiebetürbeschlag Modell 2200 | 118 |
| Zubehör | 124 |

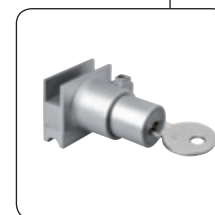



■ Kurzbezeichnungen für Material- und Ausführungsarten

ZN = Zink (ZAMAK®)

 ZN1 = mattverchromt

 ZN3 = glanzverchromt

ST = Stahl

 ST8 = verzinkt

E = Aluminium

 E3/1 = mattverchromt

 E3/50 = glanzverchromt

 E6/EV1 = Alu-Optik

KU = Kunststoff

 KU0 = transparent

 KU1 = weiß

 KU2 = braun

 KU4 = silbergrau

 KU6 = mattverchromt



■ Schiebetürbeschlag Modell 2100 - für Plattendicke 5–8 mm

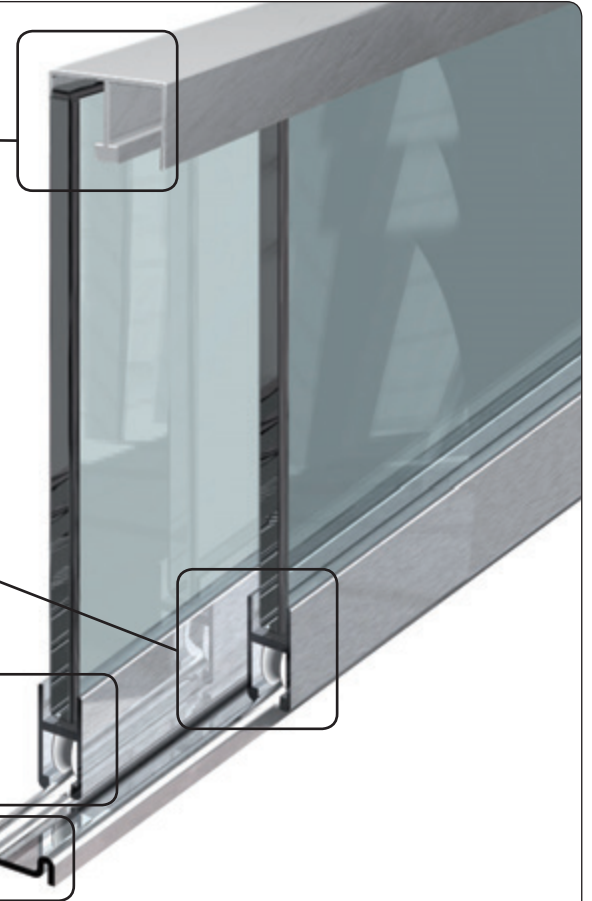
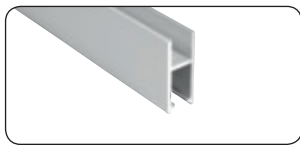
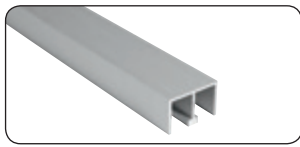

Technische Angaben

Maximale Belastung pro Flügel

2 x 2103 ST8 = ca. 25 kg

4 x 2103 ST8 = ca. 50 kg

Berechnung des Glasmaßes
ohne Klemmprofil:

Einbauhöhe - 31 mm = Glasmaß

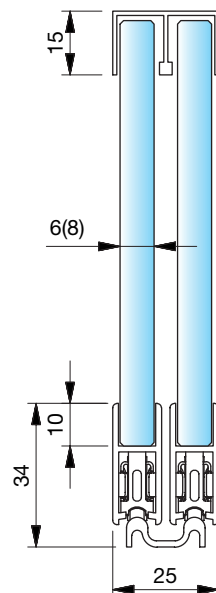



■ Schiebetürbeschlag Modell 2100

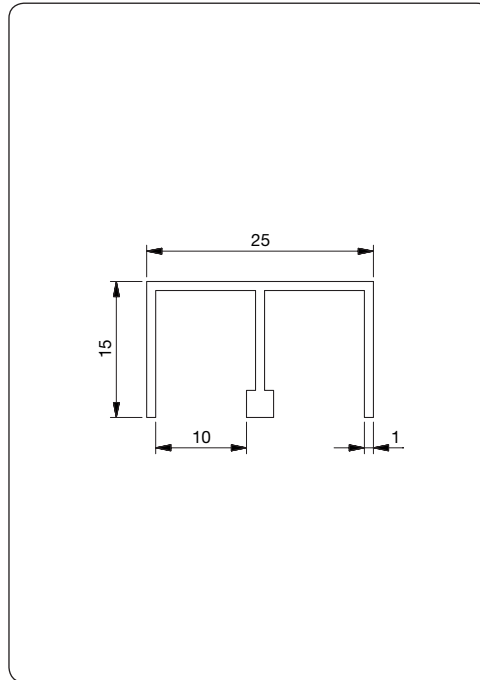
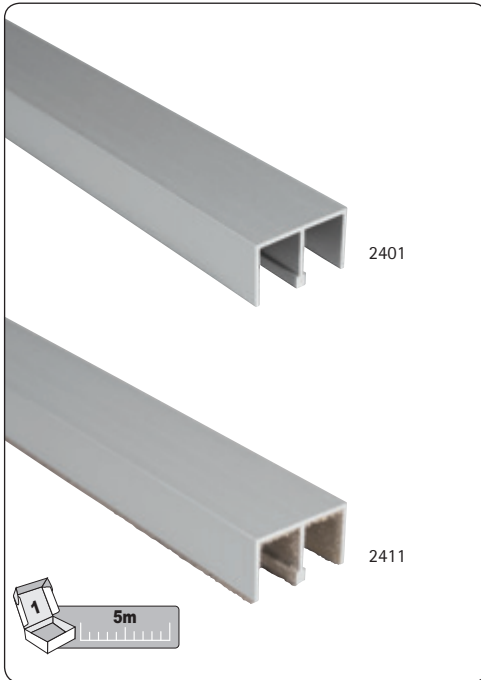

Art. Nr.: 2401

Obere Doppel-U-Führungsschiene, ungebohrt

Plattendicke  5-8 mm

Art. Nr.: 2411

Obere Doppel-U-Führungsschiene, ungebohrt
samtiert für ruhigen Lauf

Plattendicke  5-8 mm

Material/Oberfläche E = Aluminium



E6/EV1

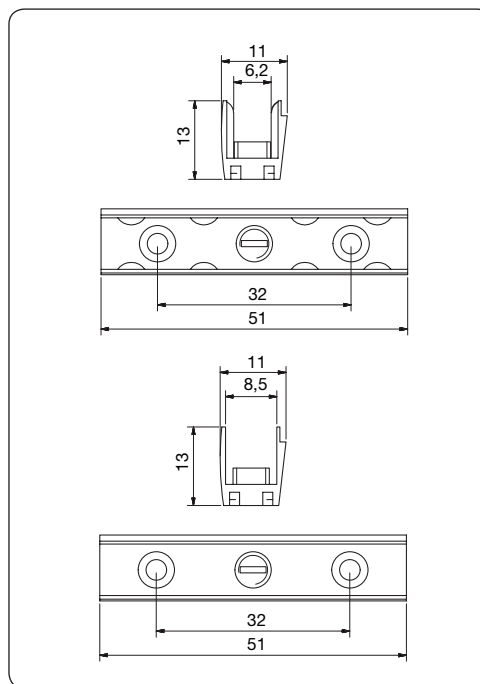
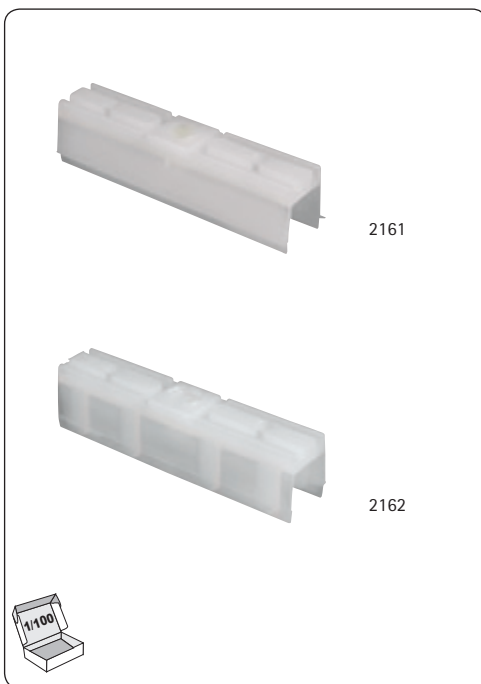

Art. Nr.: 2161

Aushängesicherung/Klapperschutz

Plattendicke  6 mm

Art. Nr.: 2162

Aushängesicherung/Klapperschutz

Plattendicke  8 mm

Material/Oberfläche KU = Kunststoff



KUO



■ Schiebetürbeschlag Modell 2100

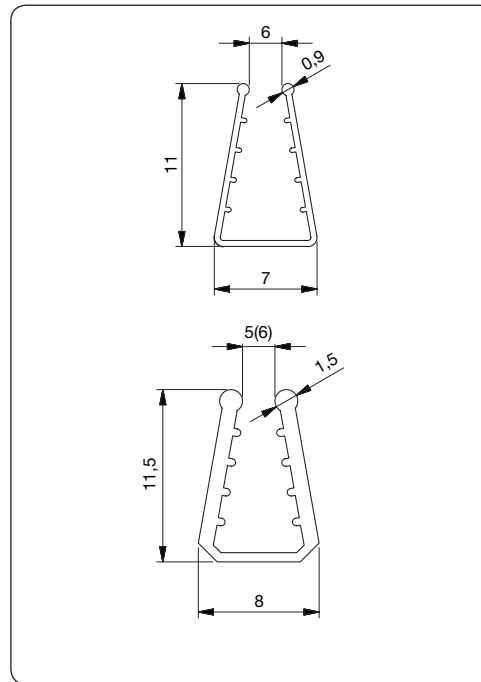
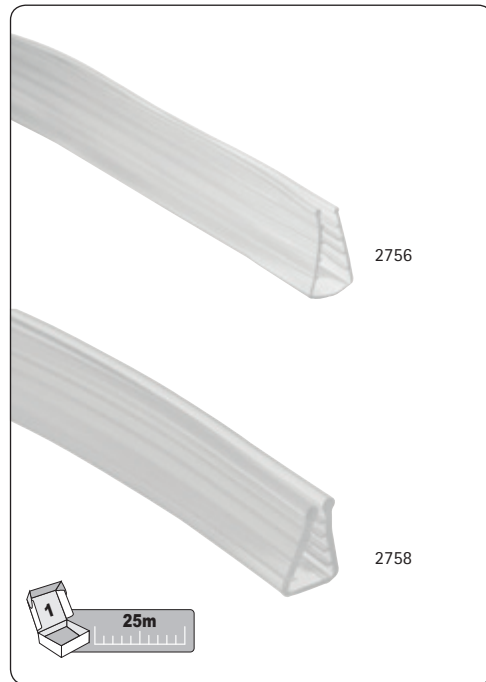

Art. Nr.: 2756

Klemmprofil

Plattendicke  6 mm

Eingesetzter Laufsuh: 2122

Art. Nr.: 2758

Klemmprofil

Plattendicke  5 mm

Eingesetzter Laufsuh: 2122

Plattendicke  6 mm

Eingesetzter Laufsuh: 2124

Material/Oberfläche KU = Kunststoff



KUO

Art. Nr.: 2122

Laufsuh mit Schutzfolie

Plattendicke  5-6 mm

Art. Nr.: 2124

Laufsuh mit Schutzfolie

Plattendicke  6-8 mm

Material/Oberfläche E = Aluminium



E6/EV1

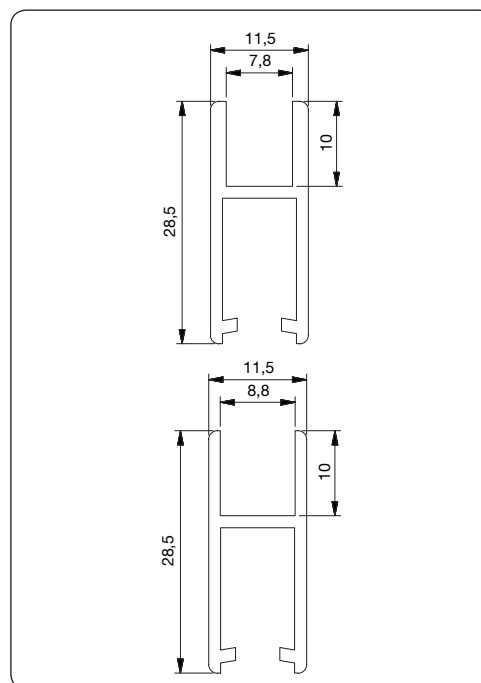
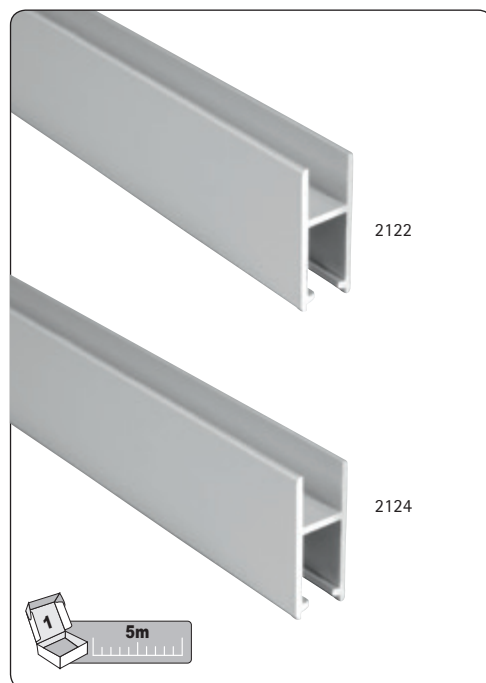



■ Schiebetürbeschlag Modell 2100

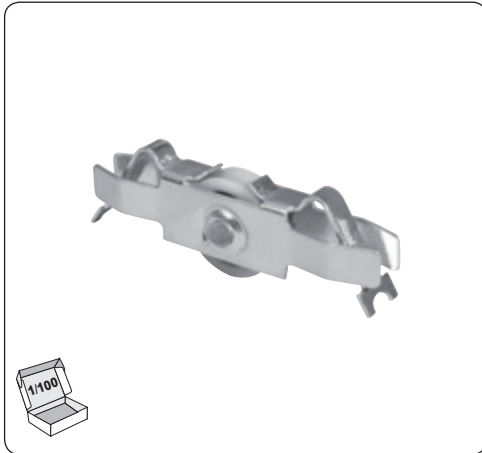

Art. Nr.: 2103

Rolleneinsatz mit kunststoffummantelter
Stahlkugellagerrolle

Material/Oberfläche ST = Stahl



ST8



2145

Zubehör

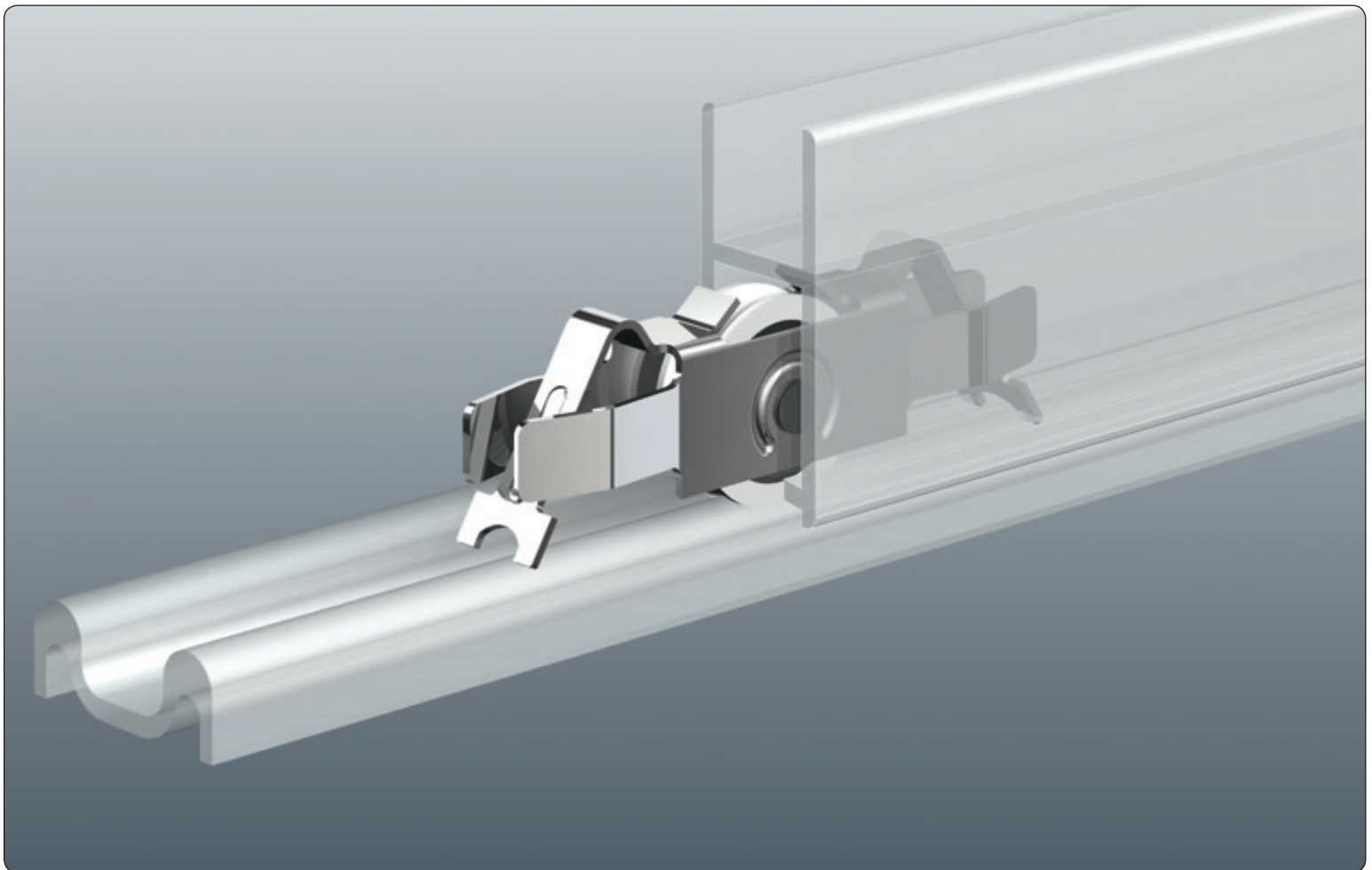



Schiebetürbeschlag Modell 2100

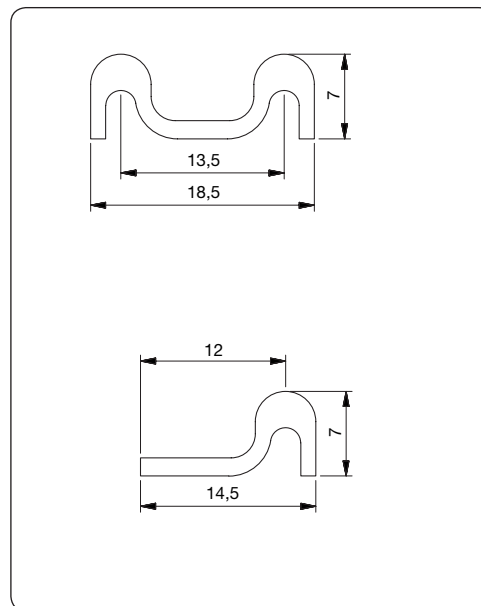
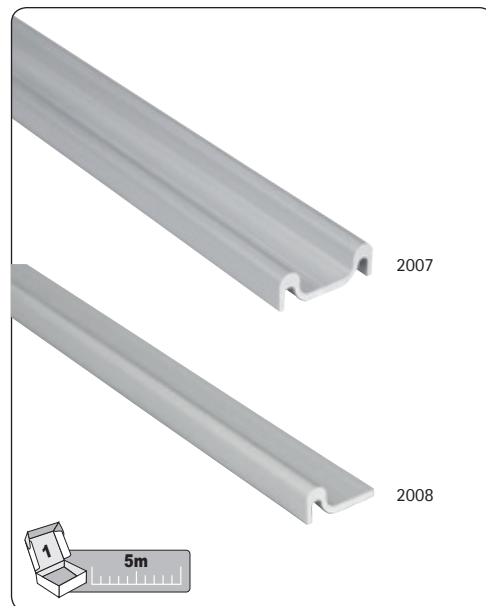

Art. Nr.: 2007

Untere Doppellaufschiene
mit Doppelklebeband

Art. Nr.: 2008

Untere Einbahnlaufschiene
mit Doppelklebeband

Material/Oberfläche E = Aluminium



E6/EV1



Zubehör

5015, 5016

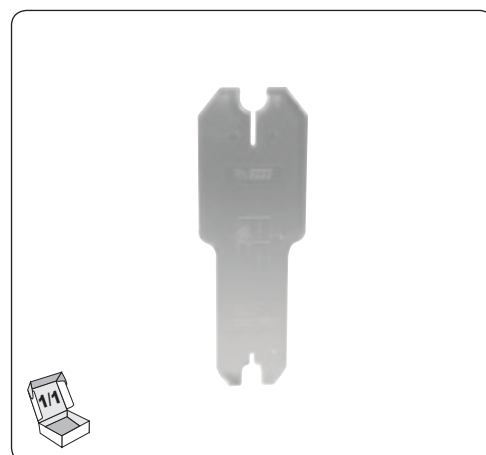

Gebrauchsanweisung

1. Rolleneinsatz auf das Montagewerkzeug aufstecken und in den Laufschuh einschieben
2. Montagewerkzeug abziehen

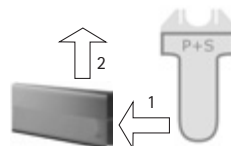

Art. Nr.: 2145

Montagewerkzeug aus Makrolon
für Rolleneinsatz: 2103

Material/Oberfläche KU = Kunststoff



KUO



■ Schiebetürbeschlag Modell 2100

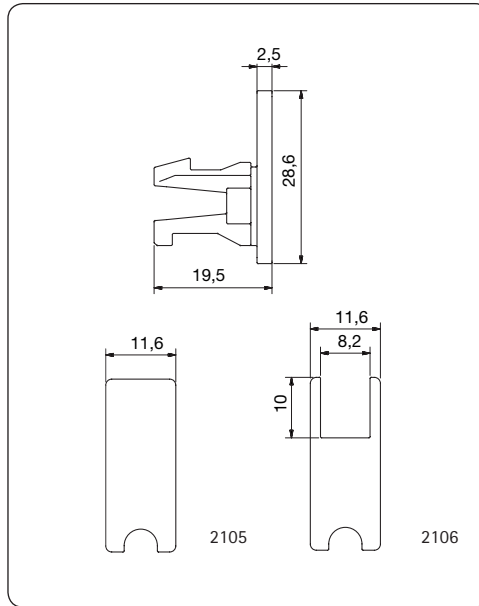
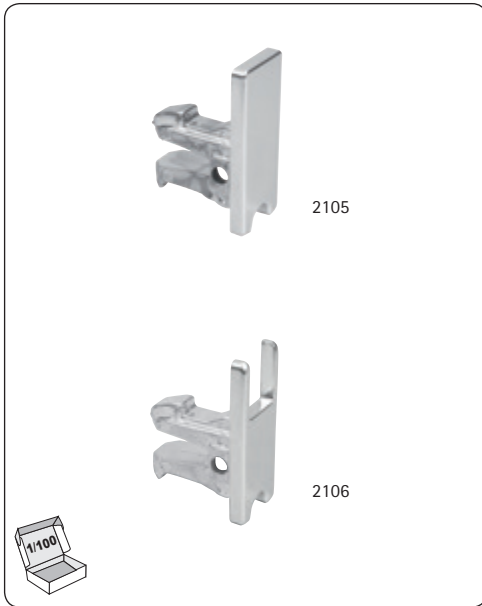

Art. Nr.: 2105

Endstück

Art. Nr.: 2106

Endstück, ausgeklinkt

Material/Oberfläche KU = Kunststoff



KU6

Glasschiebetür-
beschläge





■ Schiebetürbeschlag Modell 2100

Art. Nr.: 2159

Laufschuhgriff

Plattendicke  5-8 mm

Art. Nr.: 2160

Laufschuhgriff, ausgeklinkt

Plattendicke  5-8 mm

Material/Oberfläche KU = Kunststoff



KU6

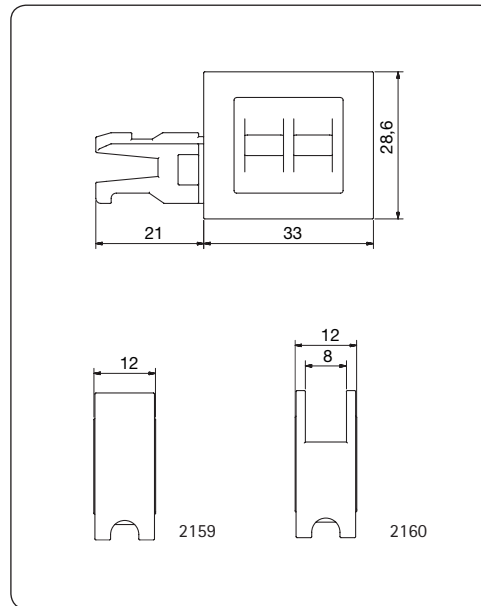
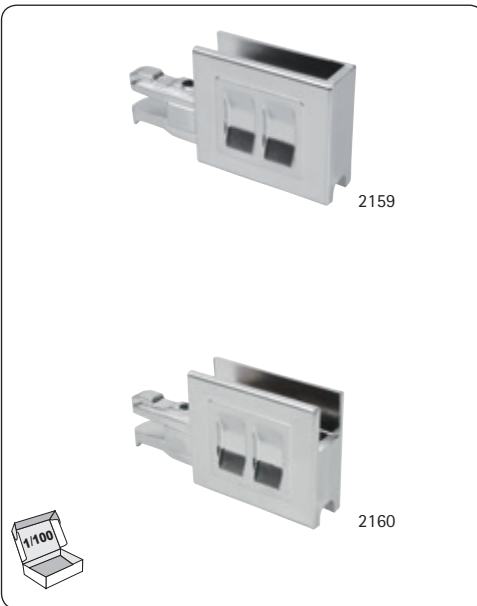



■ Schiebetürbeschlag Modell 2100

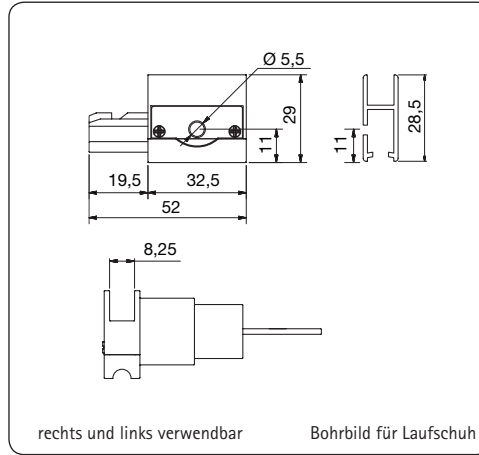
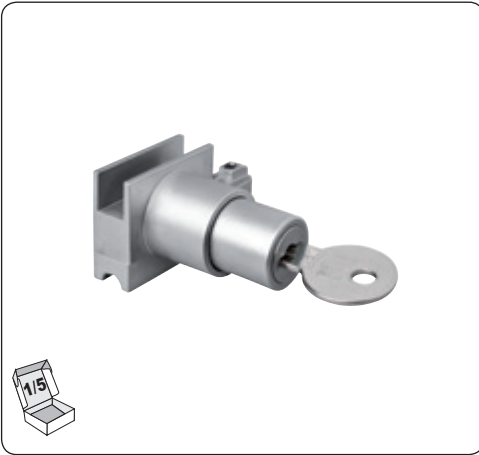

Art. Nr.: 2116

Laufschuhschloß mit zwei
Schlüsseln, ausgeklinkt

2116-G gleichschließend

2116-V verschiedenschließend

Material/Oberfläche ZN = Zink



ZN1

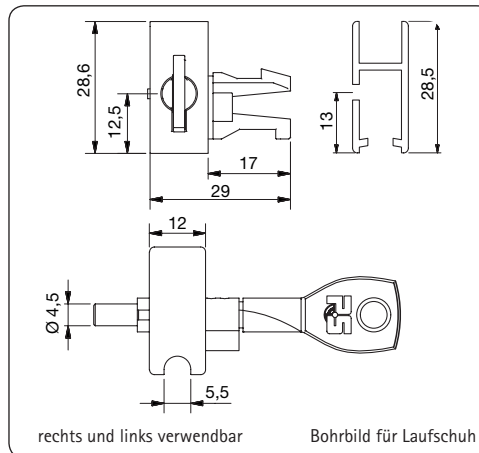
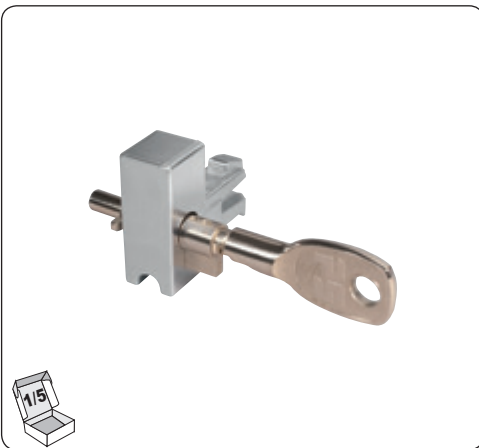

Art. Nr.: 2107

Sicherheits-Laufschuhschloß
mit zwei Schlüsseln und Zylindersperrerr

2107-G gleichschließend

2107-V verschiedenschließend

Material/Oberfläche KU = Kunststoff



KU6



■ Schiebetürbeschlag Modell 2100

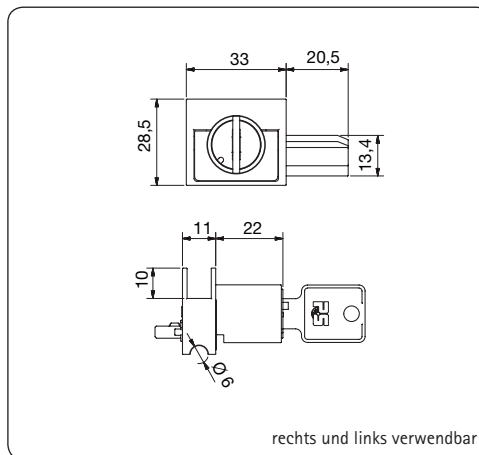
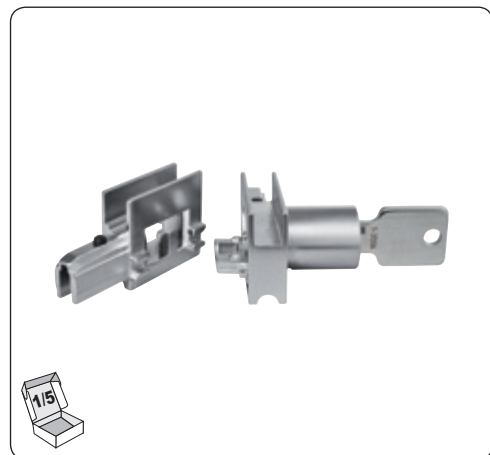

Art. Nr.: 2126

Sicherheits-Laufschuhschloß
mit Schlüssel, ausgeklinkt

2126-G gleichschließend

2126-V verschiedenschließend

Material/Oberfläche ZN = Zink



ZN1

Art. Nr.: 2127

Demontagestift für Art. Nr.: 2126

Material/Oberfläche ST = Stahl



ST8

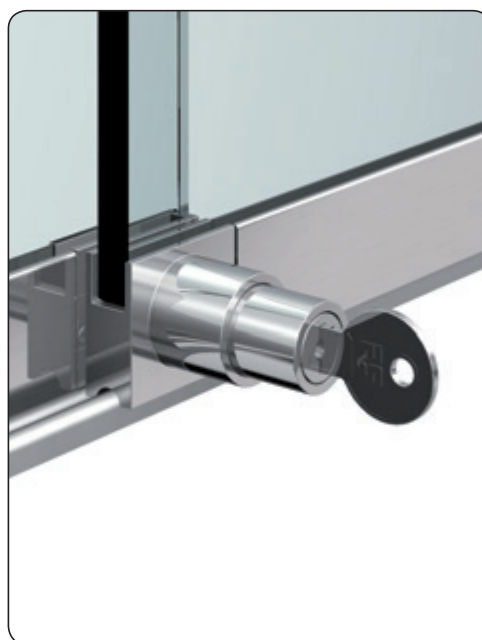
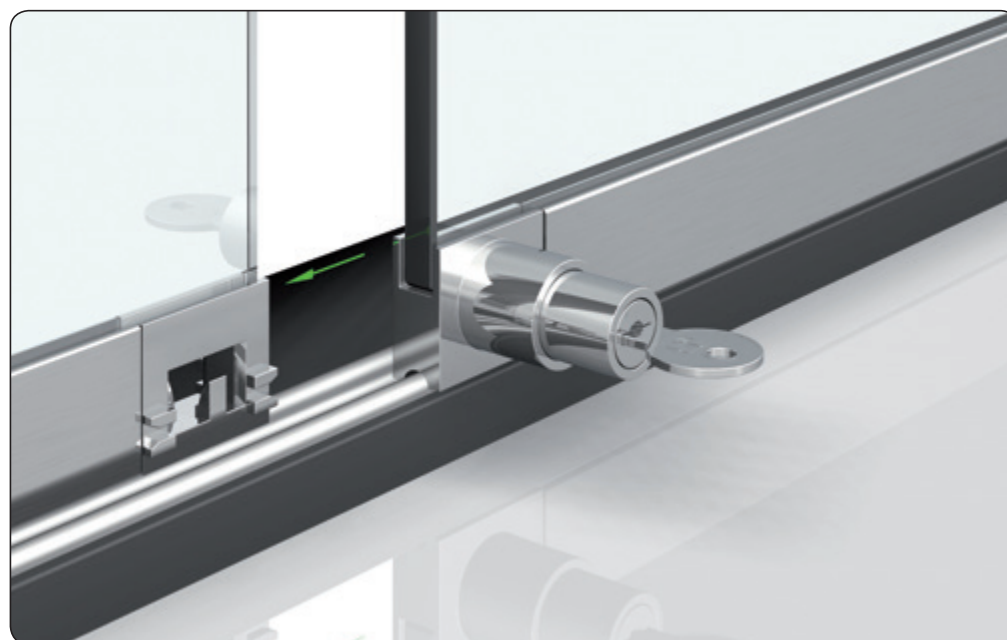



■ Schiebetürbeschlag Modell 2100

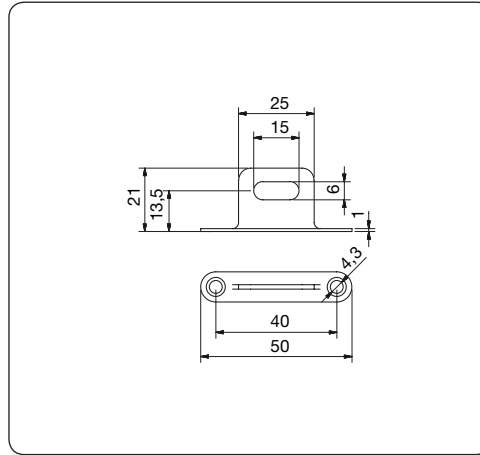
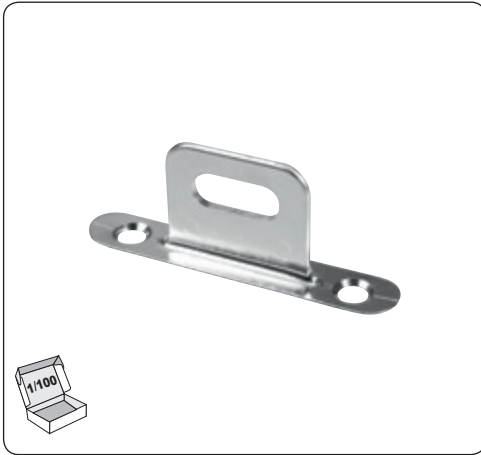

Art. Nr.: 2962

Aushängesicherung (Diebstahlsicherung)

Material/Oberfläche

ZN = Zink



ZN1

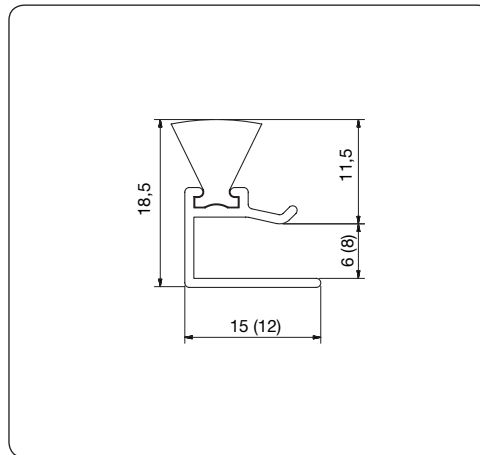
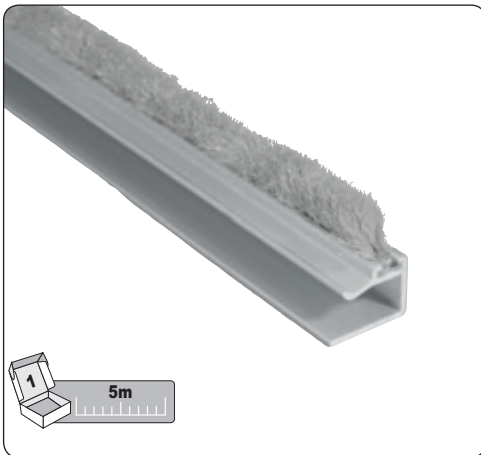

Art. Nr.: 2964

Staubschutzleiste mit grauen Haarborsten

Plattendicke



6 mm

Art. Nr.: 2965

Staubschutzleiste mit grauen Haarborsten

Plattendicke



8 mm

Material/Oberfläche

E = Aluminium



E6/EV1



■ Schiebetürbeschlag Modell 2200 - für Plattendicke 5–6 mm

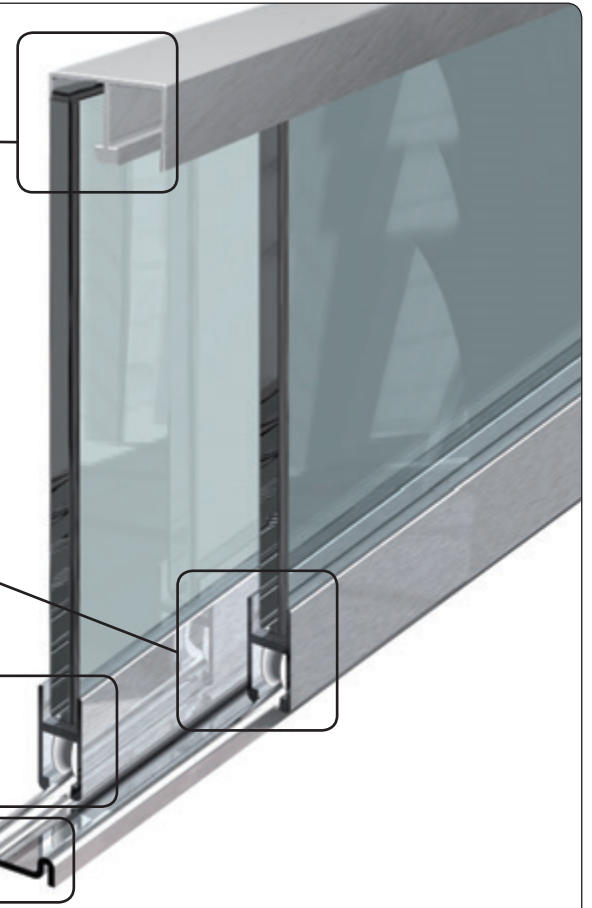
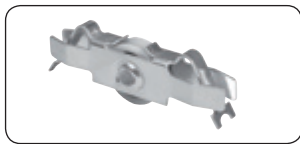
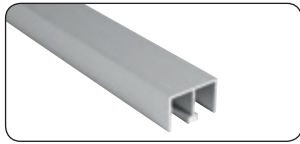

Technische Angaben

Maximale Belastung pro Flügel

2 x 2103 ST8 = ca. 25 kg

4 x 2103 ST8 = ca. 50 kg

Berechnung des Glasmaßes
ohne Klemmprofil:

Einbauhöhe - 29 mm = Glasmaß

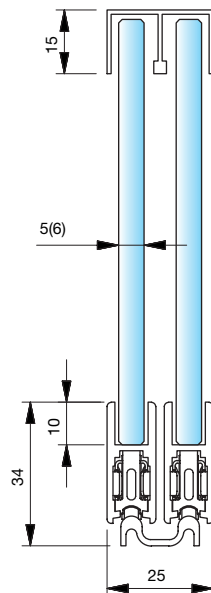



■ Schiebetürbeschlag Modell 2200

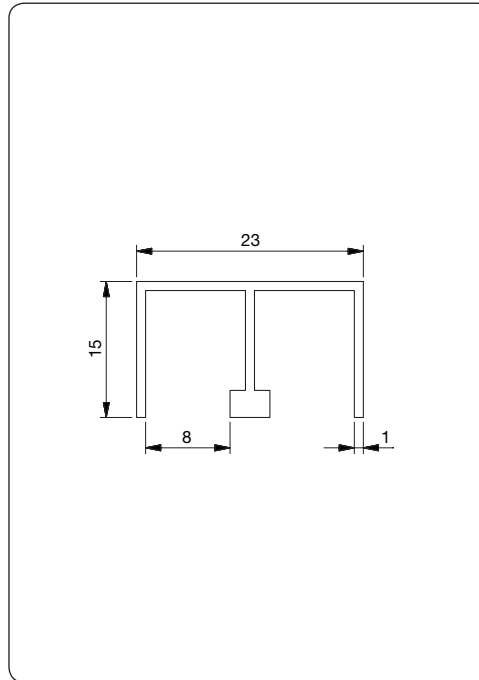
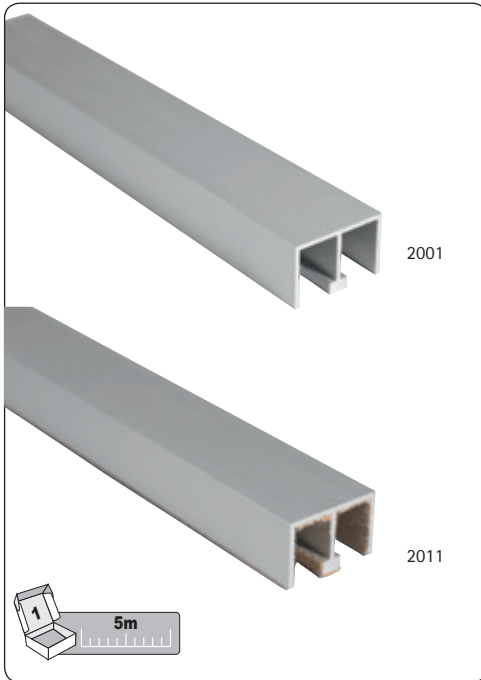

Art. Nr.: 2001

Obere Doppel-U-Führungsschiene, ungebohrt

Plattendicke  5-6 mm

Art. Nr.: 2011

Obere Doppel-U-Führungsschiene, ungebohrt
samtiert für ruhigen Lauf

Plattendicke  5-6 mm

Material/Oberfläche E = Aluminium



E6/EV1

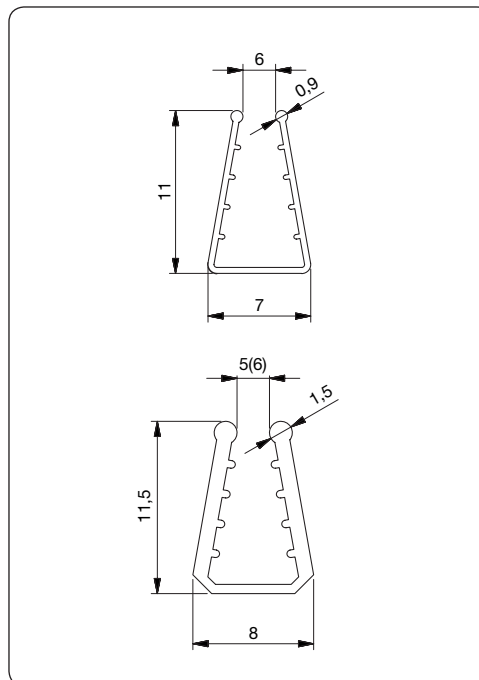
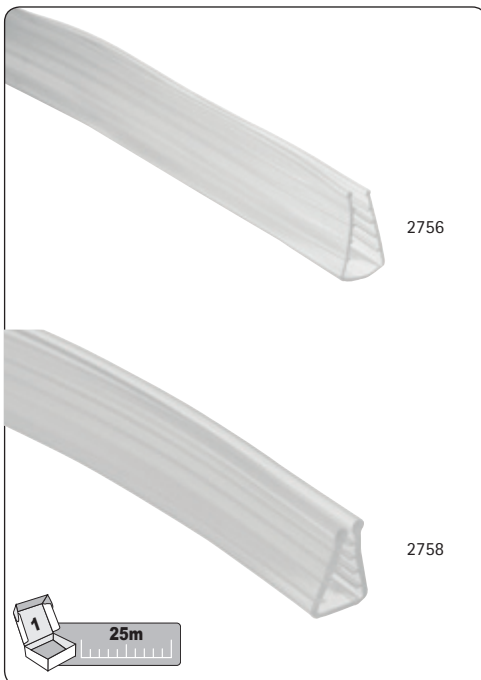

Art. Nr.: 2756

Klemmprofil

Plattendicke  6 mm

Eingesetzter Laufsuh: 2222

Art. Nr.: 2758

Klemmprofil

Plattendicke  5 mm

Eingesetzter Laufsuh: 2222

Material/Oberfläche KU = Kunststoff



KUO



■ Schiebetürbeschlag Modell 2200

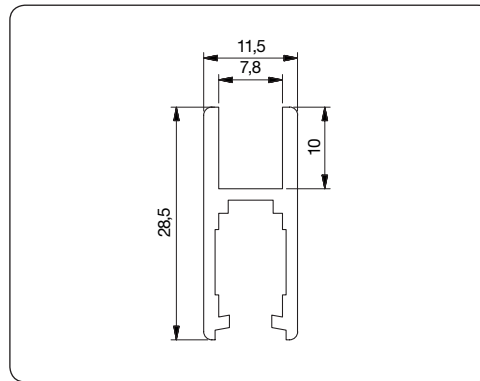
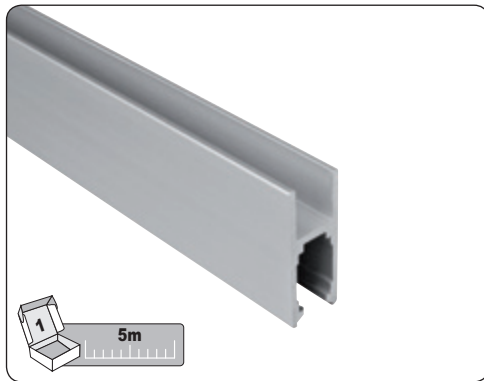

Art. Nr.: 2222

Laufschuh mit Schutzfolie

Plattendicke  5-6 mm

Material/Oberfläche E = Aluminium



E6/EV1

Glasschiebetür-
beschläge

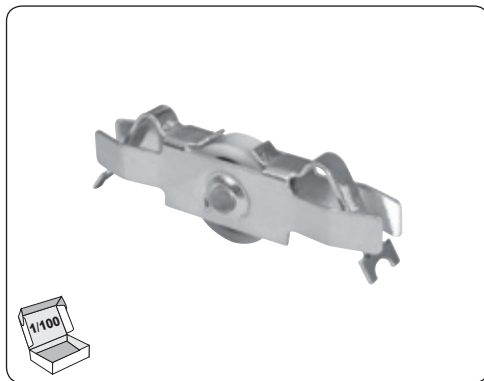

Art. Nr.: 2103

Rolleneinsatz mit kunststoffummantelter
Stahlkugellagerrolle

Material/Oberfläche ST = Stahl



ST8

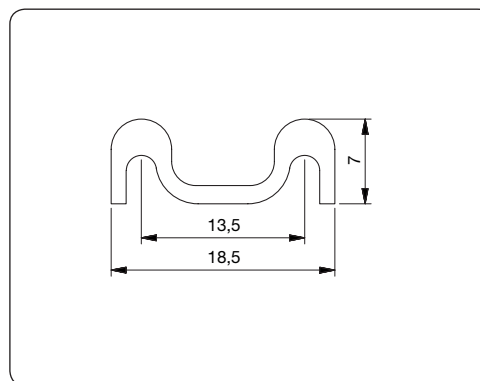
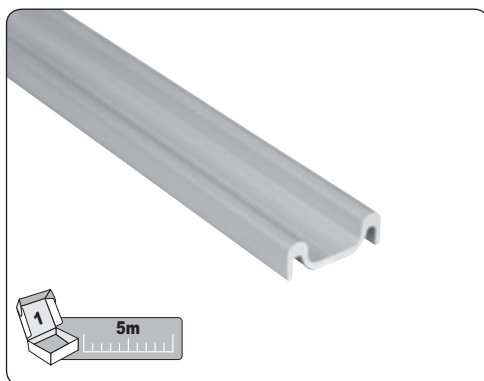
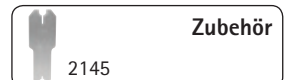

Art. Nr.: 2007

Untere Doppelaufschiene
mit Doppelklebeband

Material/Oberfläche E = Aluminium



E6/EV1



■ Schiebetürbeschlag Modell 2200

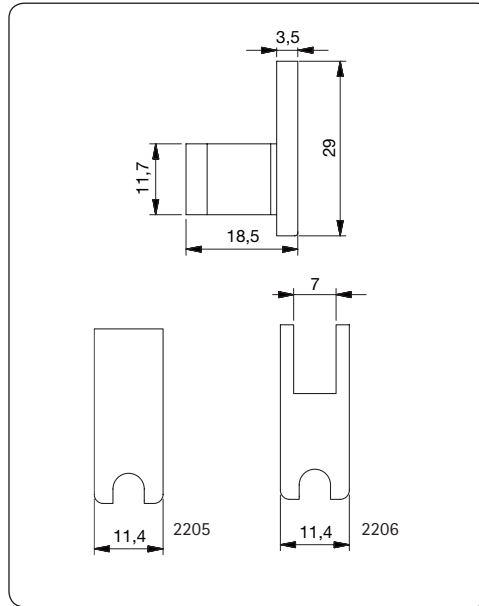
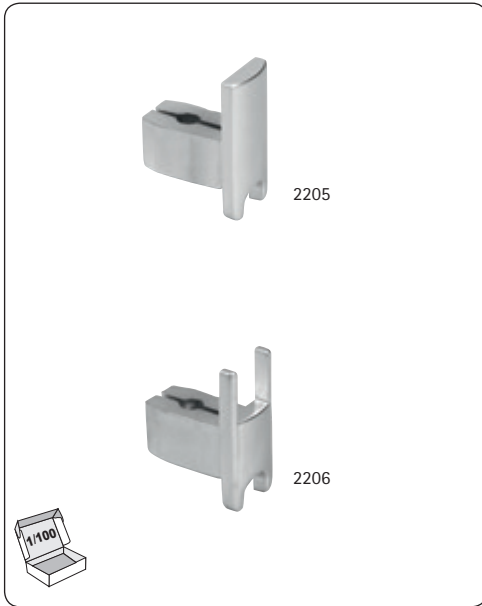

Art. Nr.: 2205

Endstück

Art. Nr.: 2206

Endstück, ausgeklinkt

Material/Oberfläche

KU = Kunststoff



KU6

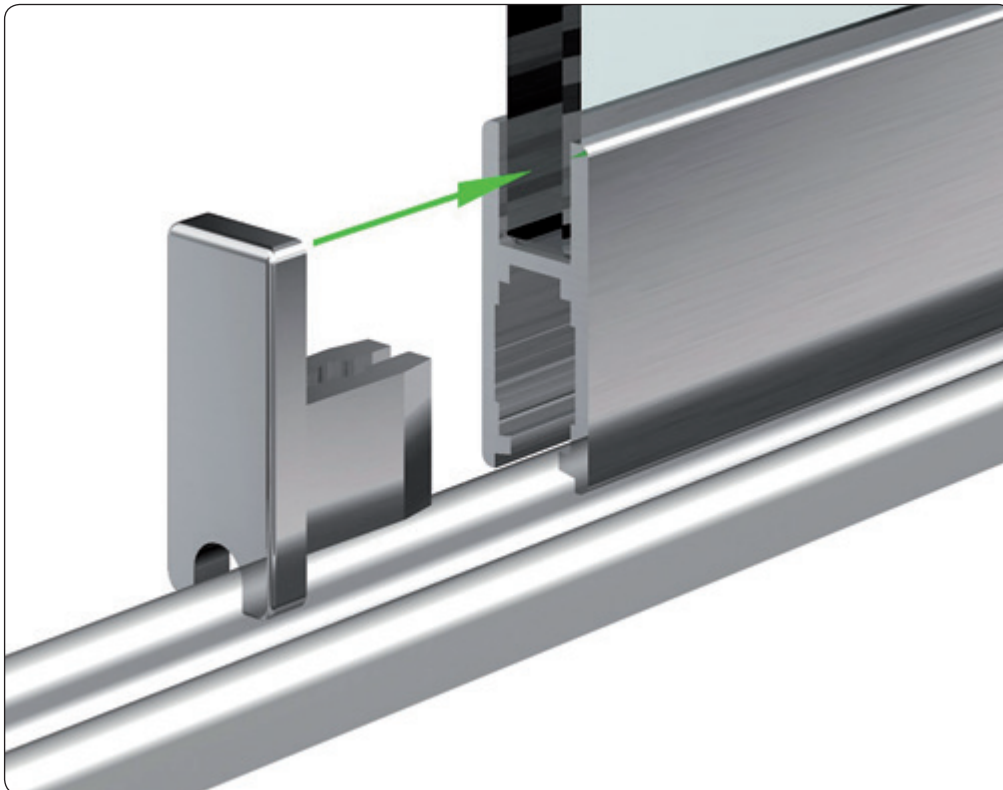



■ Schiebetürbeschlag Modell 2200

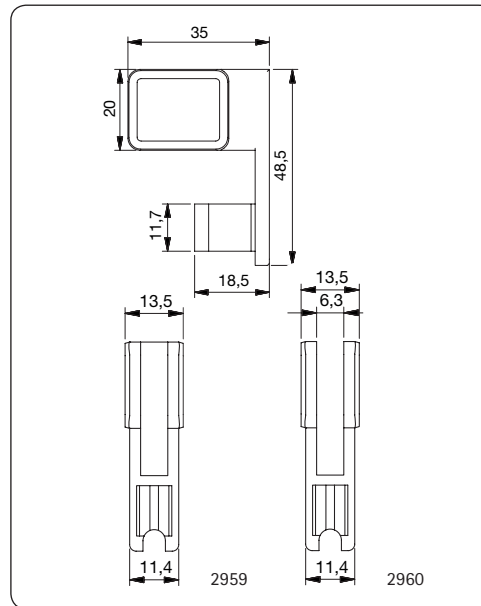
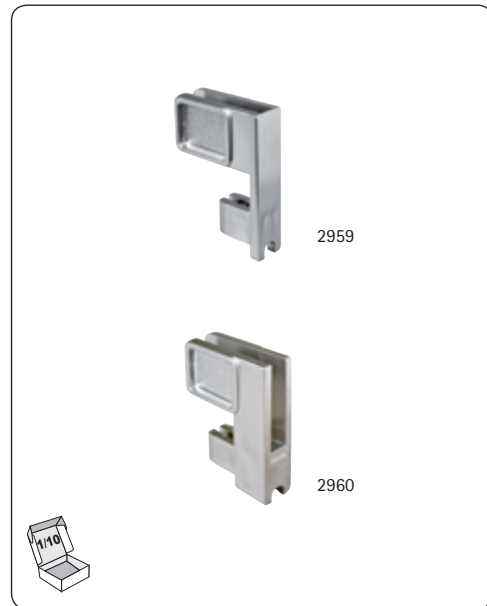

Art. Nr.: 2959

Laufschuhgriff

Plattendicke  5-6 mm

Art. Nr.: 2960

Laufschuhgriff, ausgeklinkt

Plattendicke  5-6 mm

Material/Oberfläche KU = Kunststoff



KU6

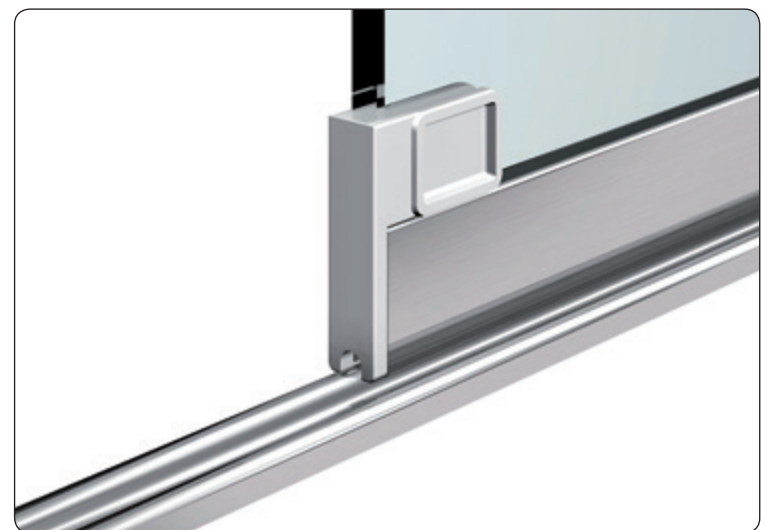
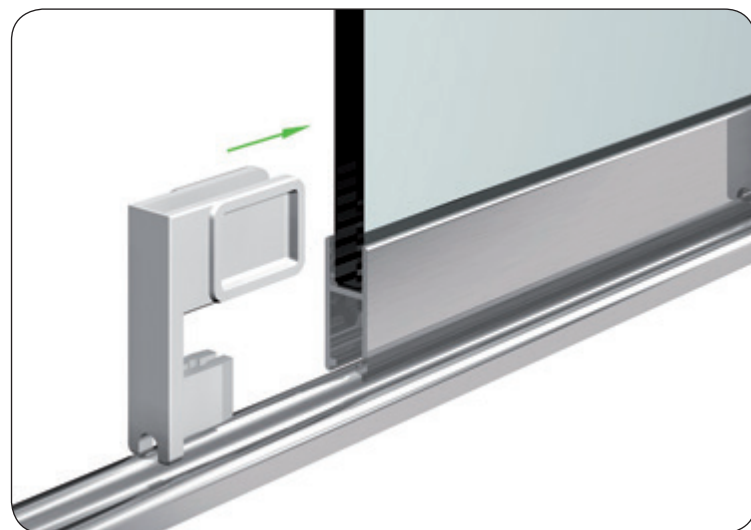

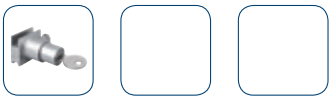

■ Schiebetürbeschlag Modell 2200

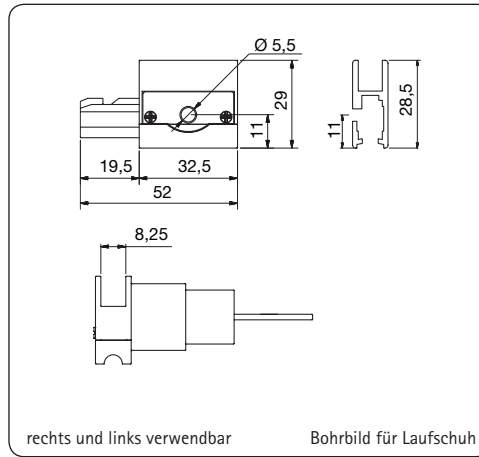
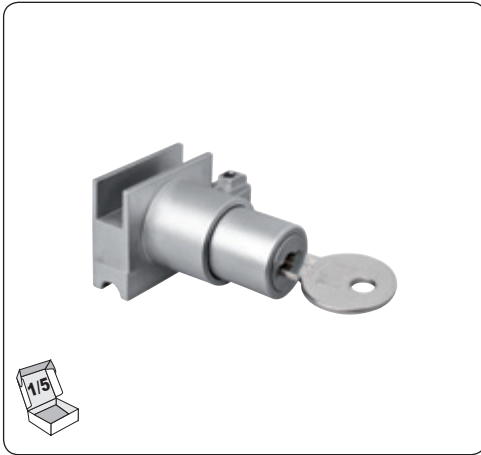

Art. Nr.: 2116

Laufschuhschloß mit zwei Schlüsseln, ausgeklinkt

2116-G gleichschließend

2116-V verschiedenschließend

Material/Oberfläche ZN = Zink



ZN1

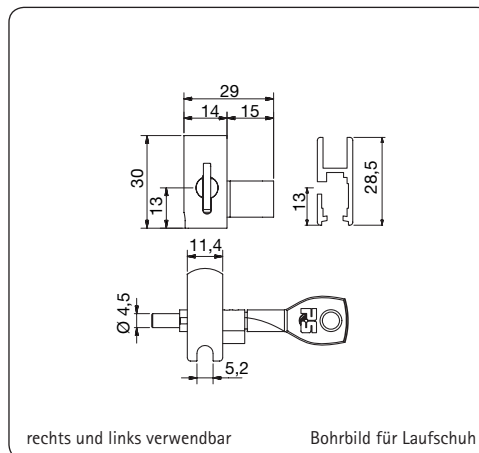
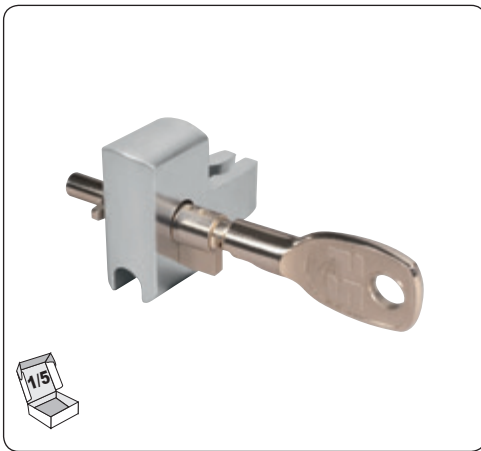

Art. Nr.: 2905

Laufschuhschloß mit zwei Schlüsseln

2905-G gleichschließend

2905-V verschiedenschließend

Material/Oberfläche KU = Kunststoff



KU6

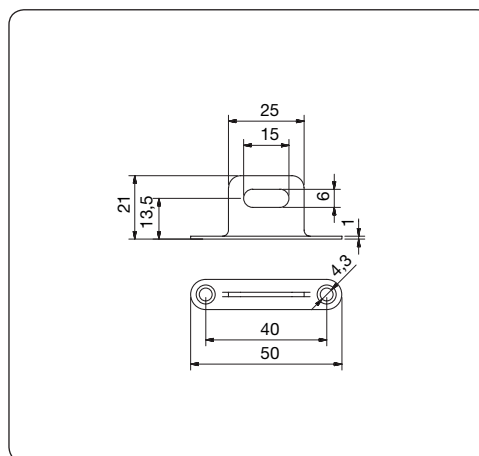
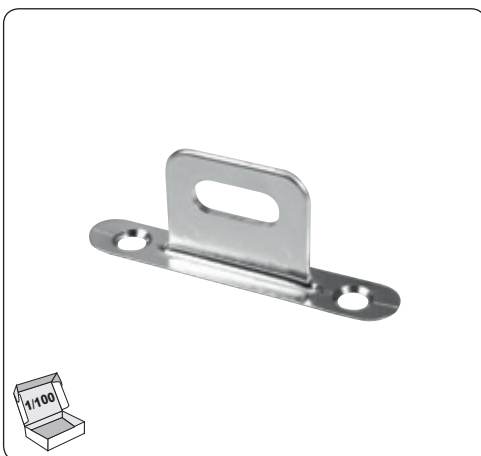

Art. Nr.: 2962

Aushängesicherung (Diebstahlsicherung)

Material/Oberfläche ZN = Zink



ZN1



Zubehör

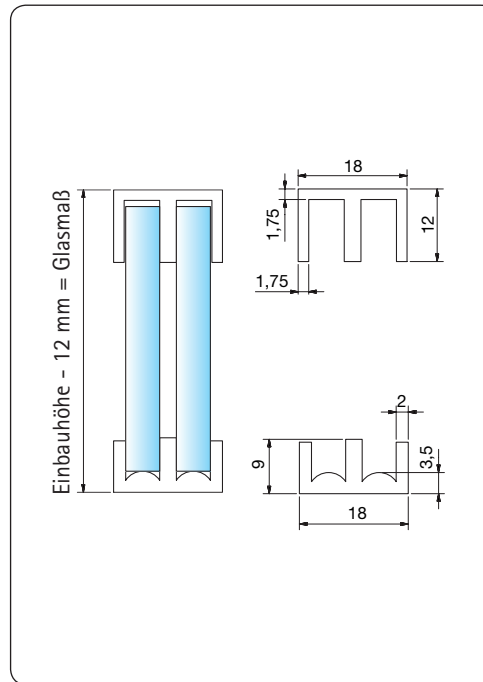

Art. Nr.: 2751

Obere Doppel-U-Führungsschiene

Plattendicke  4 mm

Art. Nr.: 2752

Untere Doppel-U-Gleitschiene

Plattendicke  4 mm

Berechnung des Glasmaßes:
Einbauhöhe - 12 mm = Glasmaß

Material/Oberfläche KU = Kunststoff



KU1



KU2

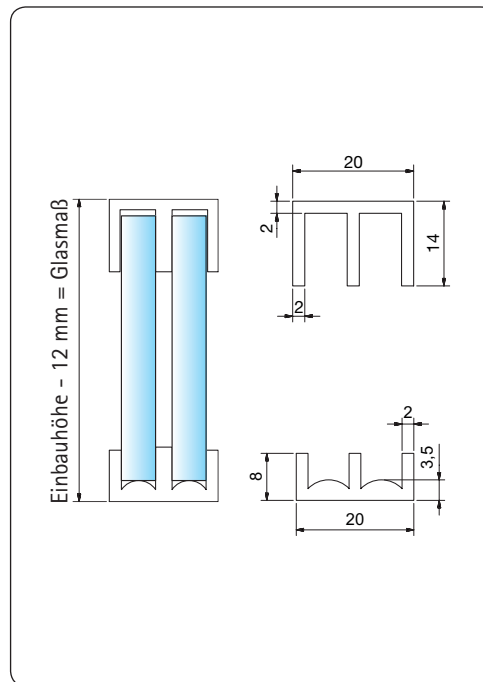

Art. Nr.: 2771

Obere Doppel-U-Führungsschiene

Plattendicke  6 mm

Art. Nr.: 2772

Untere Doppel-U-Gleitschiene

Plattendicke  6 mm

Berechnung des Glasmaßes:
Einbauhöhe - 12 mm = Glasmaß

Material/Oberfläche KU = Kunststoff



KU2

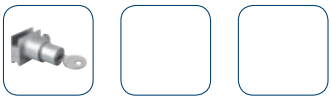

Zubehör

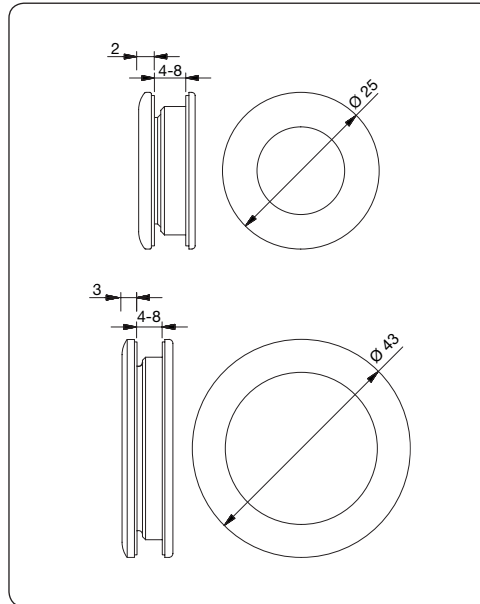
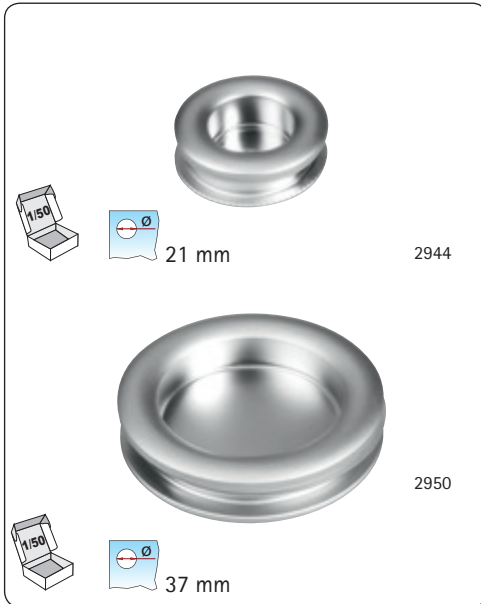

Art. Nr.: 2944

Einlassgriff zum Schrauben

Glasbohrung: \varnothing 21 mm

Plattendicke  4-8 mm

Art. Nr.: 2950

Einlaßgriff zum Schrauben

Glasbohrung: \varnothing 37 mm

Plattendicke  4-8 mm

Material/Oberfläche E = Aluminium



E3/1



E3/5

Glasschiebetür-
beschläge

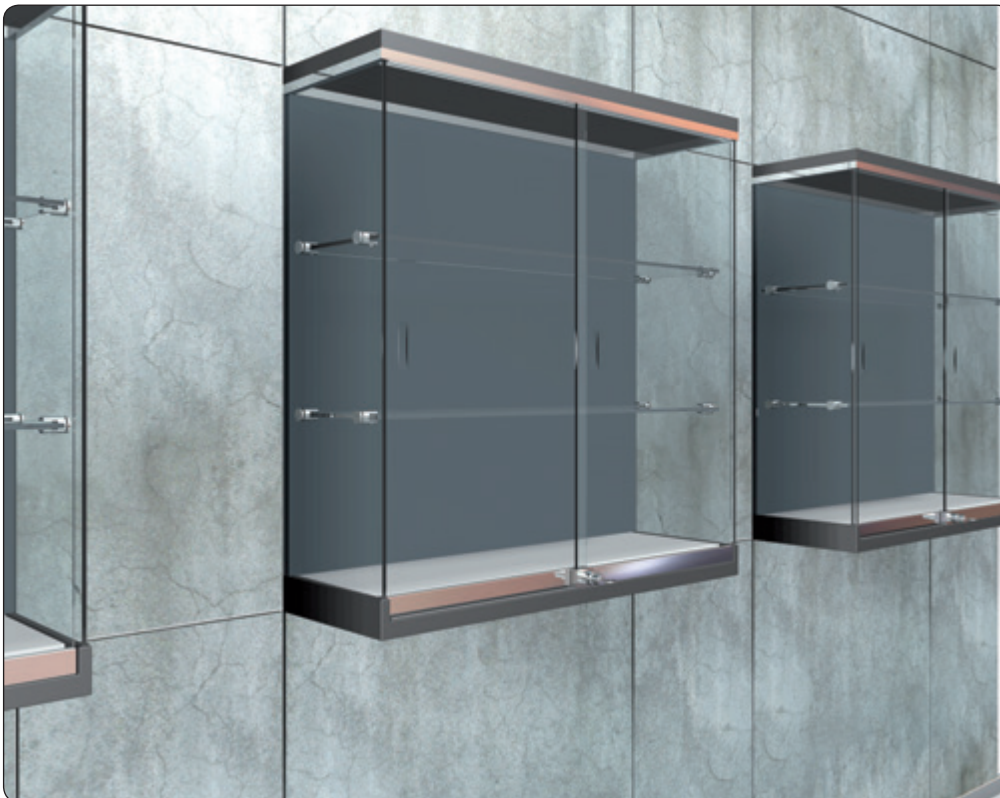



Zubehör

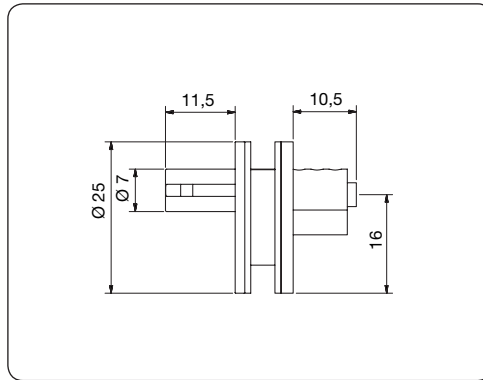
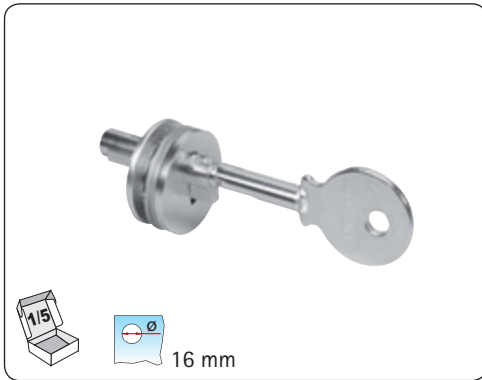

Art. Nr.: 2922

Glasschiebetürschloß mit zwei Schlüsseln und Zylindersperrerr

2922-G gleichschließend

2922-V verschiedenschließend

Glasbohrung: Ø 16 mm

Plattendicke 6 mm

Material/Oberfläche KU = Kunststoff



KU6

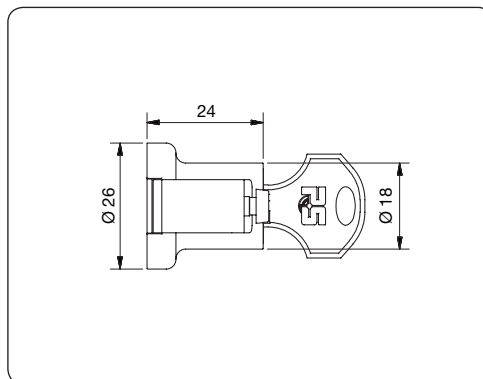
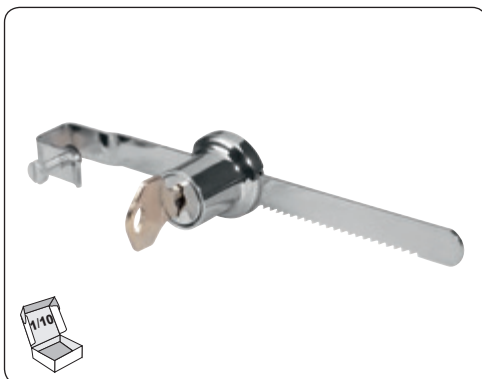

Art. Nr.: 2930

Glasschiebetürschloß mit Zahnstange 125 mm lang zum Aufklemmen, zwei Schlüssel

2930-G gleichschließend

2930-V verschiedenschließend

Plattendicke 2-8 mm

Material/Oberfläche ZN = Zink



ZN3

Glasschiebetür-
beschläge



Zubehör

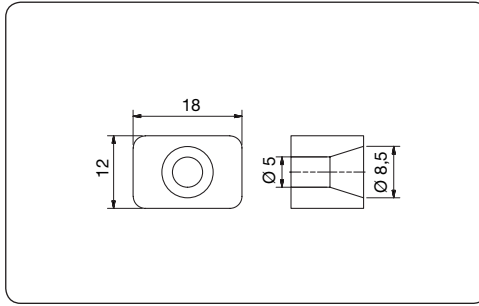
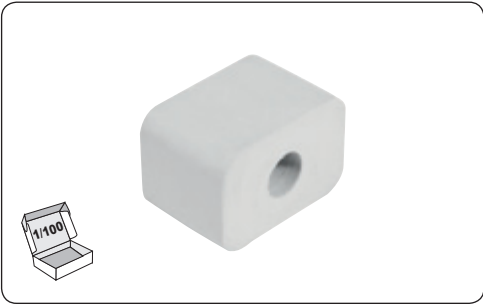

Art. Nr.: 2970

Gummipuffer zum Anschrauben

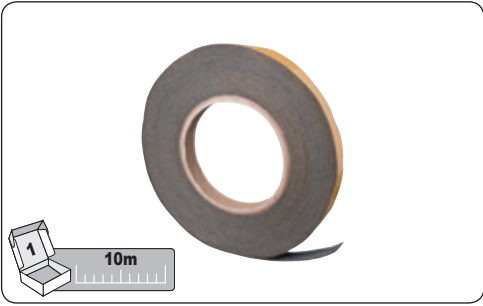

Art. Nr.: 2972

Filzstreifen, selbstklebend

Anwendungen Klapperschutz etc.

Abmessung 13 mm x 1,5 mm

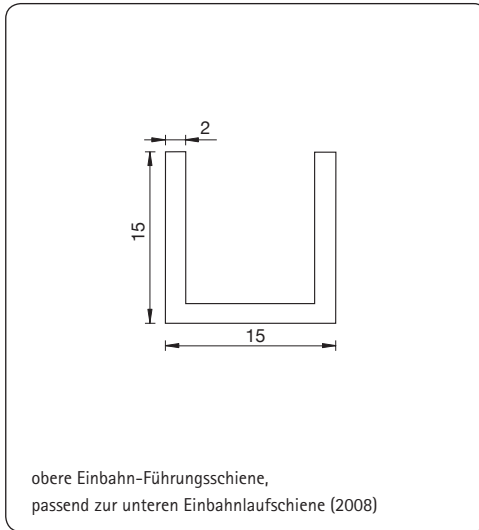

obere Einbahn-Führungsschiene,
passend zur unteren Einbahnlaufschiene (2008)

Art. Nr.: 5015

U-Profil 15 x 15 x 5000 x 2 mm

Plattendicke  ≤ 11 mm

Art. Nr.: 5016

U-Profil 15 x 15 x 5000 x 2 mm

samtiert für ruhigen Lauf

Plattendicke  ≤ 11 mm

Material/Oberfläche E = Aluminium



E6/EV1

Glasschiebetür-
beschläge



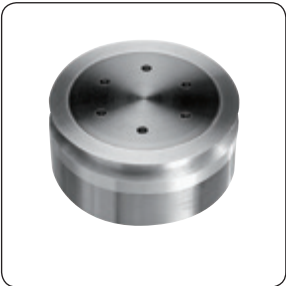

■ Punkthalter



■ Inhalt

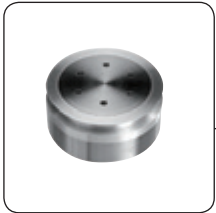

| | |
|---|-----|
| ■ Punkthalter erhaben | 132 |
| Punkthalter flächenbündig für Lichtdecken | 150 |
| Punkthalter flächenbündig | 154 |
| Zubehör | 164 |
| Befestigungswinkel | 166 |
| Punkthalter – Unbegrenzte Möglichkeiten | 168 |

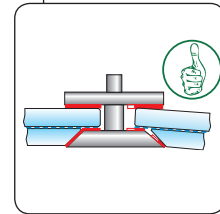
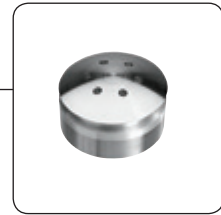

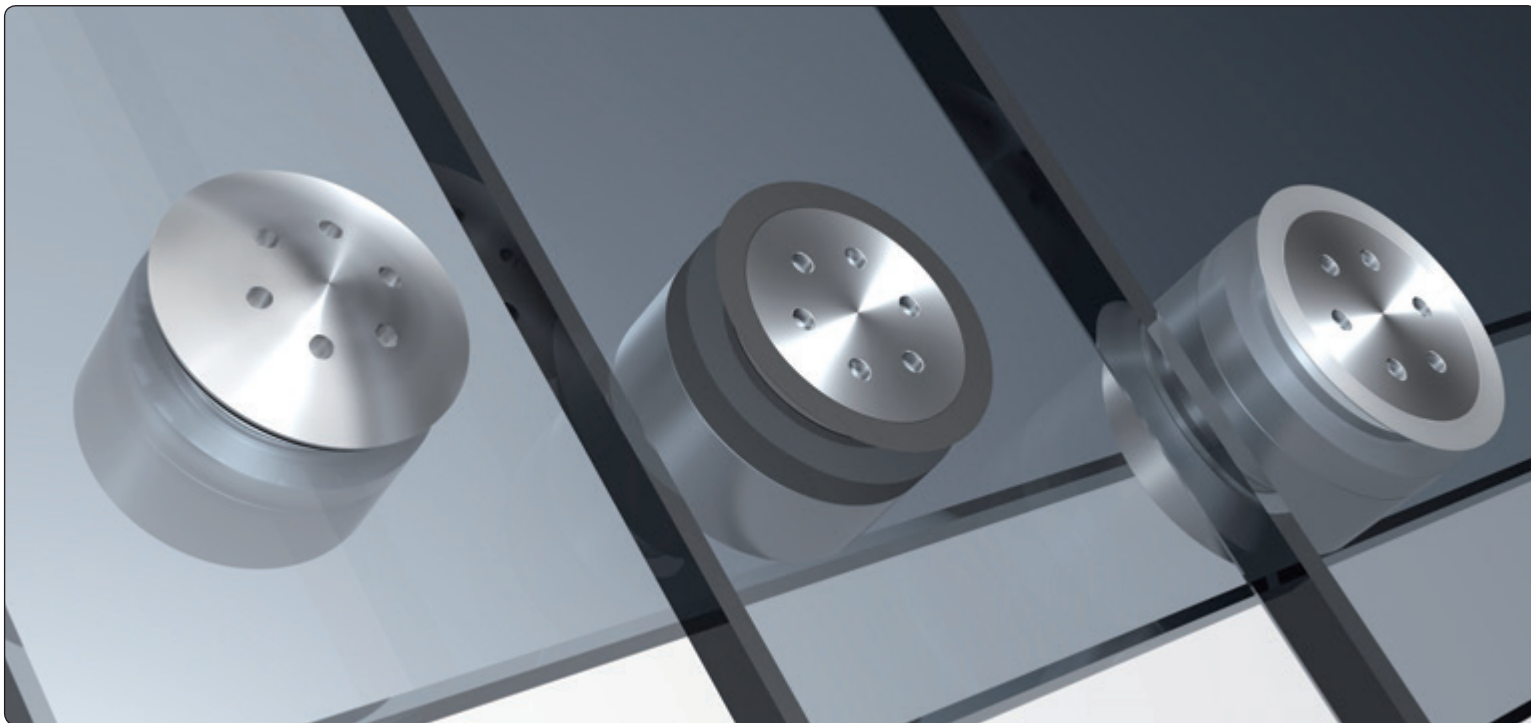



■ Kurzbezeichnungen für Material- und Ausführungsarten

ZN = Zink

 ZN0 = roh

 ZN1 = mattverchromt

 ZN5 = glanzverchromt

 ZN12 = Alu-Optik

 ZN22 = Edelstahloptik

 ZN22-K = Edelstahloptik mit Klarlack

 RAL = RAL Farben

VA = Edelstahl

 VA = Oberfläche geschlichtet

 VA1 = Poliert

 VA2 = Matt gebürstet

E = Aluminium

 E0 = roh

 E6/EV1 = Alu-Optik (silberfarbig eloxiert)

MS = Messing

 MS7 = glanzverchromt



- Punkthalter erhaben

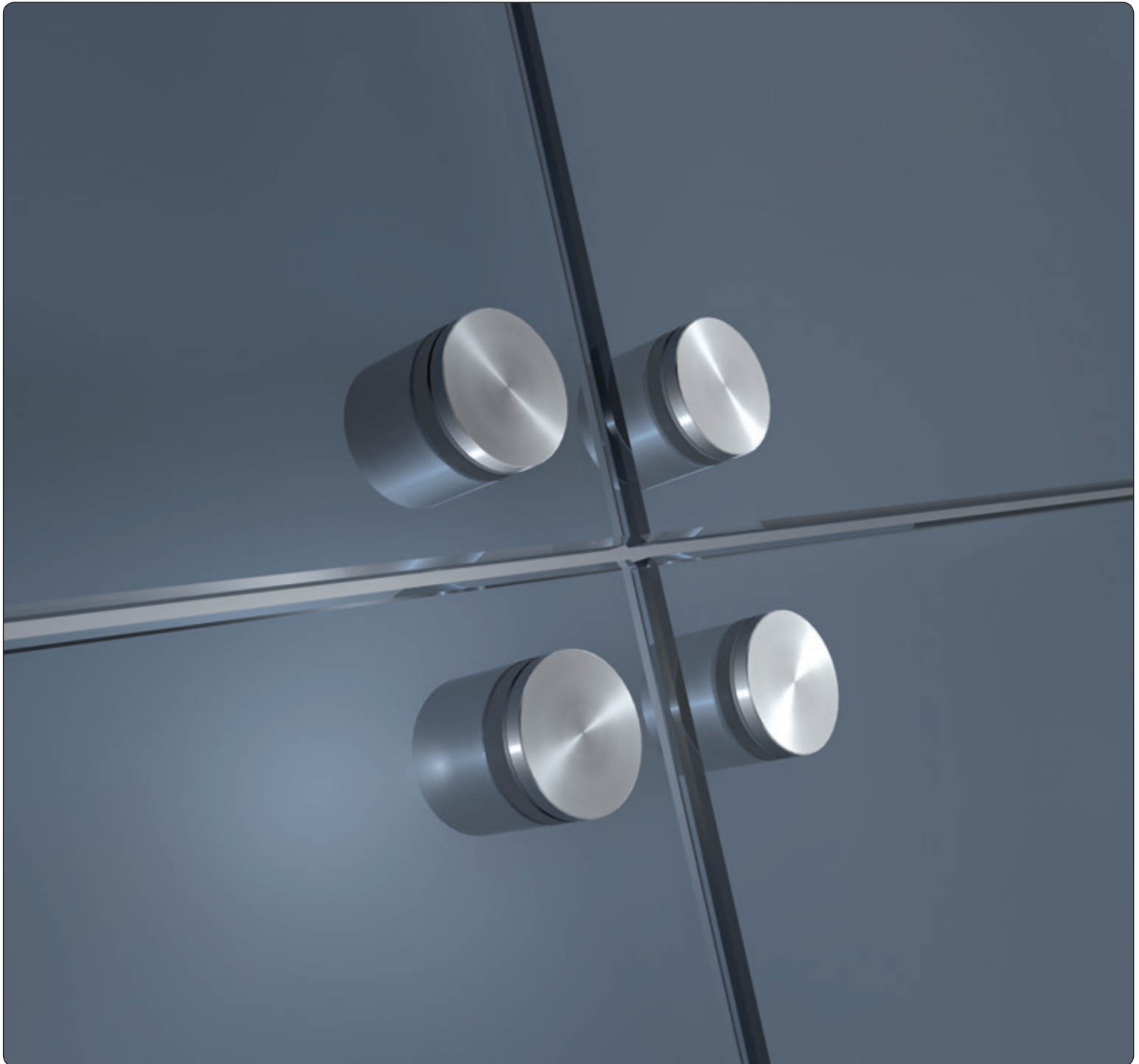



■ Punkthalter erhaben

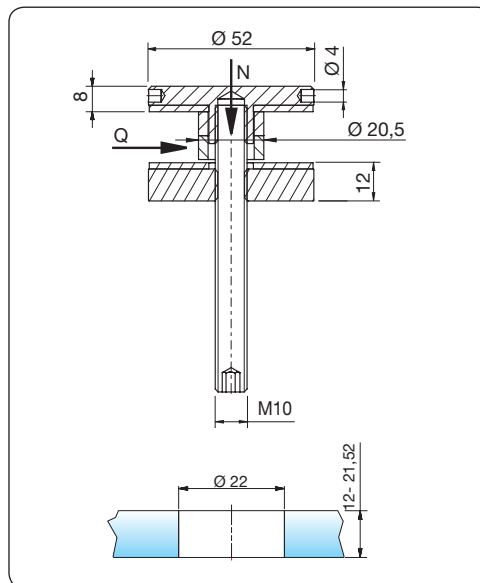

Art. Nr.: 7072

Punkthalter Ø 52 mm

Belastungswerte:
maxN= 6,0 kN, maxQ = 4,0 kN

Plattendicke 12-21,52 mm

Material A2, A4

Oberfläche VA = Edelstahl



VA

inklusive
 DIN913 M10 x 90 mm

Zubehör
 Z060

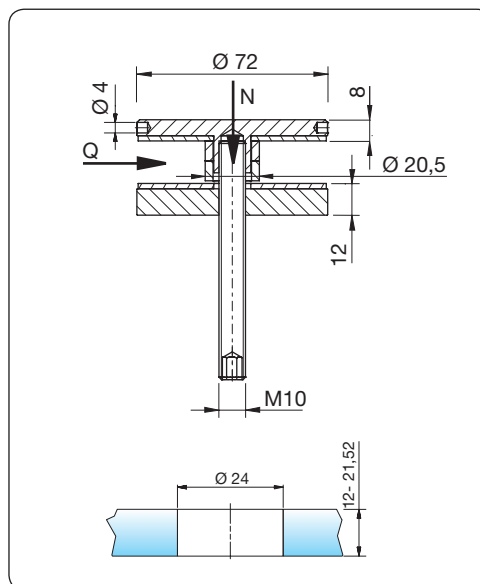

Art. Nr.: 7073

Punkthalter Ø 72 mm

Belastungswerte:
maxN= 6,0 kN, maxQ = 4,0 kN

Plattendicke 12-21,52 mm

Material/Oberfläche VA = Edelstahl (A2)



VA

inklusive
 DIN913 M10 x 90 mm

Zubehör
 Z060

Informationen

Ausführliche Informationen zu Produkten und sicherheitsrelevanten Vorgaben für die Verbauung von Brüstungen erhalten Sie in den Brüstungswelten.





■ Punkthalter erhaben

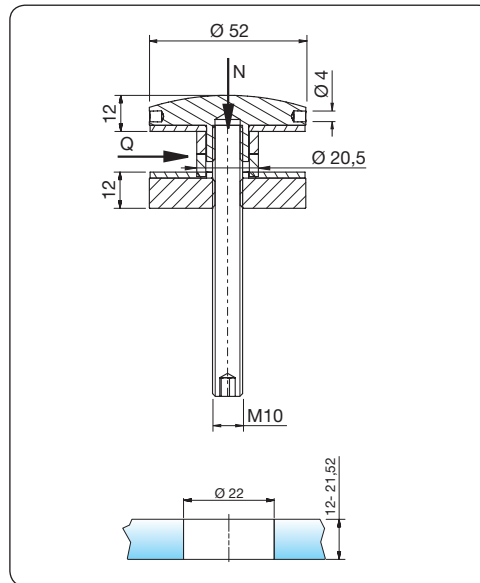

Art. Nr.: 7076

Punkthalter Ø 52 mm

Belastungswerte:
maxN= 6,0 kN, maxQ = 4,0 kN

Plattendicke  12-21,52 mm

Material/Oberfläche VA = Edelstahl (A2)



VA

inklusive
 DIN913 M10 x 90 mm

Zubehör
 Z060

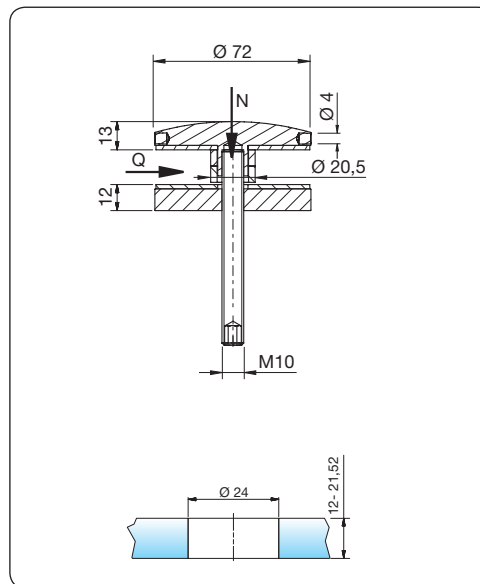

Art. Nr.: 7077

Punkthalter Ø 72 mm

Belastungswerte:
maxN= 6,0 kN, maxQ = 4,0 kN

Plattendicke  12-21,52 mm

Material/Oberfläche VA = Edelstahl (A2)



VA

inklusive
 DIN913 M10 x 90 mm

Zubehör
 Z060

Informationen

TRPV = Mit TRPV (Technische Regeln für Bemessung und Ausführung punktförmig gelagerter Verglasungen) gekennzeichnete Produkte entsprechen dieser eingeführten Vorschrift. Ausführliche Informationen finden Sie in den Glasdachwelten.

TRAV = Die TRAV (Technischen Regeln für die Verwendung von absturzsichernden Verglasungen) regeln die Verbauung von Absturzsicherungen (Balkone, Geländer). Die Befestigung der Glasfüllungen erfolgt über Punkthalter mit verschiedenen Tellerdurchmessern. Die DIN 18008-4 oder alternativ die DIN 18008 soll in Zukunft die TRAV ersetzen. Ausführliche Informationen finden Sie in den Brüstungswelten.





■ Punkthalter erhaben

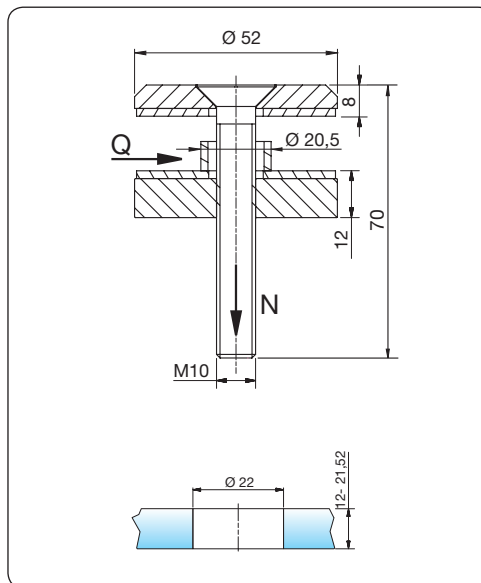

Art. Nr.: 7078

Punkthalter Ø 52 mm

Belastungswerte:
maxN= 6,0 kN, maxQ = 4,0 kN

Plattendicke  12-21,52 mm

Material/Oberfläche VA = Edelstahl (A2)



VA

inklusive
 DIN7991* M10 x 70 mm

* Schraubengewinde bis zum Kopf

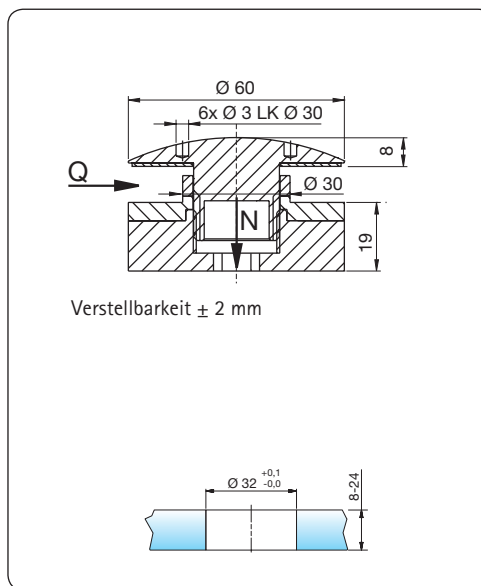

Art. Nr.: 7016

Punkthalter Ø 60 mm

Belastungswerte:
max. N: 6,0 kN, max. Q: 4,0 kN

Material/Oberfläche VA = Edelstahl (A2)

Plattendicke
7016VA  8 - 12 mm



7016VA-16  12 - 16 mm

7016VA-20  16 - 20 mm

7016VA-24  20 - 24 mm



VA

Zubehör
 Z058  M8

Informationen

Ausführliche Informationen zu Produkten und sicherheitsrelevanten Vorgaben für die Verbauung von Brüstungen erhalten Sie in den Brüstungswelten.



Punkthalter



■ Punkthalter erhaben

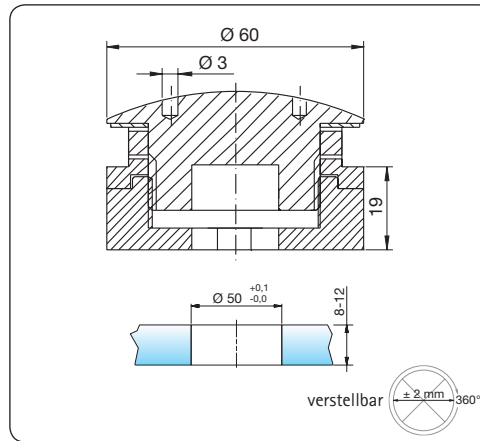
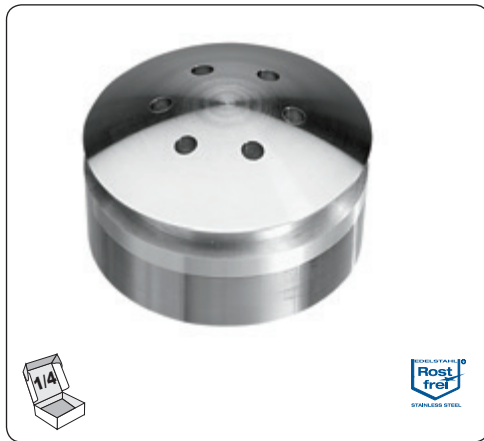

Art. Nr.: 7015

Punkthalter $\varnothing 60$ mm
mit Aluminium-Zentrierring

Belastungswerte: maxN = 10 kN, maxQ = 7,5 kN

Plattendicke  8-12 mm

Material/Oberfläche VA = Edelstahl (A2)



VA



Z058



M8

Zubehör

Art. Nr.: 7004

Punkthalter $\varnothing 40$ mit Aluminium-Zentrierring
Belastungswerte: maxN = 10 kN, maxQ = 7,5 kN

Plattendicke
7004VA  8-12 mm

7004VA-16  12-16 mm

7004VA-20  16-20 mm

7004VA-24  20-24 mm

Material/Oberfläche VA = Edelstahl (A2)



VA



Z058



M8

Zubehör

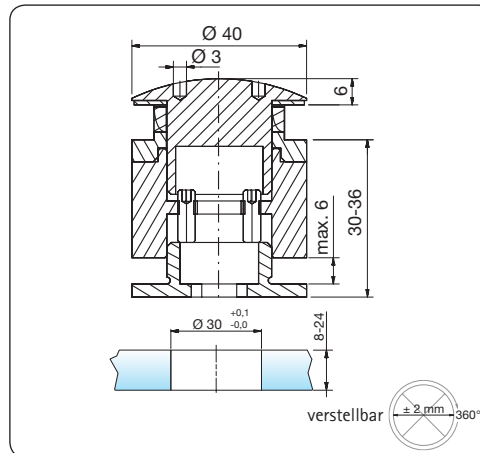

Art. Nr.: 7005

Punkthalter $\varnothing 40$ mit Aluminium-Zentrierring
Belastungswerte: maxN = 10 kN, maxQ = 7,5 kN

Plattendicke
7005VA  8-12 mm

7005VA-16  12-16 mm

7005VA-20  16-20 mm

7005VA-24  20-24 mm

Material/Oberfläche VA = Edelstahl (A2)



VA



Z058



M8

Zubehör



■ Punkthalter erhaben

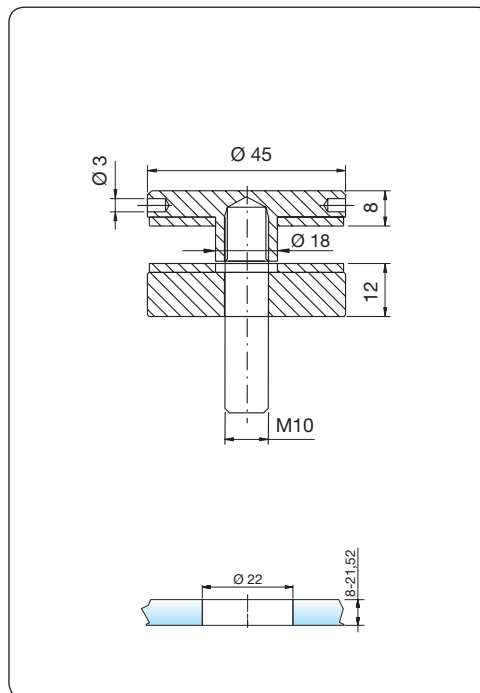

Art. Nr.: 7070, 7071

Punkthalter Ø 45 mm

Plattendicke
7070VA 8-21,52 mm

7071VA 8-21,52 mm

Belastungswerte:
maxN = 6,0 kN, maxQ = 4,0 kN



Plattendicke  8-21,52 mm

Material/Oberfläche VA = Edelstahl (A2)



VA

Inklusive

-  bei 7070VA
M10 x 50 mm
-  bei 7071VA, 10 x 100 mm
(Stockschraube)



Zubehör

Z060

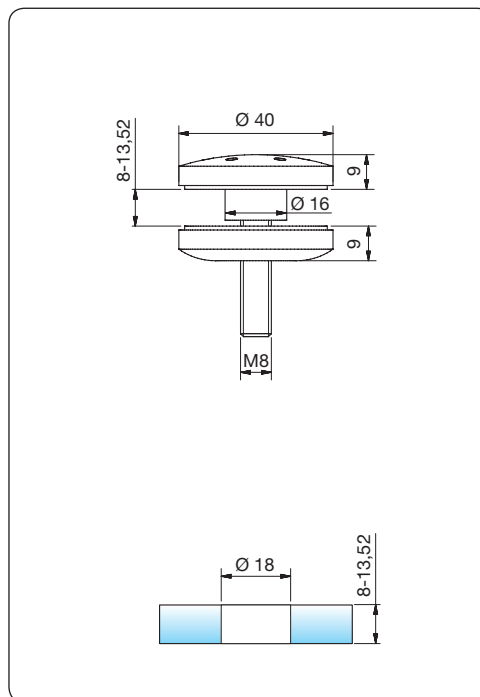

Art. Nr.: 1342-M8

Punkthalter Ø 40 mm

Belastungswerte:
in Bearbeitung

Plattendicke  8-13,52 mm

Material/Oberfläche VA = Edelstahl (A2)



VA

Inklusive

-  DIN913 M8 x 45 mm



Zubehör

Z058



■ Punkthalter erhaben

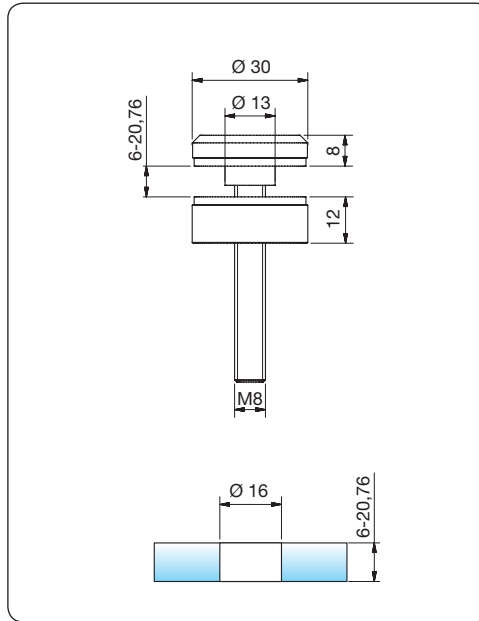

Art. Nr.: 1341-M8

Punkthalter Ø 30 mm

Belastungswerte: maxQ = 1,0 kN

Plattendicke 6-20,76 mm

Material/Oberfläche VA = Edelstahl (A2)



VA



Zubehör

Z057



M8 x 60 mm

Inklusive

8 x 60 mm
(Stockschraube)*

* max. Plattendicke ist zu prüfen

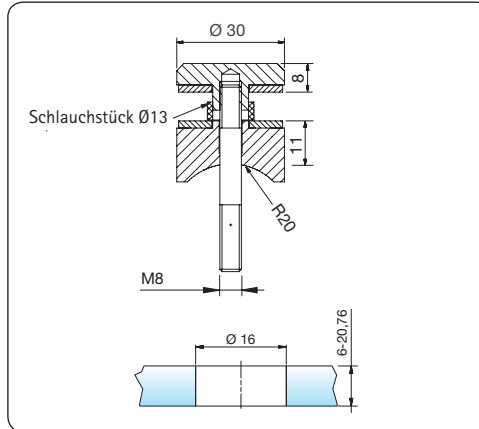

Art. Nr.: 1339-M8

Punkthalter Ø 30 mm

Belastungswerte: maxQ = 1,0 kN

Plattendicke 6-20,76 mm

Material/Oberfläche VA = Edelstahl (A2)



VA



M8 x 60 mm

Inklusive

8 x 60 mm
(Stockschraube)*



Zubehör

Z057

* max. Plattendicke ist zu prüfen



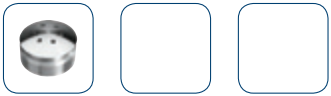

■ Punkthalter erhaben

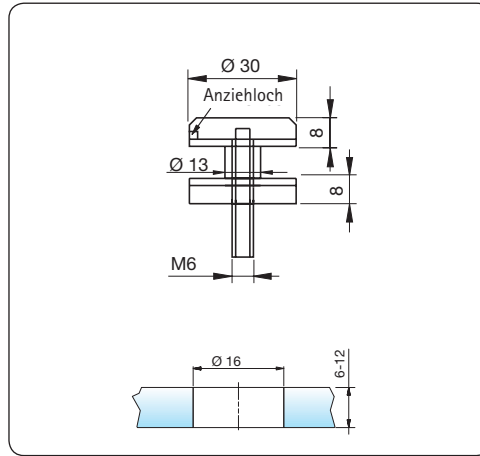

Art. Nr.: 4870, 4872

Punkthalter Ø 30 mm

Belastungswerte: maxQ = 1,0 kN

Plattendicke 6-12 mm

Material/Oberfläche ZN = Zink



Inklusive

- bei 4870 M6 x 60 mm
- bei 4872 6 x 60 mm (Stockschraube)*

Zubehör

Z057

* max. Plattendicke ist zu prüfen

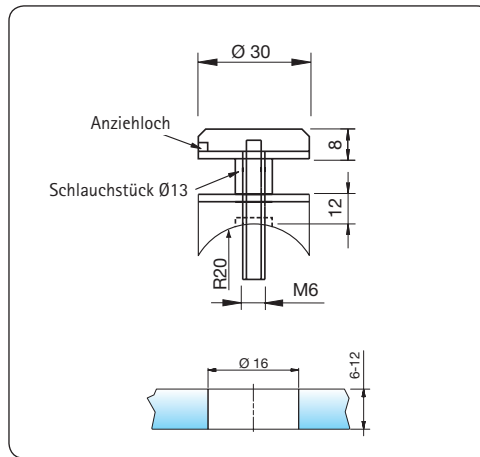

Art. Nr.: 4871

Punkthalter Ø 30 mm

Belastungswerte: maxQ = 1,0 kN

Plattendicke 6-12 mm

Material/Oberfläche ZN = Zink



Inklusive

- M6 x 60 mm

Zubehör

Z057



Punkthalter



■ Punkthalter erhaben

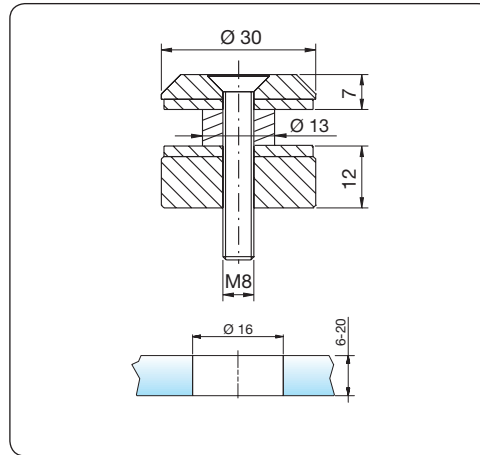

Art. Nr.: 7082VA-M8

Punkthalter Ø 30 mm

Belastungswerte: maxQ = 1,0 kN

Plattendicke 6-20 mm

Material/Oberfläche VA = Edelstahl (A2)



VA

Inklusive

- M8 x 45 mm
- 8 x 50 mm

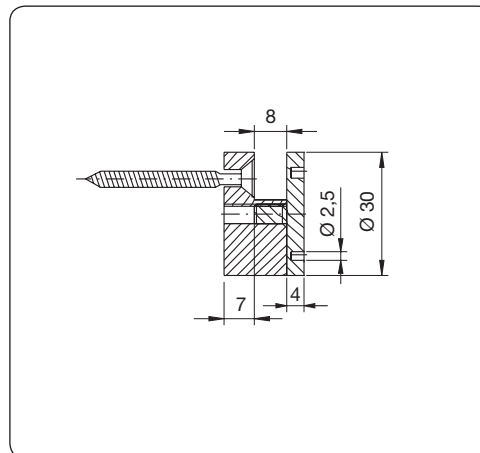

Art. Nr.: 7100

Punkthalter Ø 30 mm

Plattendicke 8 mm

Material/Oberfläche E = Aluminium



E0

Inklusive

- Ø 4,5 x 60 mm

Zubehör

- Z059

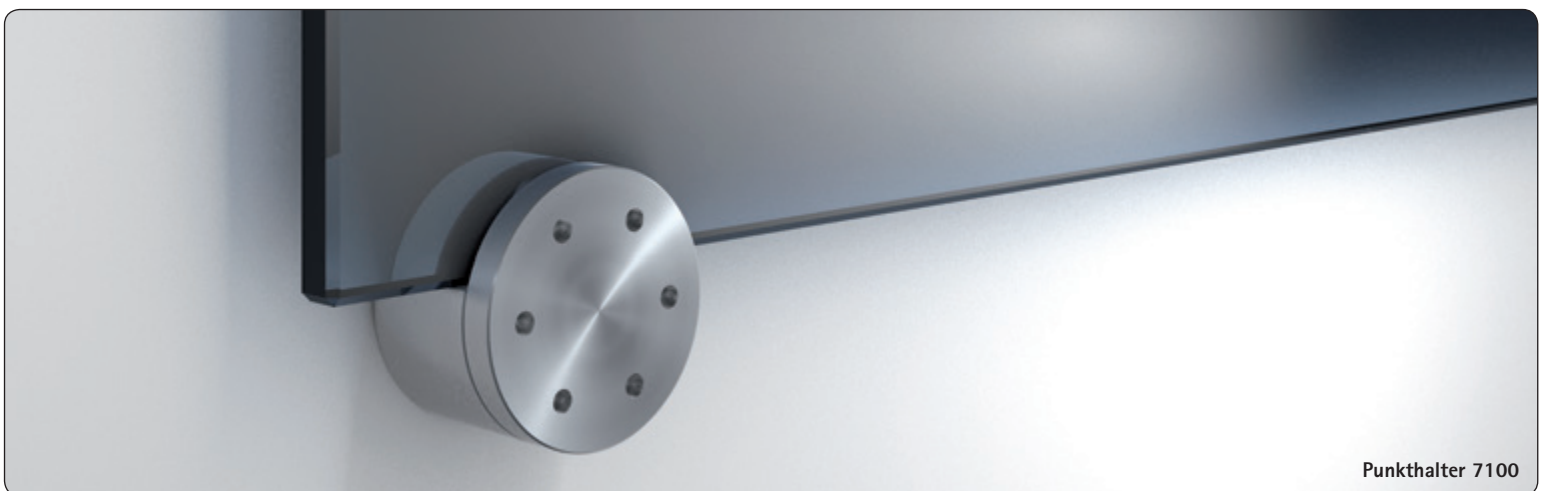

Punkthalter 7100



■ Punkthalter erhaben

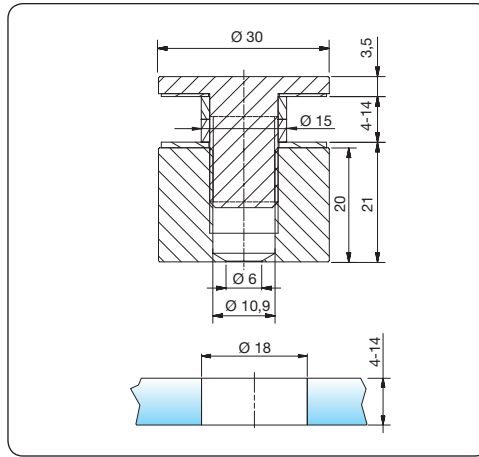

Art. Nr.: 7064

Punkthalter Ø 30 mm

Belastungswerte: maxQ = 2,0 kN

Plattendicke  4-14 mm

Material/Oberfläche VA = Edelstahl (A2)



VA

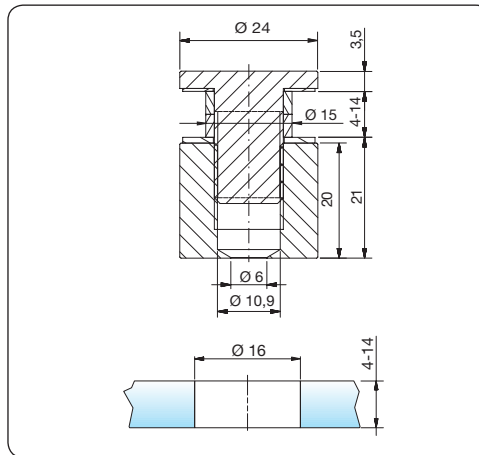
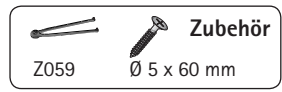

Art. Nr.: 7063

Punkthalter Ø 24 mm

Belastungswerte: maxQ = 2,0 kN

Plattendicke  4-14 mm

Material/Oberfläche VA = Edelstahl (A2)



VA

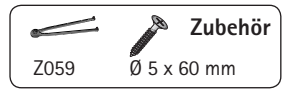



■ Punkthalter erhaben

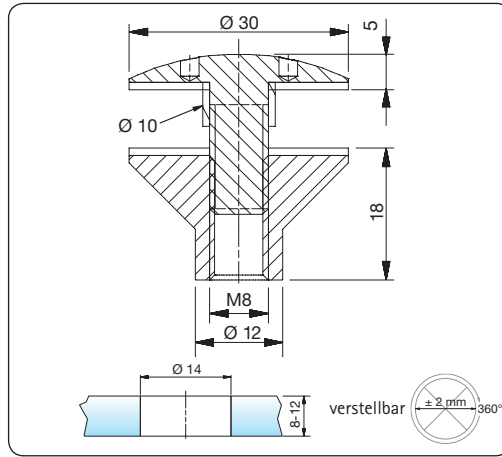

Art. Nr.: 7713

Punkthalter mit M8-Anschluss Ø 30 mm

Plattendicke 8-12 mm

Material/Oberfläche VA = Edelstahl (A2)



VA



Z059

Zubehör

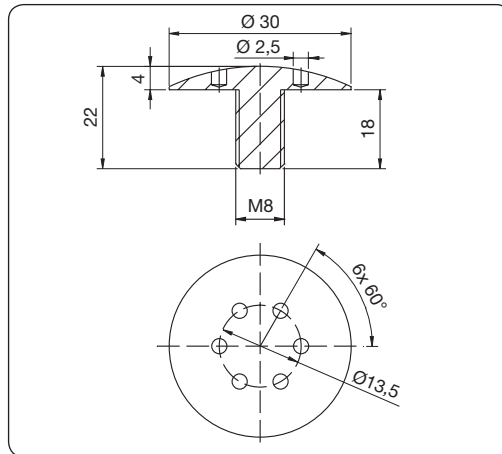

Art. Nr.: 7700-27

Punkthalterkopf mit M8 Ø 30 mm

Material/Oberfläche VA = Edelstahl (A2)



VA



Z059

Zubehör



■ Punkthalter erhaben

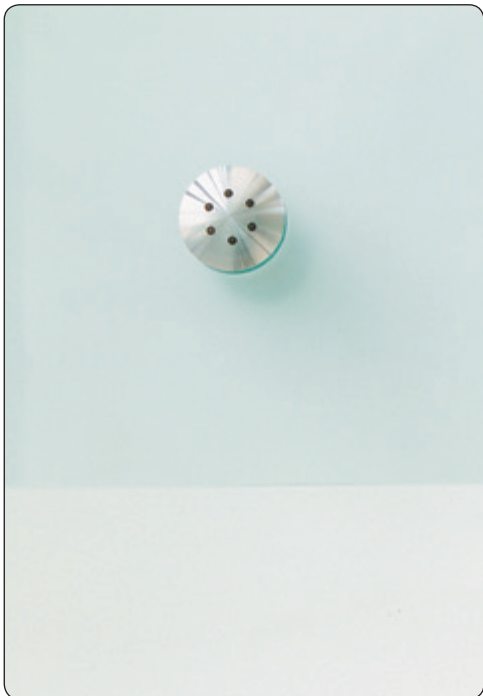

Punkthalter



■ Punkthalter erhaben

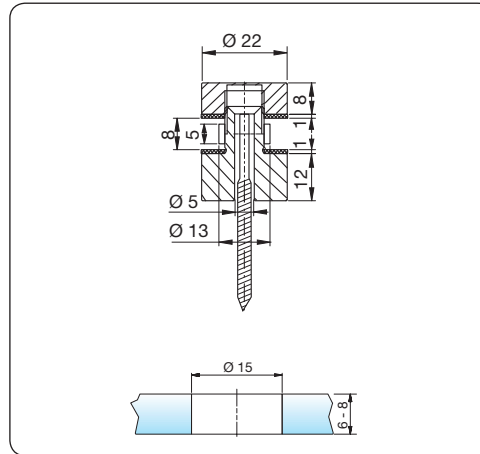

Art. Nr.: 7120

Punkthalter Ø 22 mm

Belastungswerte: maxQ = 1,0 kN

Plattendicke 6-8 mm

Material/Oberfläche VA = Edelstahl (A2)



VA



Ø 4,5 x 60 mm

Inklusive

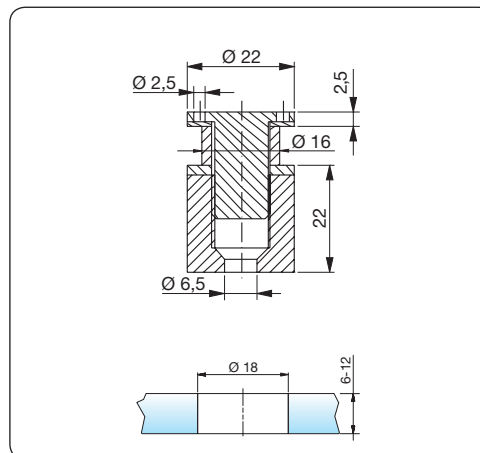

Art. Nr.: 7061

Punkthalter Ø 22 mm

Belastungswerte: maxQ = 2,0 kN

Plattendicke 6-12 mm

Material/Oberfläche VA = Edelstahl (A2)



VA



Z059



Ø 5 x 60 mm

Zubehör





■ Punkthalter erhaben

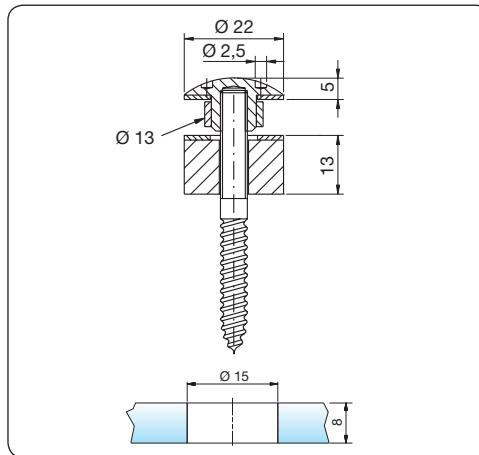

Art. Nr.: 7110

Punkthalter Ø 22 mm

Belastungswerte: maxQ = 0,5 kN

Plattendicke 8 mm

Material/Oberfläche VA = Edelstahl (A2)



VA

Inklusive
6 x 60 mm (Stockschraube)

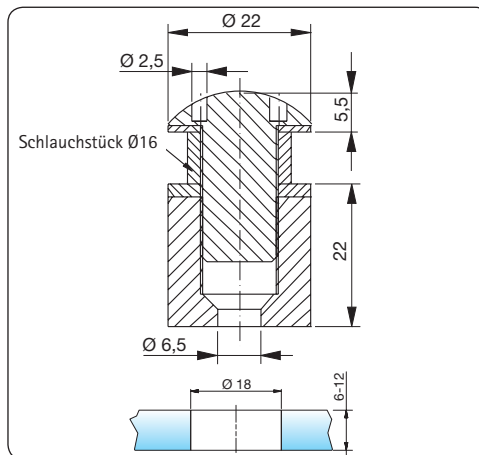

Art. Nr.: 7062

Punkthalter Ø 22 mm

Belastungswerte: maxQ = 2,0 kN

Plattendicke 6-12 mm

Material/Oberfläche VA = Edelstahl (A2)



VA

Zubehör
Z059 Ø 5 x 60 mm

Punkthalter



■ Punkthalter erhaben

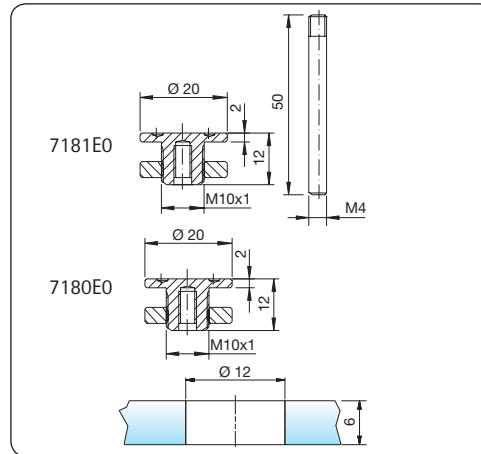

Art. Nr.: 7180, 7181

Punkthalter Ø 20 mm
 7180EO
 7181EO mit Gewindestift

Plattendicke 6 mm

Material/Oberfläche E = Aluminium

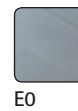

Inklusive
 bei 7181EO M4x50 mm

Zubehör
 Z059

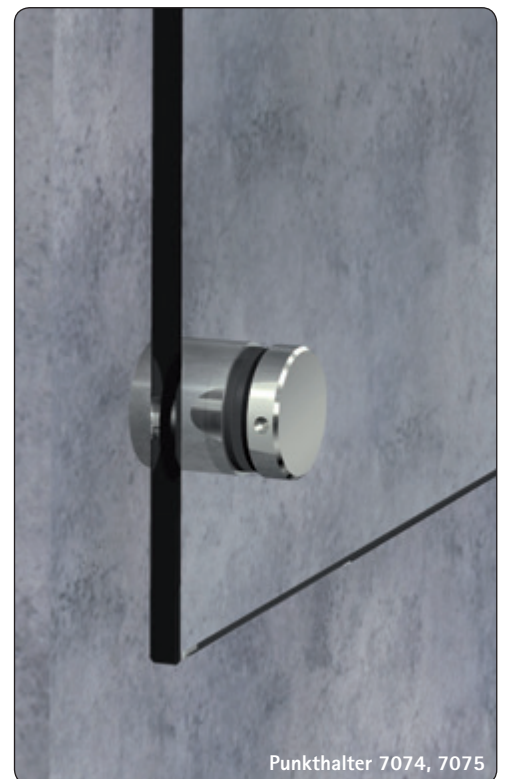
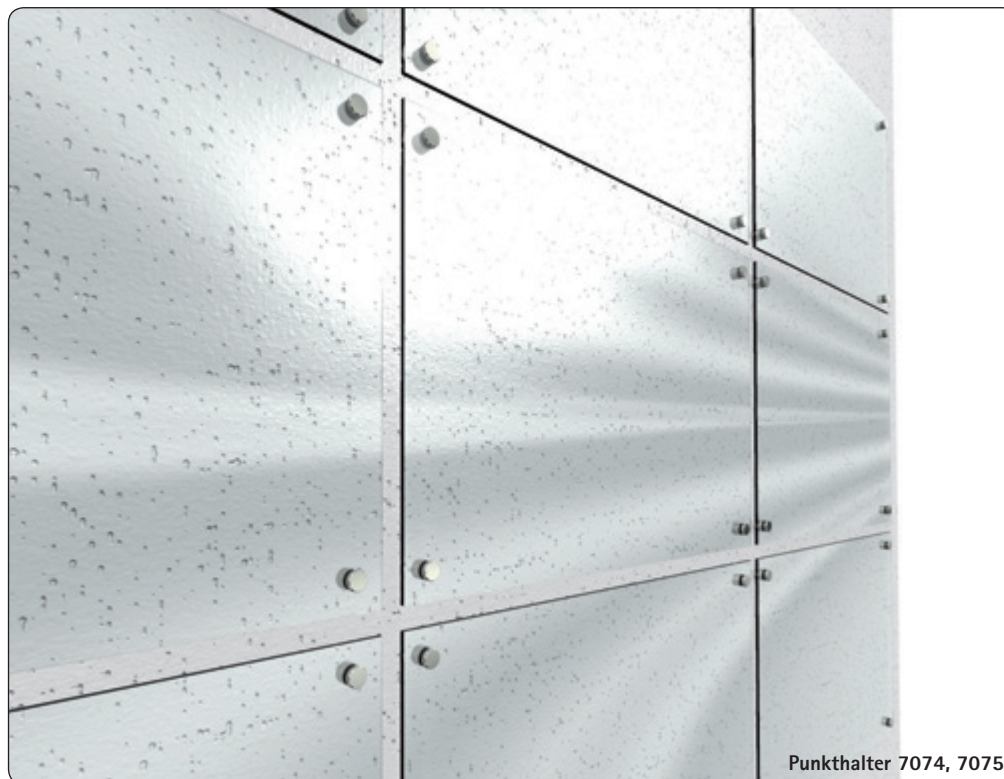



■ Punkthalter erhaben

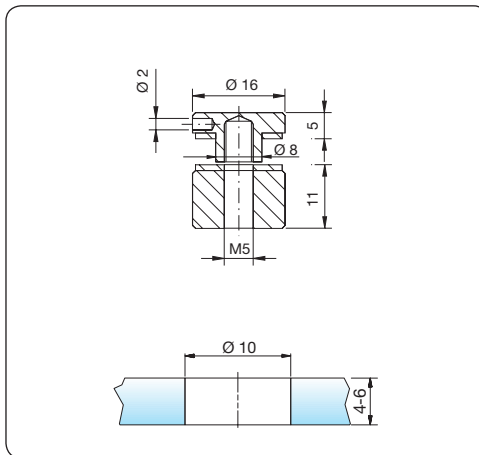

Art. Nr.: 7074, 7075

Punkthalter Ø 16 mm

Belastungswerte: maxQ = 0,25 kN

Plattendicke 4-6 mm

Material/Oberfläche VA = Edelstahl (A2)



VA

Inklusive

- bei 7074VA M5x40 mm
- bei 7075VA 5x40 mm (Stockschraube)

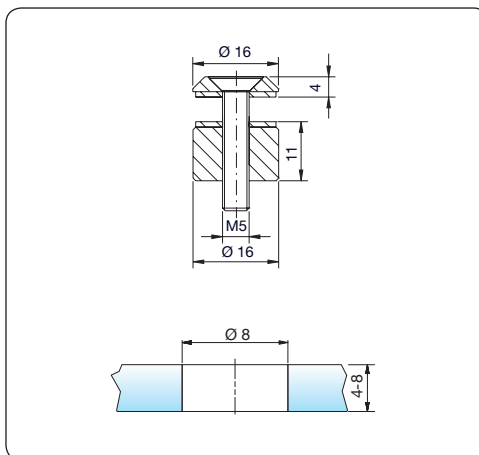
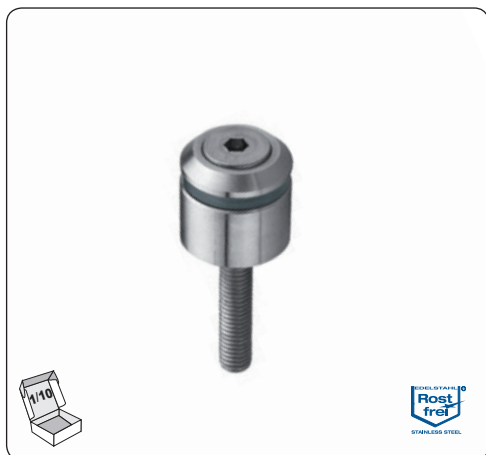

Art. Nr.: 7084, 7085

Punkthalter Ø 16 mm

Belastungswerte: maxQ = 0,25 kN

Plattendicke 4-8 mm

Material/Oberfläche VA = Edelstahl (A2)



VA

Inklusive

- bei 7084VA
DIN 7991 M5x40 mm
- bei 7085VA 5x40 mm



■ Punkthalter erhaben

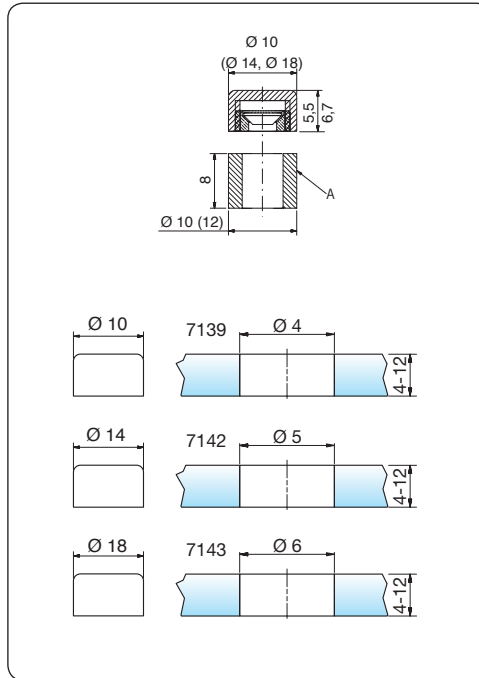

Art. Nr.: 7139, 7142, 7143

Punkthalter Ø 10/14/18 mm
Acryldistanzstück

7139E1EV1S8-4-12F Ø 10 mm

7139MS7S8-4-12F Ø 10 mm

7139VAS8-4-12F Ø 10 mm

7142E1EV1S8-4-12F Ø 12 mm

7142MS7S8-4-12F Ø 12 mm

7142VAS8-4-12F Ø 12 mm

7143E1EV1S8-4-12F Ø 12 mm

7143MS7S8-4-12F Ø 12 mm

7143VAS8-4-12F Ø 12 mm

Plattendicke  4-12 mm

Material/Oberfläche E = Aluminium
MS = Messing
VA = Edelstahl (A2)



E1/EV1 MS7 VA

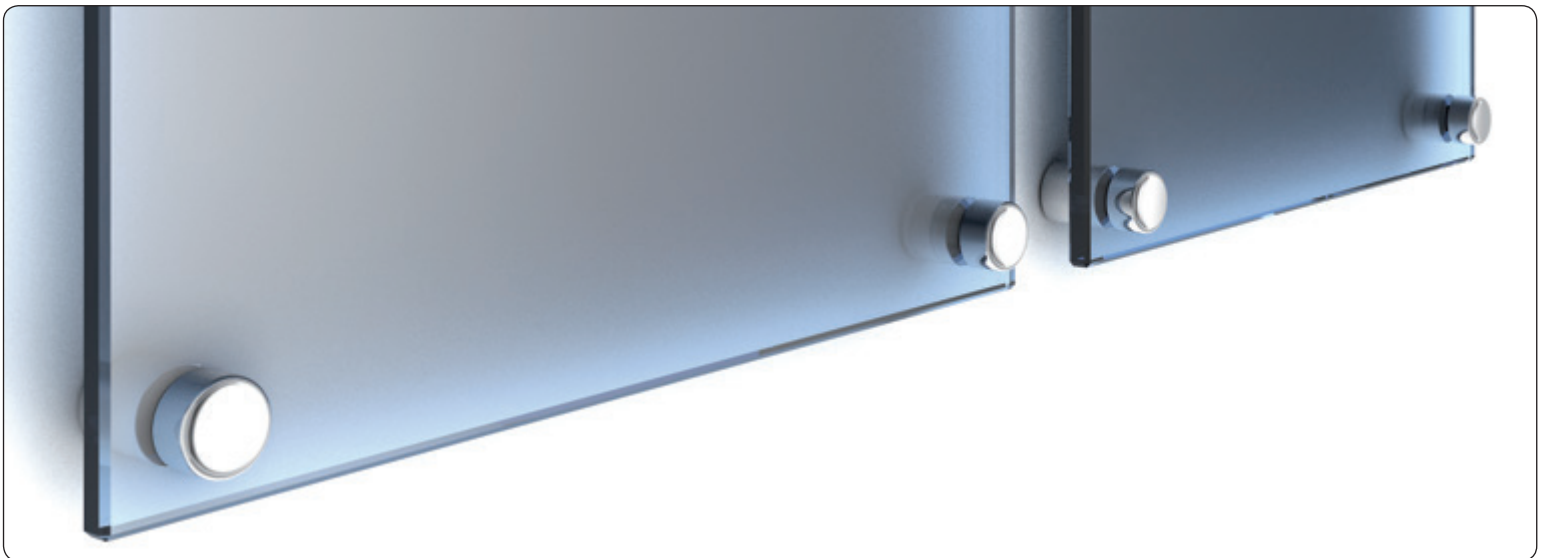



■ Punkthalter erhaben

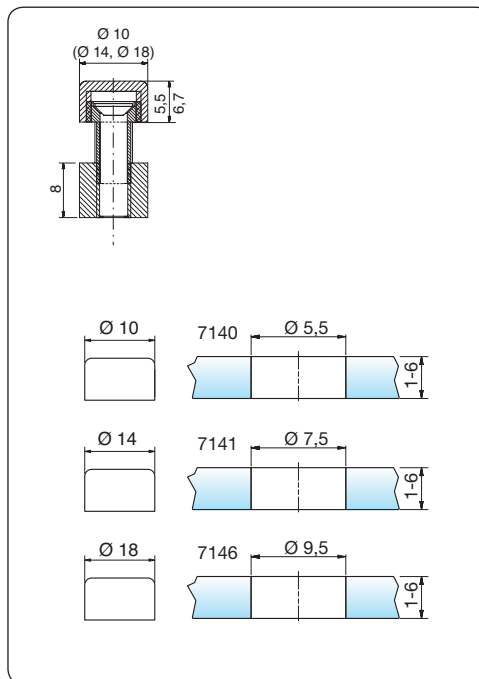

Art. Nr.: 7140, 7141, 7146

Punkthalter \varnothing 10/14/18 mm

7140E1EV1S8-6F

7140MS7S8-6F

7140VAS8-6F

7141E1EV1S8-6F

7141MS7S8-6F

7141VAS8-6F

7146E1EV1S8-6F

7146MS7S8-6F

7146VAS8-6F

Plattendicke  1-6 mm

Material/Oberfläche E = Aluminium
MS = Messing
VA = Edelstahl (A2)

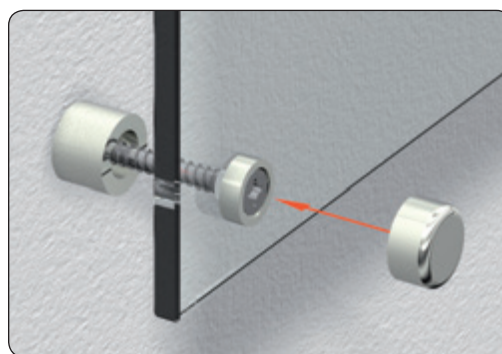
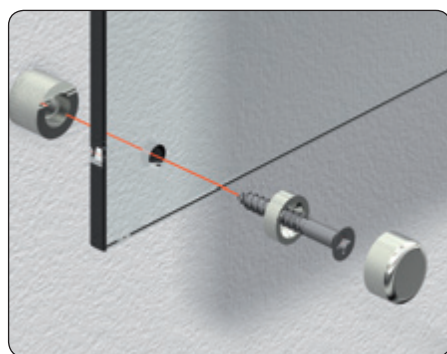
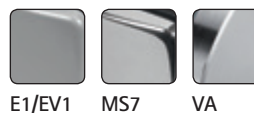



■ Punkthalter flächenbündig





■ Punkthalter flächenbündig

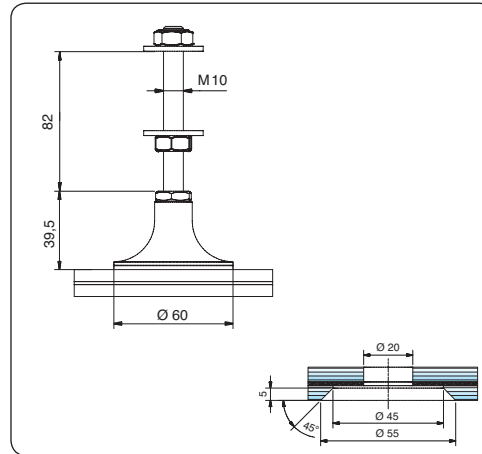

Art.-Nr.: 7590

Senkpunkthalter für Überkopfverglasung

Plattendicke 13,52 mm/17,52 mm/21,52 mm

Belastungswerte: in Bearbeitung

Material/Oberfläche VA = Edelstahl (A2)Hinweis

Glasherstellung:
Erst nach der Herstellung des VSG darf nur der Bereich der PVB-Folie Ø20mm ausgeschnitten werden.

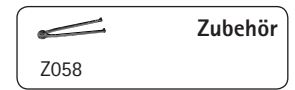

Lichtdecken mit Punkthaltern

Von oben beleuchtetes abgehängtes Glas hat seine ganz eigene Wirkung. Räume bekommen durch die rahmenlose Montage ein helles Wohlfühlklima. Mit unseren SSH-Haltern können Sie je nach Unterkonstruktion, Glasscheiben bis zu 1650 x 3300 mm befestigen.



- sehr gute Resttragfähigkeit durch Klemmung der oberen Glasscheibe inklusive der PVB-Folie
- zweite, untere Glasscheibe des VSG wird mit einer Senkung versehen.
- Resttragfähigkeit per Bauteilversuch nachgewiesen (ist von Bauaufsichten für Lichtdecken gefordert)
- geeignet auch für Überkopfverglasungen (siehe auch Glasdachwelten)





- Lichtdecken – Das ist erforderlich.



Die Lichtdecke ist eine sicherheitsrelevante Anwendung. Die zuständigen Bauaufsichten fordern folgende Nachweise:

- statische Berechnung infolge des Eigengewichtes und der Staublast (i. d. R. 20 kg/m^2 oder 30 kg/m^2)
- Nachweis der Resttragfähigkeit (unter Umständen durch Bauteilversuche)
- Oft ist sogar eine ZiE (Zustimmung im Einzelfall) erforderlich.

Wichtig sind hier natürlich die Konstruktionsdetails wie z.B. die Klemmfläche des Punkthalters und die Anbindung an die Unterkonstruktion. Pauli + Sohn bietet diverse Punkthalter an, die für Lichtdecken geeignet sind.



Belastungstest bestanden!



Besonders geeignet und formschön sind die SSH-Punkthalter mit ihrer Flächenbündigkeit.

Durch die spezielle Bohrungsgeometrie können SSH-Punkthalter auch im Überkopfbereich eingesetzt werden.

- Versuchsbericht zu den Belastungstests liegt vor
- jetzt mit Allgemeiner bauaufsichtlicher Zulassung
- Abmessungen bis 1878 x 3500 mm
- statische Berechnungen für ausgewählte Formate vorhanden

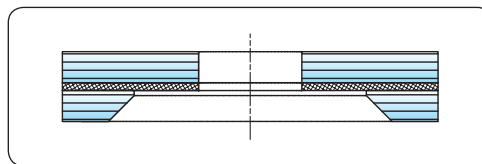

Punkthalter

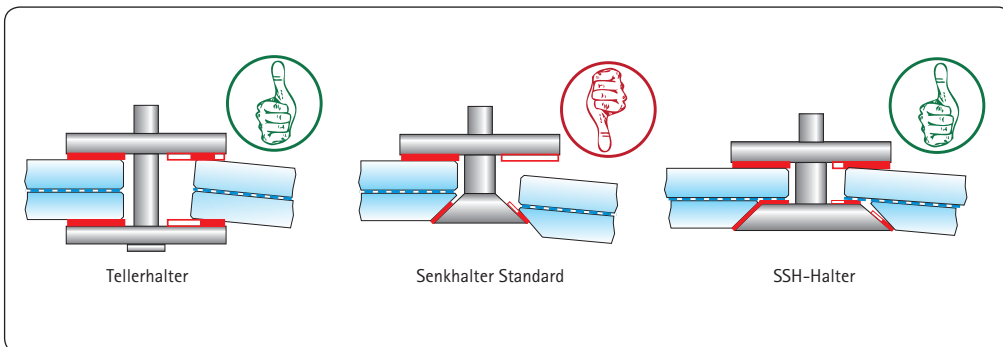

Informationen

Ausführliche Informationen zu Produkten und sicherheitsrelevanten Vorgaben für die Verbauung von Vordächern und Überkopfbverglastungen erhalten Sie in den Glasdachwellen.





■ Punkthalter flächenbündig





■ Punkthalter flächenbündig

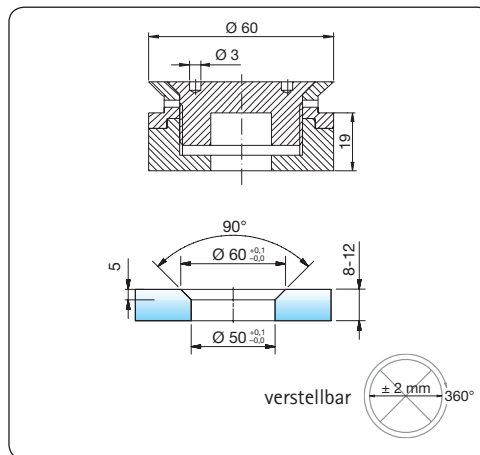
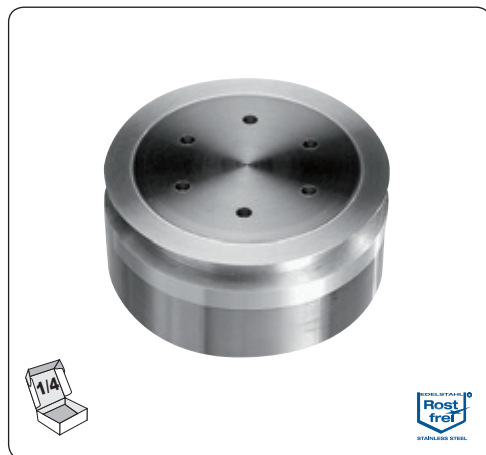

Art. Nr.: 7010

Punkthalter mit Aluminium-Senkbuchse und -Zentrierung Ø 60 mm

Belastungswerte: maxN = 10 kN, maxQ = 7,5 kN

Plattendicke 8-12 mm

Material/Oberfläche VA = Edelstahl (A2)



VA

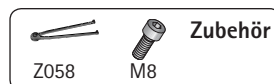

Z058

M8

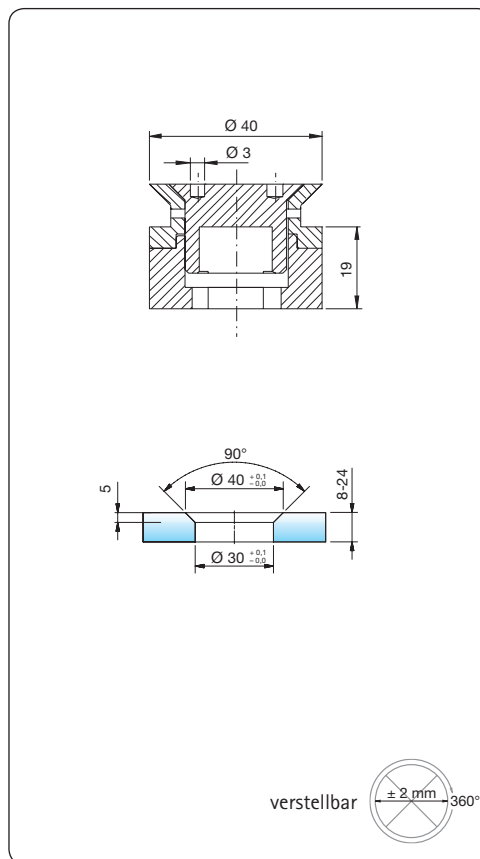

Art. Nr.: 7000

Punkthalter mit Aluminium-Senkbuchse und -Zentrierung Ø 40 mm

Belastungswerte: maxN = 10 kN, maxQ = 7,5 kN

Plattendicke
7000VA 8-12 mm

7000VA-16 12-16 mm

7000VA-20 16-20 mm

7000VA-24 20-24 mm

Art. Nr.: 7001

Punkthalter mit Kunststoff-Senkbuchse und Aluminium-Zentrierung Ø 40 mm

Belastungswerte: maxN = 10 kN, maxQ = 7,5 kN

Plattendicke
7001VA 8-12 mm

7001VA-16 12-16 mm

7001VA-20 16-20 mm

7001VA-24 20-24 mm

Material/Oberfläche VA = Edelstahl (A2)



VA

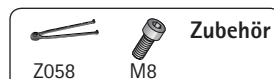

Z058

M8

Punkthalter



■ Punkthalter flächenbündig

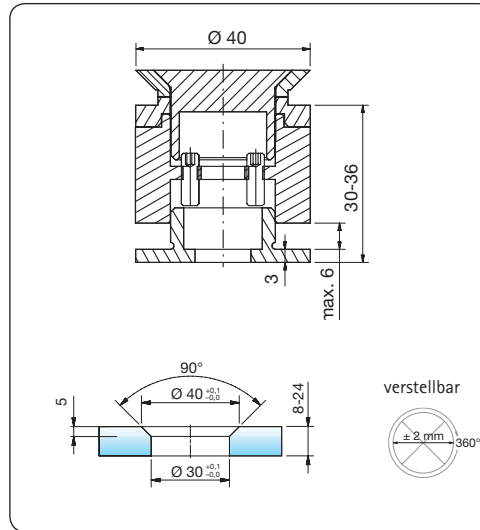

Art. Nr.: 7002

Punkthalter mit Aluminium-Senkbuchse und -Zentrierriering Ø 40 mm

Belastungswerte: in Bearbeitung

| | | |
|------------------------|--|----------|
| Plattendicke 7002VA | | 8-12 mm |
| 7002VA-16 | | 12-16 mm |
| 7002VA-20 | | 16-20 mm |
| 7002VA-24 | | 20-24 mm |

Material/Oberfläche VA = Edelstahl (A2)



VA

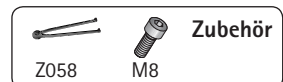

Zubehör

Z058

M8

Punkthalter

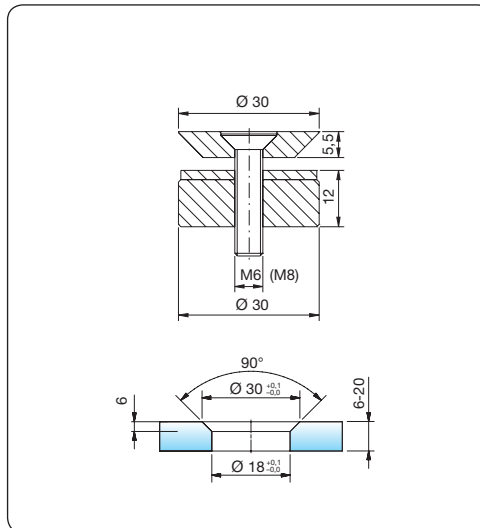
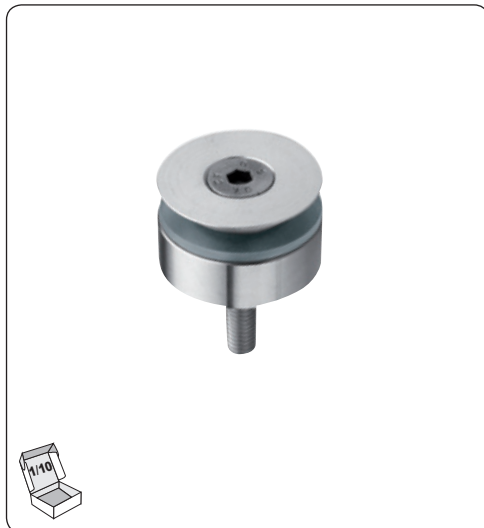

Art. Nr.: 7050

Punkthalter Ø 30 mm

Belastungswerte: maxQ = 1,0 kN

| | | |
|------------------------|--|---------|
| Plattendicke 7050E0 | | 6-15 mm |
| 7050E0-M8 | | 6-20 mm |
| 7051E0 | | 6-15 mm |

Material/Oberfläche E = Aluminium



E0

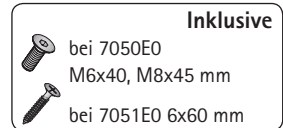

Inklusive

bei 7050E0
M6x40, M8x45 mm
bei 7051E0 6x60 mm



■ Punkthalter flächenbündig

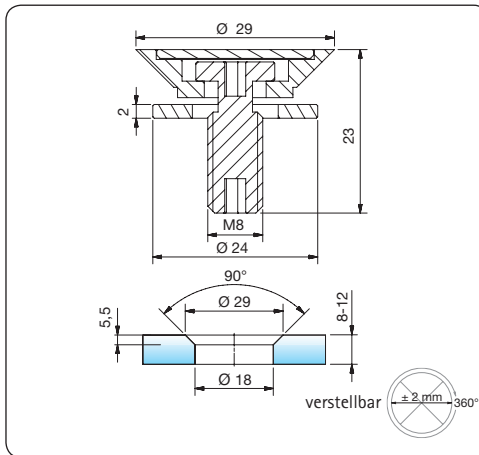
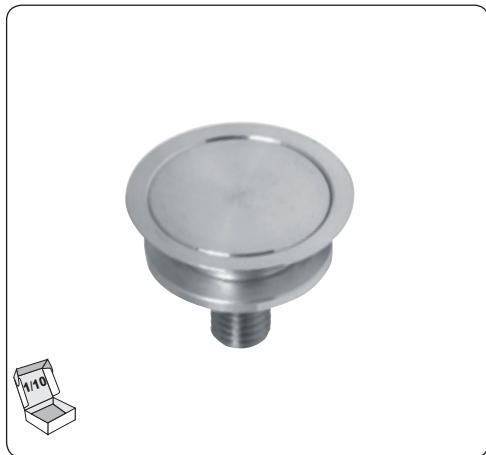

Art. Nr.: 7654

Punkthalter mit Aluminium-Senkbuchse Ø 29 mm und Aluminium-Unterlegscheibe

Plattendicke  8-12 mm

Material/Oberfläche E = Aluminium



EO

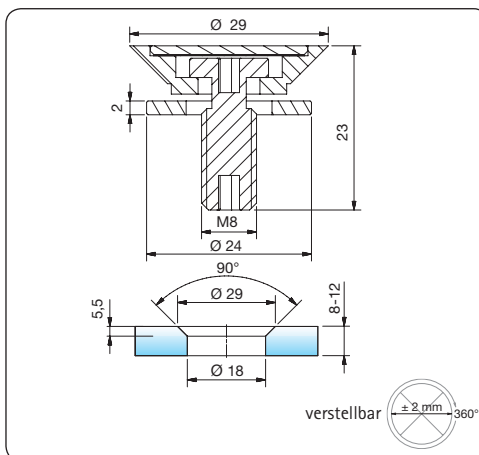

Art. Nr.: 7655

Punkthalter mit POM-Senkbuchse Ø 29 mm und Kunststoff-Unterlegscheibe

Plattendicke  8-12 mm

Material/Oberfläche VA = Edelstahl (A2)



VA

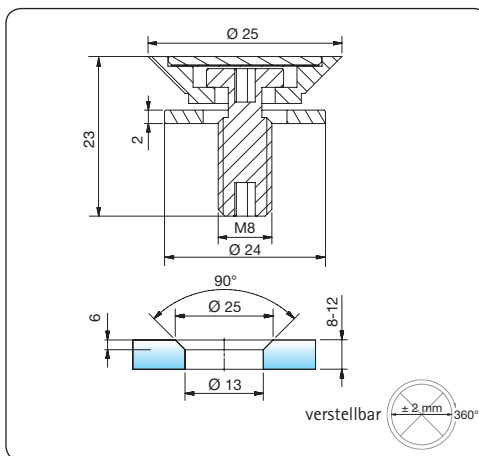

Art. Nr.: 7657

Punkthalter mit POM-Senkbuchse Ø 25 mm und Kunststoff-Unterlegscheibe

Plattendicke  8-12 mm

Material/Oberfläche VA = Edelstahl (A2)



VA

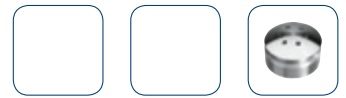

■ Punkthalter flächenbündig





■ Punkthalter flächenbündig

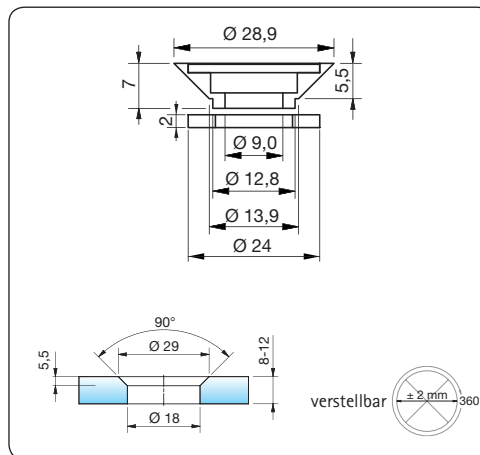

Art. Nr.: 7651

Punkthalter mit Aluminium-Senkbuchse Ø 29 mm
Kunststoff-Unterlegscheibe und
Aluminium-Abdeckplatte

Plattendicke  8-12 mm

Material/Oberfläche E = Aluminium

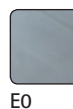

EO

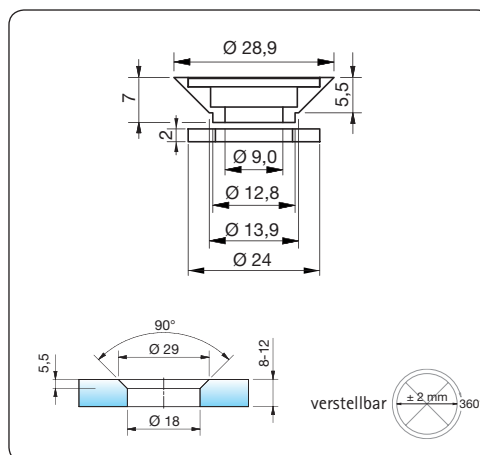

Art. Nr.: 7651

Punkthalter mit POM-Senkbuchse Ø 29 mm
Kunststoff-Unterlegscheibe und
Edelstahl-Abdeckplatte

Plattendicke  8-12 mm

Material/Oberfläche VA = Edelstahl (A2)



VA

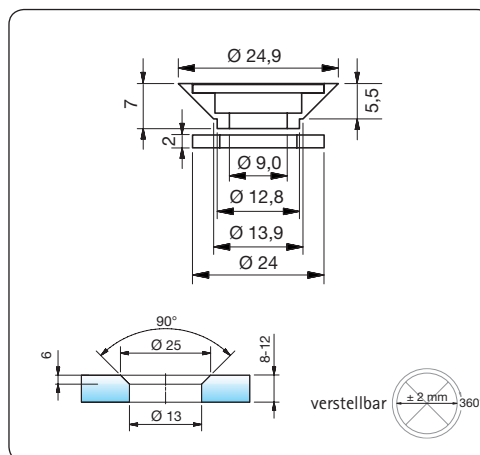

Art. Nr.: 7652

Punkthalter mit POM-Senkbuchse Ø 25 mm
Kunststoff-Unterlegscheibe und
Edelstahl-Abdeckplatte

Plattendicke  8-12 mm

Material/Oberfläche VA = Edelstahl (A2)



VA



■ Punkthalter flächenbündig

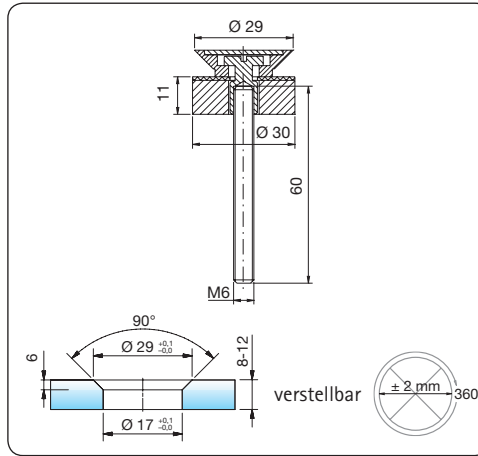

Art. Nr.: 7656

Punkthalter mit POM-Senkbuchse Ø 29 mm
Kunststoff-Unterlegscheibe

Belastungswerte: maxQ = 1,0 kN

Plattendicke  8-12 mm

Material/Oberfläche VA = Edelstahl (A2)



VA

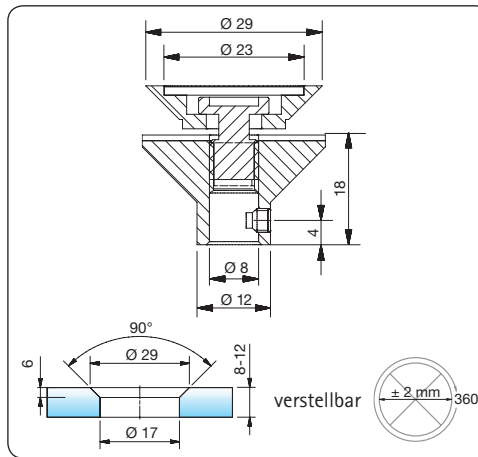

Art. Nr.: 7700

Punkthalter mit POM-Senkbuchse Ø 29 mm
Kunststoff-Unterlegscheibe,
mit Adapteranschluss Ø 8 mm

Plattendicke  8-12 mm

Material/Oberfläche VA = Edelstahl (A2)



VA

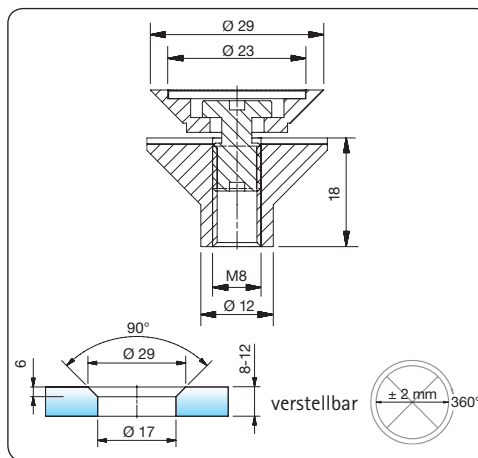

Art. Nr.: 7701

Punkthalter mit POM-Senkbuchse Ø 29 mm
Kunststoff-Unterlegscheibe,
mit M8-Anschluss

Plattendicke  8-12 mm

Material/Oberfläche VA = Edelstahl (A2)



VA



■ Punkthalter flächenbündig

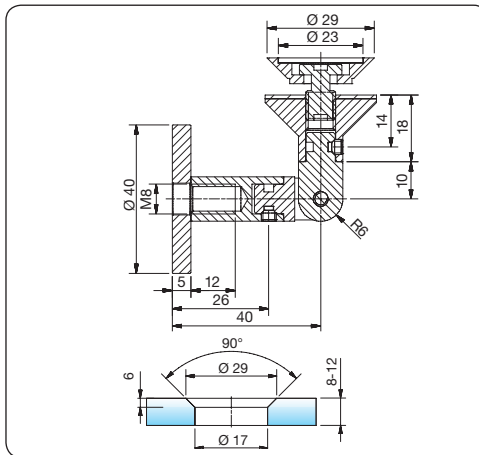

Art. Nr.: 7714

Wandbefestigung mit Punkthalter Ø 29 mm mit POM-Senkbuchse und Kunststoff-Unterlegscheibe, 180° verstellbar

Plattendicke  8-12 mm

Material/Oberfläche VA = Edelstahl (A2)



VA

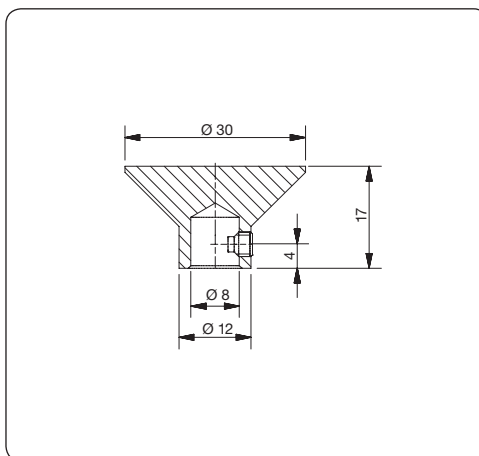

Art. Nr.: 7726

Punkthalter für UV-Verklebung Ø 30 mm mit Adapteranschluss ø 8 mm

Plattendicke  8-12 mm

Material/Oberfläche VA = Edelstahl (A2)



VA



■ Punkthalter flächenbündig

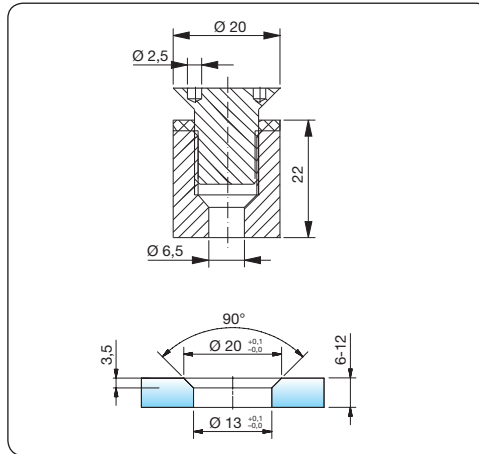
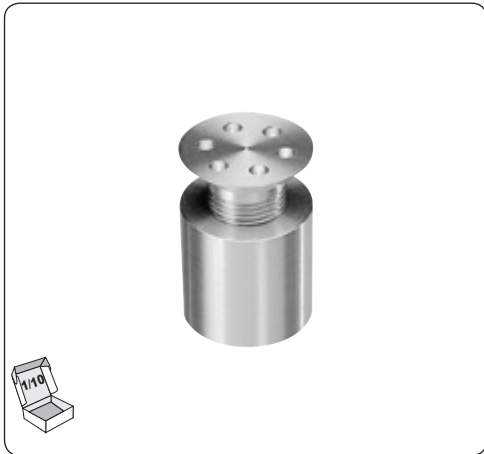

Art. Nr.: 7060

Punkthalter Ø 20 mm

Belastungswerte: maxQ = 2,5 kN

Plattendicke 8-12 mm

Material/Oberfläche E = Aluminium



E0

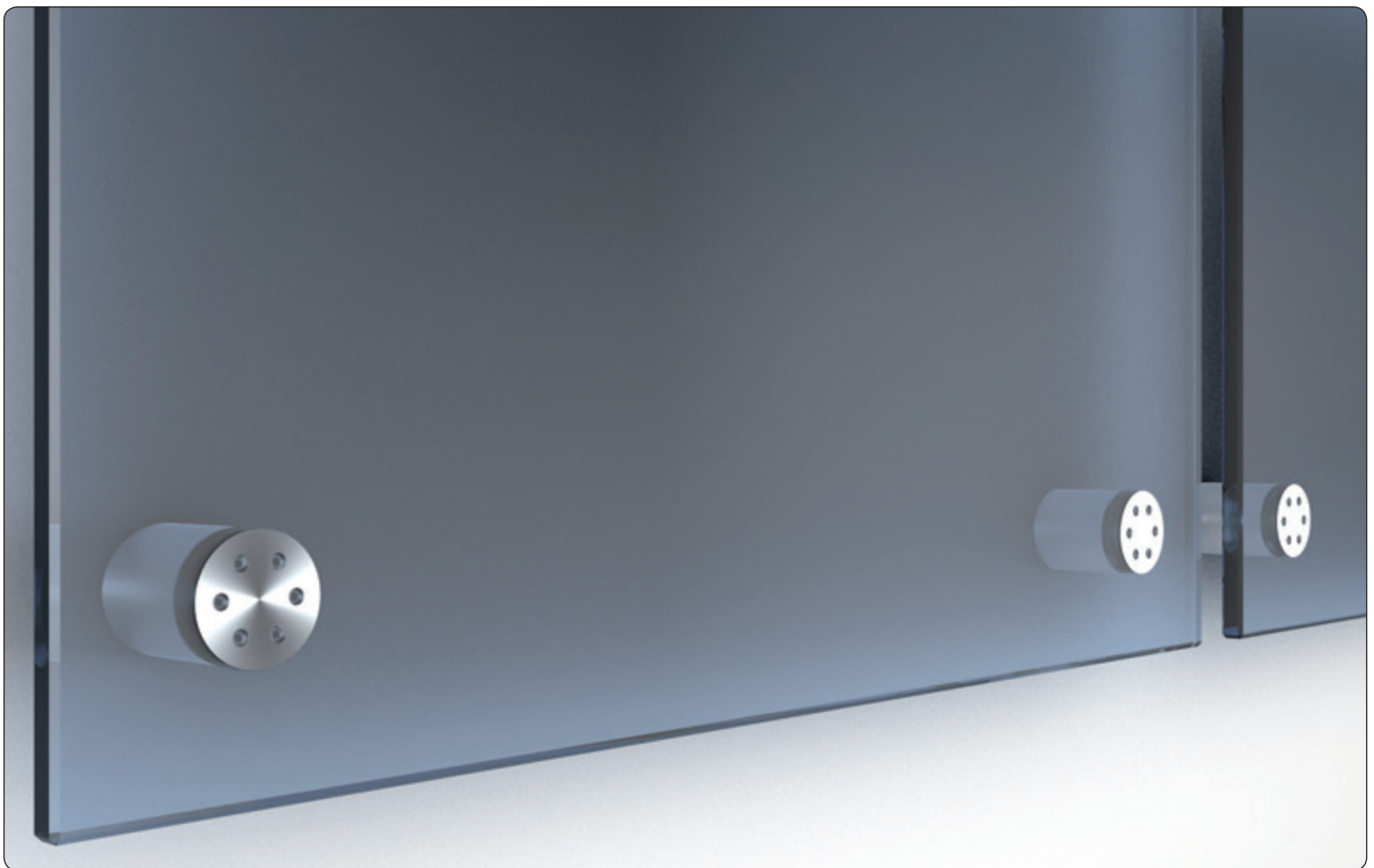
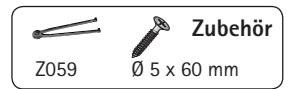



■ Punkthalter flächenbündig

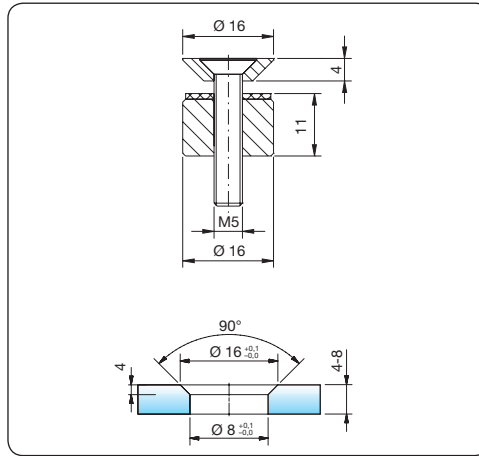
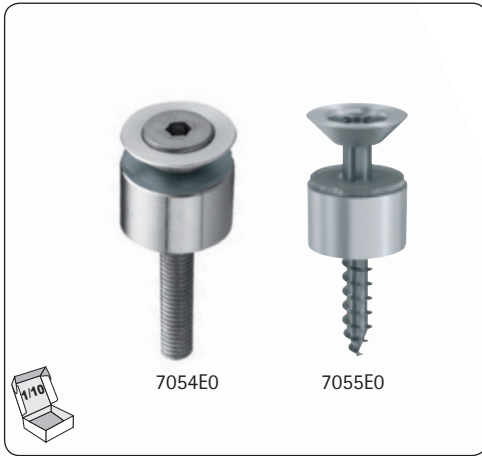

Art. Nr.: 7054, 7055

Punkthalter Ø 16 mm
mit Kunststoff-Unterlegscheibe

Belastungswerte: maxQ = 0,5 kN

Plattendicke 4-8 mm

Material/Oberfläche E = Aluminium

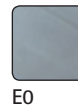

Inklusive
 bei 7054E0
 DIN 7991 M5x40 mm
 bei 7055E0 5x40 mm



Zubehör

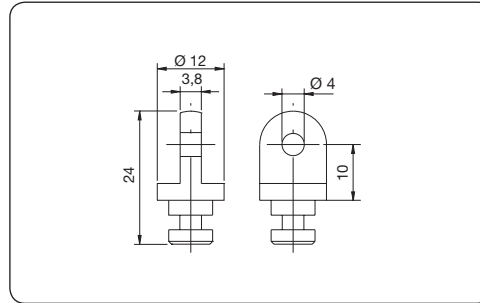

Art. Nr.: 7700-11

Steck-Öse

Material/Oberfläche VA = Edelstahl (A2)



VA

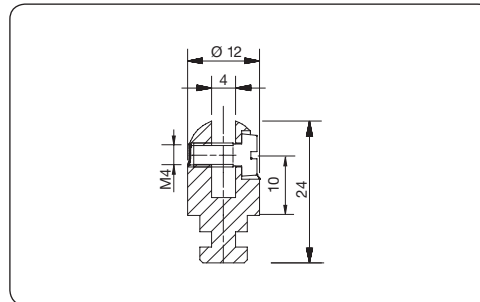

Art. Nr.: 7704

Steck-Gabel mit Adapter

Material/Oberfläche VA = Edelstahl (A2)



VA



Zubehör

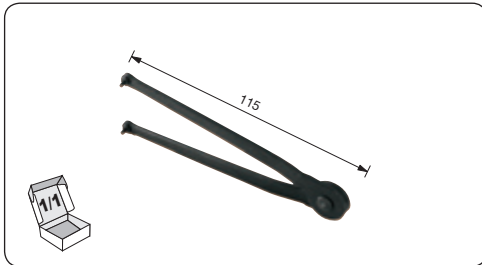

Art. Nr.: Z059

Verstellbarer Stirnlochschlüssel 2,5 mm

Lochzapfen Ø 2,5 mm, Länge 3 mm

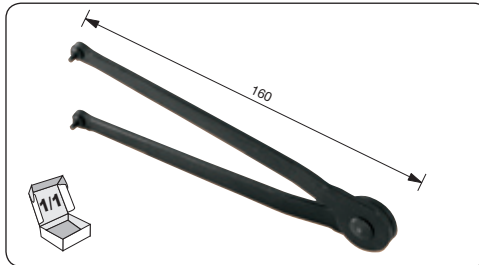

Art. Nr.: Z058

Verstellbarer Stirnlochschlüssel 3 mm

Lochzapfen Ø 3 mm, Länge 4 mm

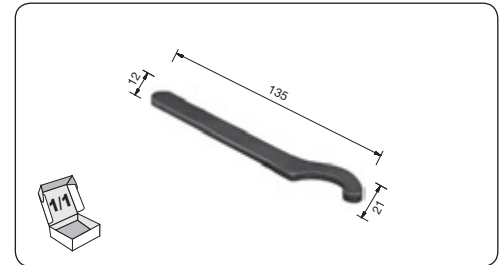

Art. Nr.: Z057

Hakenschlüssel

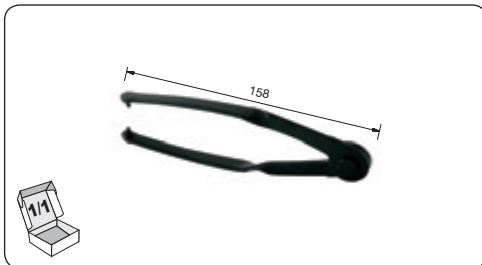

Art. Nr.: Z060

Verstellbarer Spezialschlüssel 3 mm

Lochzapfen Ø 3 mm, Länge 4 mm



Art. Nr.: S7997A2D5X60

Holzsenkkopfschraube 5 x 60 mm



Art. Nr.: S912A2D

Zylinderkopfschraube DIN 912

S912A2D8X80

8 x 80

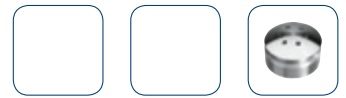

■ Befestigungswinkel





■ Befestigungswinkel

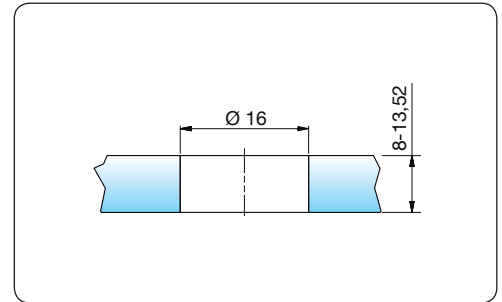
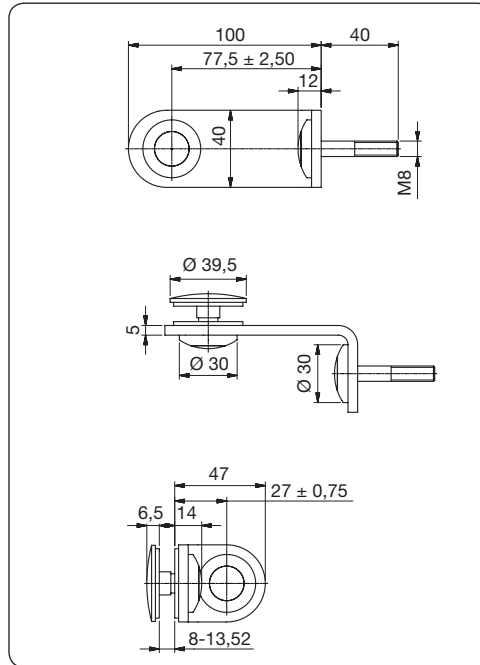

Art. Nr.: 7065

Punkthalter mit Befestigungswinkel

Plattendicke  8-13,52 mm

Material/Oberfläche VA = Edelstahl (A2)



VA



■ Punkthalter – unbegrenzte Möglichkeiten



Punkthalter finden nicht nur Anwendung im Innenausbau sondern auch bei sicherheitsrelevanten Anwendungen wie Brüstungen, Überkopfverglasungen, Vordächer und Fassaden. Hier werden natürlich besonders hohe Anforderungen an Tragfähigkeit und Dauerhaftigkeit gestellt. Oft sind die Nachweise, die zu führen sind, sehr aufwendig. Außerdem ist oft eine Zustimmung im Einzelfall von der zuständigen Bauaufsicht einzuholen oder aufwendige Bauteilversuche durchzuführen.

Pauli + Sohn bietet viele Systeme an:

- mit Allgemeiner bauaufsichtlicher Zulassung
- mit statischer Berechnung
- mit Versuchsberichten
- mit Europäischer technischer Zulassung

So reduziert sich der Aufwand auf ein Minimum. Welche Punkthalter für Ihr Bauvorhaben besonders gut geeignet ist, finden Sie in unseren Broschüren, unter www.pauli.de oder telefonisch. Wir beraten Sie gerne.





■ Punkthalter – unbegrenzte Möglichkeiten



Checkliste

1. Handelt es sich um eine Brüstung, Fassade oder Überkopfverglasung?
2. Haben die Scheiben eine absturzsichernde Funktion?
3. Wirken Lasten wie z. B. Wind oder Schnee auf die Scheibe?



Informationen

Ausführliche Informationen zu Produkten und sicherheitsrelevanten Vorgaben für die Verbauung von Brüstungen, Vordächern und Überkopfverglasungen erhalten Sie in den Brüstungswelten bzw. Glasdachwelten.



Informationen zu Produkten und sicherheitsrelevanten Vorgaben für die Verbauung von Punkthalterfassaden, wie auch verschiedene Schulungen zu diesen Themen finden Sie im Internet unter www.pauli.de
Desweiteren bieten wir verschiedene Schulungen zu diesen Themen an. Auch hier finden Sie alle Informationen im Internet auf www.pauli.de





- Glasplattenträger
Verbindersystem
Klemmen



■ Inhalt



| | |
|--|-----|
| ■ Glasplattenträger Zink | 175 |
| Glasplattenträger Edelstahl | 187 |
| Glasplattenträger Zink „Design-Kollektion“ | 195 |
| Verbindersystem | 200 |
| Klemmen | 205 |

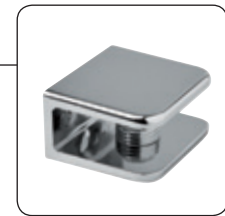

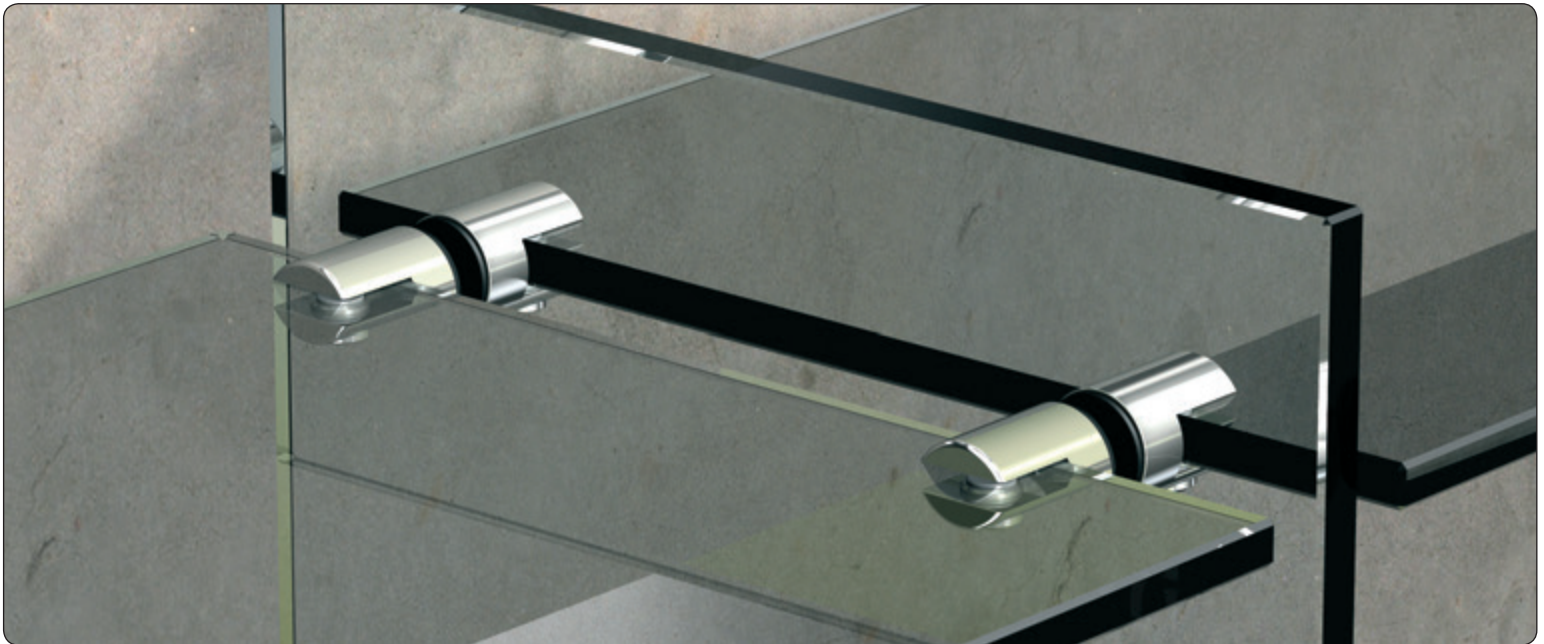

■ Kurzbezeichnungen für Material- und Ausführungsarten

ZN = Zink

| | | |
|--|------|------------------|
|  | ZN0 | = roh |
|  | ZN1 | = mattverchromt |
|  | ZN5 | = glanzverchromt |
|  | ZN7 | = glanzvergoldet |
|  | ZN22 | = Edelstahloptik |
|  | RAL | = RAL Farben |



ST = Stahl

| | | |
|--|-----|------------|
|  | ST8 | = verzinkt |
|--|-----|------------|



MS = Messing

| | | |
|---|------|-----------------------|
|  | MS5 | = poliert, vernickelt |
|  | MS7 | = glanzverchromt |
|  | MS10 | = mattverchromt |
|  | MS15 | = vergoldet |

VA = Edelstahl

| | | |
|---|-----|------------------|
|  | VA1 | = poliert |
|  | VA2 | = matt gebürstet |
|  | VA0 | = roh |

E = Aluminium

| | | |
|---|--------|-------------------------------------|
|  | E6/EV1 | = Alu-Optik (silberfarbig eloxiert) |
|  | E3/EV1 | = Alu-Optik |
|  | E6/EV5 | = glanzeloxiert |

KU = Kunststoff

| | | |
|---|-----|-----------------|
|  | KU0 | = transparent |
|  | KU1 | = weiß |
|  | KU3 | = schwarz |
|  | KU6 | = mattverchromt |

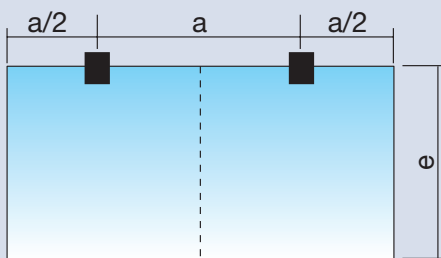

■ Tragfähigkeit Glasplattenträger

Die Maximallast kann als empfohlener Wert verstanden werden. Die Bruchlast liegt erheblich über dem empfohlenen Wert. Eine Erweiterung des Glasfeldes ist natürlich möglich, bitte beachten Sie dabei die maximale Abmessung max. a. Die angegebene Tragfähigkeit gilt bei gleichmäßiger Lastverteilung.



■ Tragfähigkeit Glasplattenträger

Ergebnisse beziehen sich auf die Verwendung von 4 Haltern.
Die Glasplattenträger sind gegenüberliegend zu verbauen.

Die angegebene Tragfähigkeit gilt bei gleichmäßiger Lastverteilung.



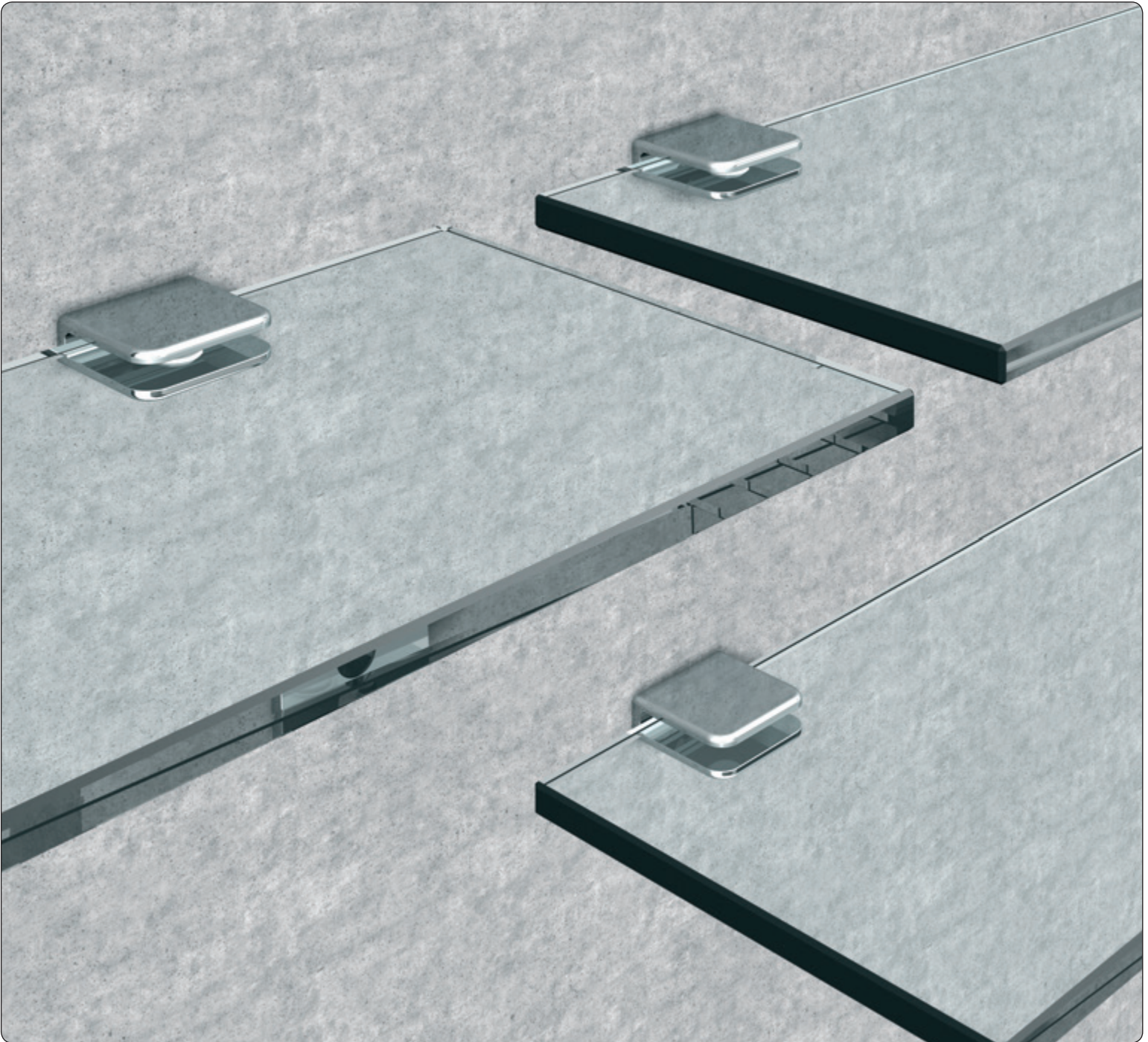

- Glasplattenträger aus hochwertigem Zink (ZN - ZAMAK®), Messing (MS) und Aluminium (E)





■ Glasplattenträger aus Zink (ZN - ZAMAK®)

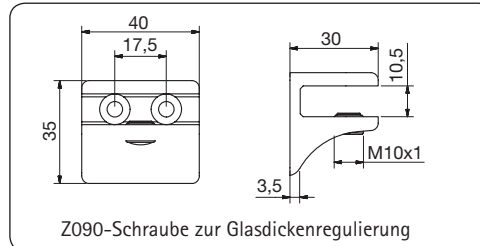

Tragfähigkeit:

| max. a | e1 | e2 | e3 | |
|--------|---------|---------|---------|------|
| | 100 mm | 200 mm | 300 mm | |
| 500 mm | 37,5 kg | 18,7 kg | 12,5 kg | 6 mm |

a = Abstand Glasplattenhalter, e = Ausladung

Art. Nr.: 2885

Glasplattenträger

2 Befestigungsbohrungen Ø 5,3 mm
für Senkkopfschrauben

Plattendicke: 6–10 mm

Material/Oberfläche ZN = Zink



Inklusive
Z090

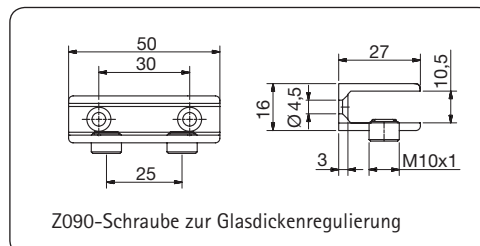

Tragfähigkeit:

| max. a | e1 | e2 | e3 | |
|--------|--------|---------|--------|------|
| | 100 mm | 200 mm | 300 mm | |
| 300 mm | 7,5 kg | 3,75 kg | 2,5 kg | 6 mm |

a = Abstand Glasplattenhalter, e = Ausladung

Art. Nr.: 2882

Glasplattenträger

2 Befestigungsbohrungen Ø 4,5 mm
für Senkkopfschrauben

Plattendicke: 6–10 mm

Material/Oberfläche ZN = Zink



Inklusive
Z090

ZN22





■ Glasplattenträger aus Zink (ZN - ZAMAK®)

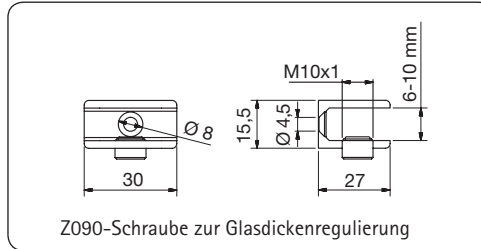

Tragfähigkeit:

| max. a | e1 | e2 | e3 | |
|--------|--------|---------|--------|------|
| | 100 mm | 200 mm | 300 mm | |
| 300 mm | 7,5 kg | 3,75 kg | 2,5 kg | 6 mm |

a = Abstand Glasplattenhalter, e = Ausladung

Art. Nr.: 2880

Glasplattenträger

1 Befestigungsbohrung Ø 4,5 mm
für Senkkopfschraube

Plattendicke: 6-10 mm

Material/Oberfläche ZN = Zink

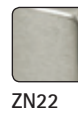

Inklusive
Z090

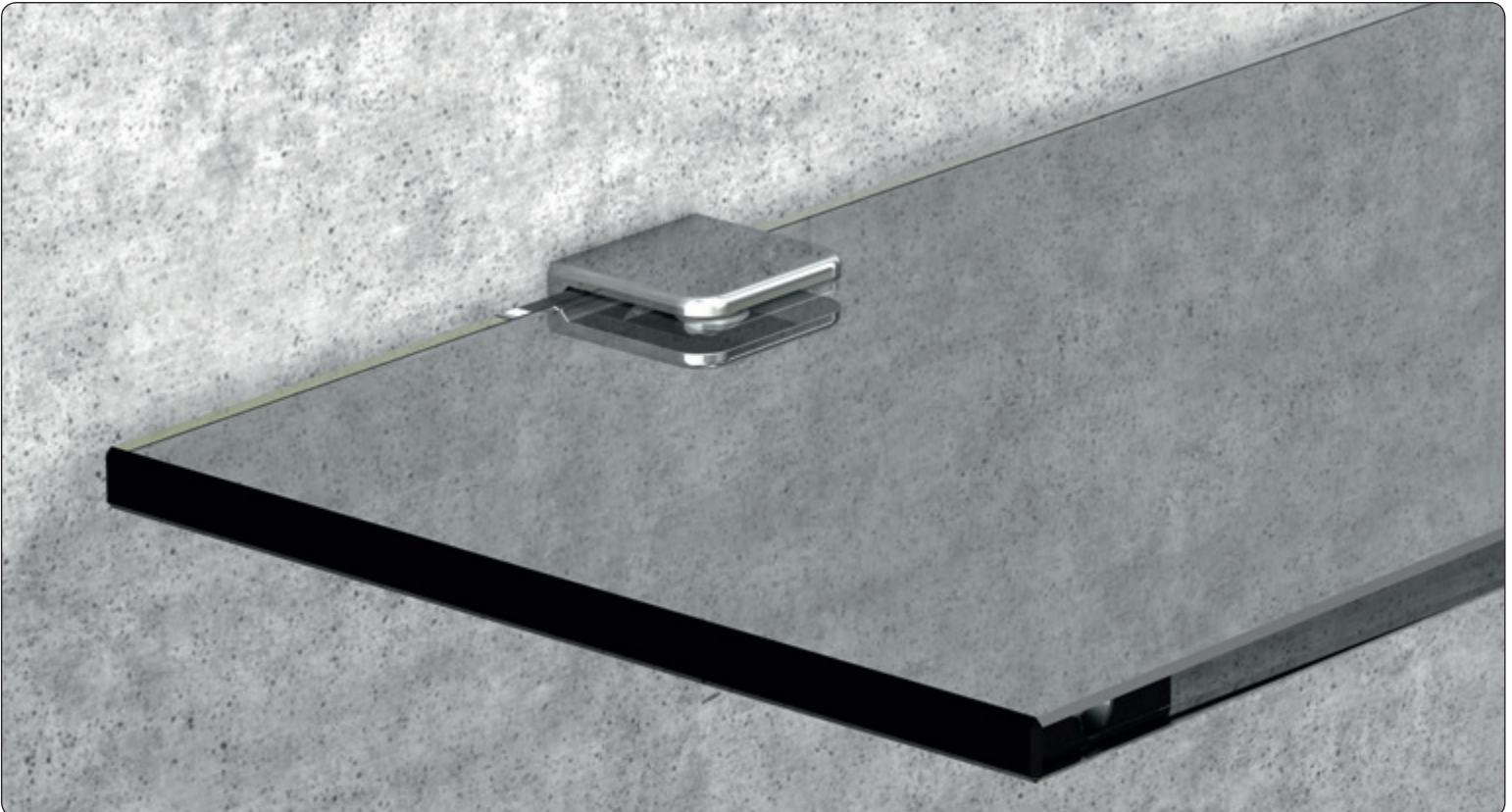



■ Glasplattenträger aus Zink (ZN - ZAMAK®)

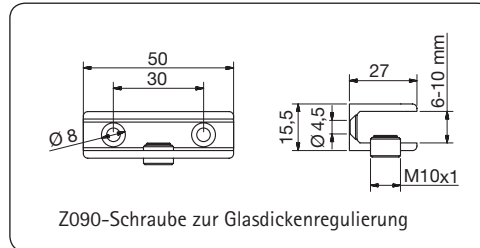

Tragfähigkeit:

| max. a | e1 | e2 | e3 | |
|--------|--------|---------|--------|------|
| | 100 mm | 200 mm | 300 mm | |
| 300 mm | 7,5 kg | 3,75 kg | 2,5 kg | 6 mm |

a = Abstand Glasplattenhalter, e = Ausladung

Art. Nr.: 2884

Glasplattenträger

2 Befestigungsbohrungen Ø 4,5 mm für Senkkopfschrauben

Plattendicke: 6–10 mm

Material/Oberfläche ZN = Zink

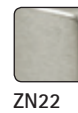

Inklusive Z090

Art. Nr.: 2881

Glasplattenträger

2 Befestigungsbohrungen Ø 4,5 mm für Senkkopfschrauben

Plattendicke: 6–10 mm

Material/Oberfläche ZN = Zink



Inklusive Z090

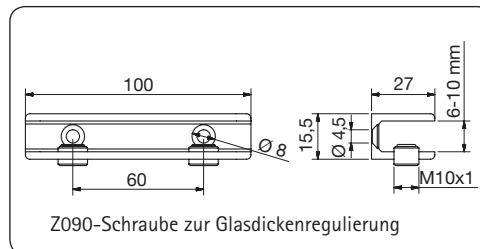

Tragfähigkeit:

| max. a | e1 | e2 | e3 | |
|--------|---------|---------|---------|------|
| | 100 mm | 200 mm | 300 mm | |
| 500 mm | 30,0 kg | 15,0 kg | 10,0 kg | 6 mm |

a = Abstand Glasplattenhalter, e = Ausladung

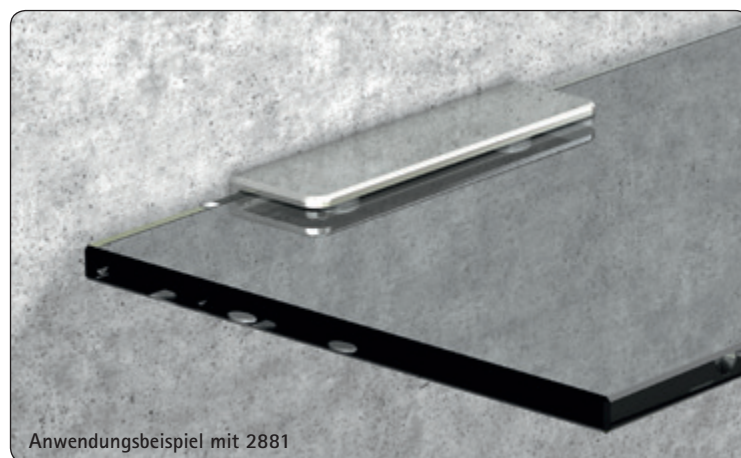



■ Glasplattenträger aus Zink (ZN - ZAMAK®)

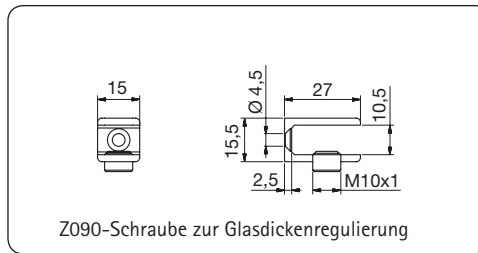

Tragfähigkeit:

| max. a | e1 | e2 | e3 | |
|--------|--------|---------|--------|------|
| | 100 mm | 200 mm | 300 mm | |
| 300 mm | 4,5 kg | 2,25 kg | 1,5 kg | 6 mm |

a = Abstand Glasplattenhalter, e = Ausladung

Art. Nr.: 2886

Glasplattenträger

1 Befestigungsbohrung Ø 4,5 mm für Senkkopfschraube

Plattendicke: 6–10 mm

Material/Oberfläche ZN = Zink



Inklusive Z090

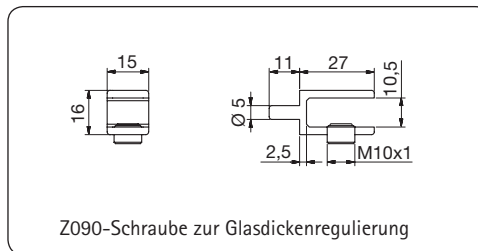

Tragfähigkeit:

max. 8 kg

Ergebnisse beziehen sich auf die Verwendung von 4 Haltern. Die Glasplattenträger sind gegenüberliegend zu verbauen.

Art. Nr.: 2887

Glasplattenträger

mit Zapfen Ø 5 x 11 mm Länge, für Lochwände

Plattendicke: 6–10 mm

Material/Oberfläche ZN = Zink



Inklusive Z090

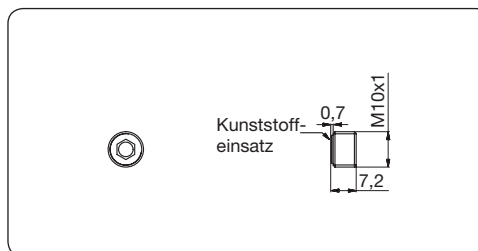
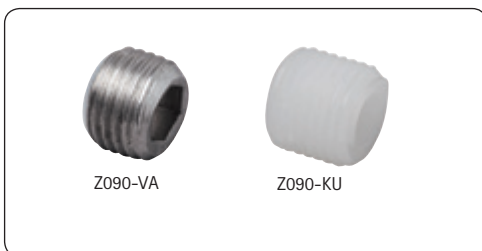

Art. Nr.: Z090-VA

Gewindestift M10x1x7 mit Kunststoffeinsatz

Material/Oberfläche VA = Edelstahl

Art. Nr.: Z090-KU

Gewindestift M10x1x8

Material/Oberfläche KU = Kunststoff

Glasplattenträger



■ Glasplattenträger aus Zink (ZN - ZAMAK®)

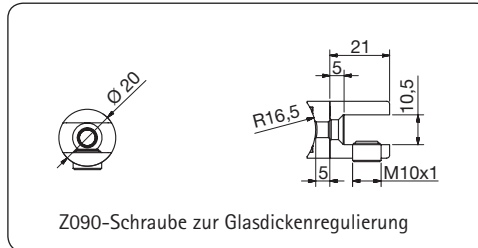

Tragfähigkeit:

max. 8 kg

Ergebnisse beziehen sich auf die Verwendung von 4 Haltern.
Die Glasplattenträger sind gegenüberliegend zu verbauen.

Art. Nr.: 2873

Glasplattenträger mit Rundrohradapter
für Ø 27-33 mm

1 Befestigungsbohrung Ø 7 mm im Glashalter und
Ø 5,5 mm im Adapter für M5-Senkkopfschraube

Plattendicke: 6-10 mm

Material/Oberfläche ZN = Zink



Inklusive
Z090

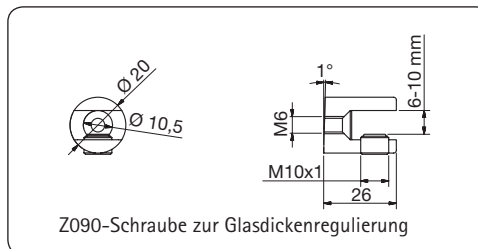

Tragfähigkeit:

| max. a | e1 | e2 | e3 | |
|--------|--------|--------|--------|--|
| | 100 mm | 200 mm | 300 mm | |

| | | | | |
|--------|--------|---------|--------|------|
| 300 mm | 7,5 kg | 3,75 kg | 2,5 kg | 6 mm |
|--------|--------|---------|--------|------|

a = Abstand Glasplattenhalter, e = Ausladung

Art. Nr.: 2877

Glasplattenträger

1 Befestigungsbohrung M6 und zusätzlicher
Senkung für M5-Senkkopfschraube

Plattendicke: 6-10 mm

Material/Oberfläche ZN = Zink



Inklusive
Z090

Zubehör
2878, 2879

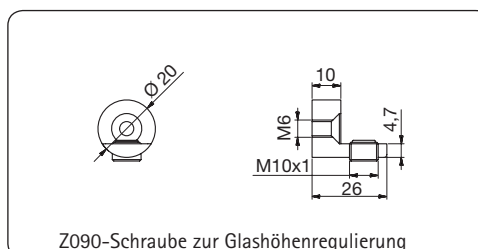

Tragfähigkeit:

max. 8 kg

Ergebnisse beziehen sich auf die Verwendung von 4 Haltern.
Die Glasplattenträger sind gegenüberliegend zu verbauen.

Art. Nr.: 2883

Glasplattenträger

1 Befestigungsbohrung M6 und zusätzlicher
Senkung für M5-Senkkopfschraube

Material/Oberfläche ZN = Zink



Inklusive
Z090

Zubehör
2878, 2879



Zubehör

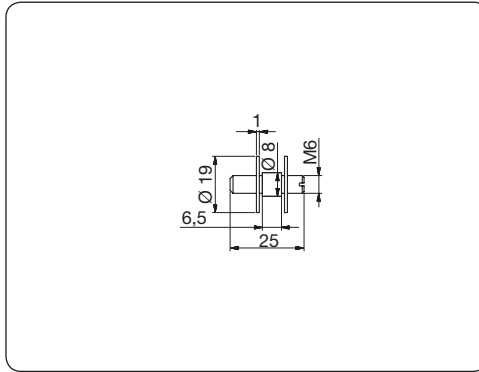
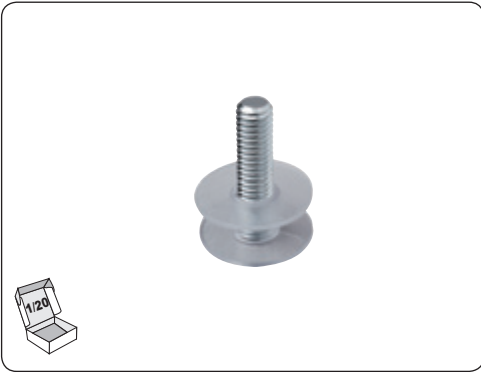

Art. Nr.: 2878

Gewindestift M6x25
2 KU-Unterlegscheiben,
1 KU-Schlauchstück Ø 8 x Ø 6 x 6,5 mm

Material/Oberfläche ST = Stahl



ST8

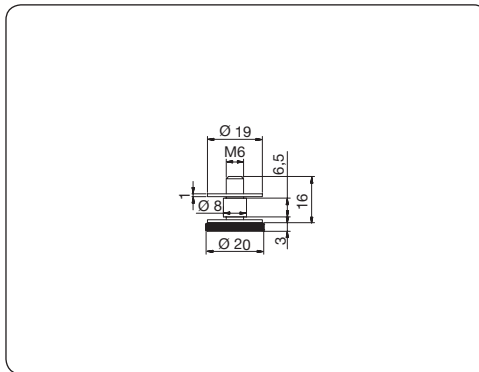
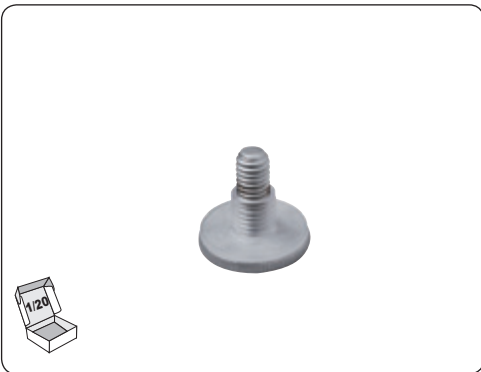

Art. Nr.: 2879

Rändelschraube M6x16
2 KU-Unterlegscheiben,
1 KU-Schlauchstück Ø 8 x Ø 6 x 6,5 mm

Material/Oberfläche VA = Edelstahl



VA0



VA1



VA2



Anwendungsbeispiel zu 2877, 2883 in
Verwendung mit 2878 und 2879

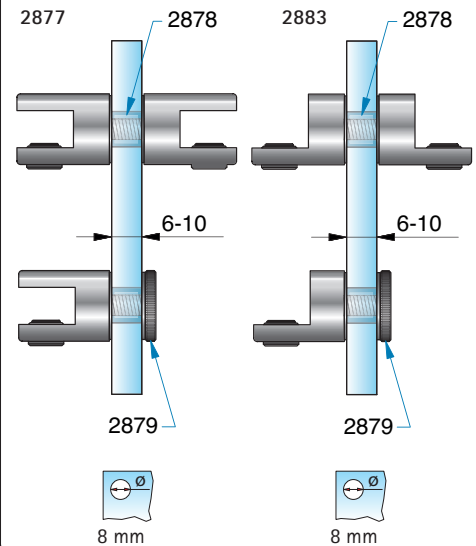



■ Glasplattenträger aus Messing (MS)

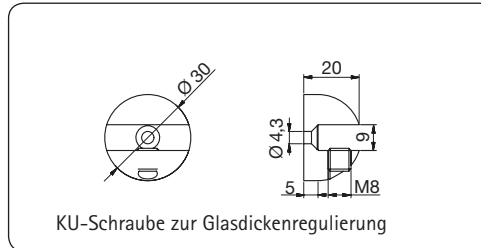

Tragfähigkeit:

| max. a | e1 | e2 | e3 | |
|--------|--------|---------|--------|------|
| | 100 mm | 200 mm | 300 mm | |
| 300 mm | 7,5 kg | 3,75 kg | 2,5 kg | 6 mm |

a = Abstand Glasplattenhalter, e = Ausladung

Art. Nr.: 2876

Glasplattenträger

1 Befestigungsbohrung Ø 4,3 mm
für Senkkopfschrauben

Plattendicke: 6–8 mm

Material/Oberfläche MS = Messing



MS7



MS15

Inklusive
Z090

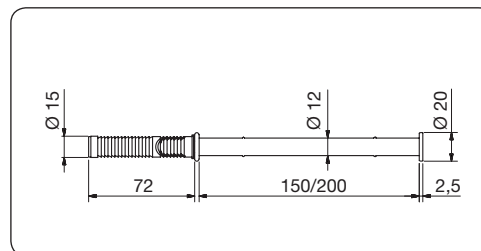

Tragfähigkeit:

| max. a | e1 | e2 | |
|--------|---------|--------|------|
| | 150 mm | 200 mm | |
| 300 mm | 11,0 kg | 8,0 kg | 6 mm |

a = Abstand Glasplattenhalter, e = Ausladung

Art. Nr.: 10050

Glasplattenträger inkl. Dübel

Ausladung 150, 200 mm

Material/Oberfläche MS = Messing



MS10

Zubehör
10051 für überstehende
Glasscheiben

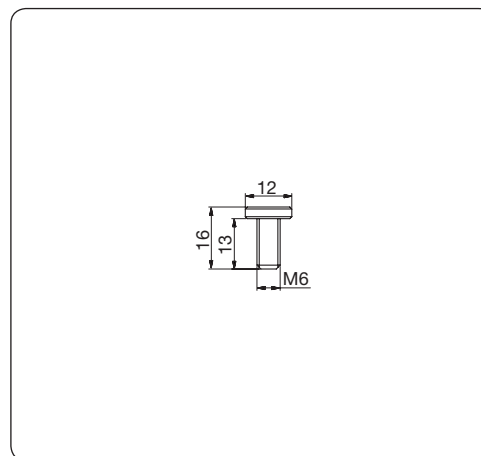

Art. Nr.: 10051

Schraube M6 für 10050

Material/Oberfläche MS = Messing



MS10



■ Glasplattenträger aus Messing (MS)

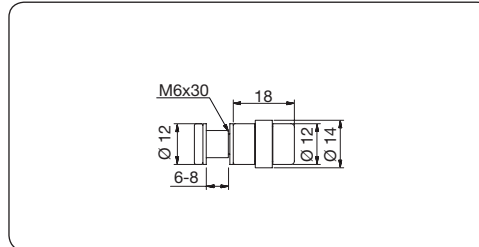

Tragfähigkeit:

max. 10 kg

Ergebnisse beziehen sich auf die Verwendung von 4 Haltern.
Die Glasplattenträger sind gegenüberliegend zu verbauen.

Art. Nr.: 2888

Glasplattenträger einseitig mit Gummiauflage

Im Lieferumfang enthalten:
1 Gewindeschraube, 2 KU-Unterlegscheiben,
1 KU-Schlauchstück

Plattendicke:  6-8 mm

Material/Oberfläche MS = Messing



MS5

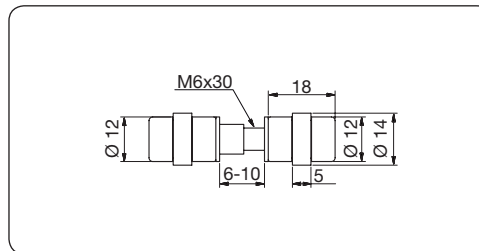

Tragfähigkeit:

max. 10 kg

Ergebnisse beziehen sich auf die Verwendung von 4 Haltern.
Die Glasplattenträger sind gegenüberliegend zu verbauen.

Art. Nr.: 2889

Glasplattenträger doppelseitig mit Gummiauflage

Im Lieferumfang enthalten:
1 Gewindeschraube, 2 KU-Unterlegscheiben,
1 KU-Schlauchstück

Plattendicke:  6-10 mm

Material/Oberfläche MS = Messing



MS5

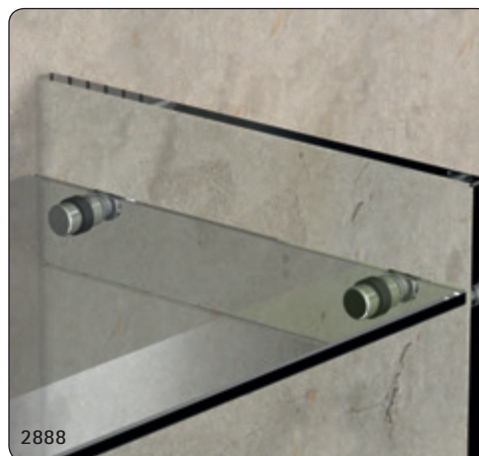
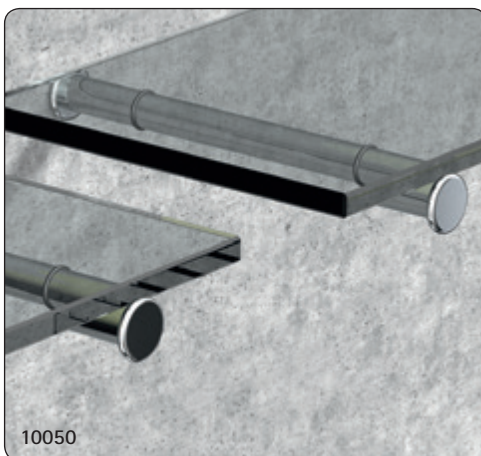



Lochschienträger aus Aluminium (E)

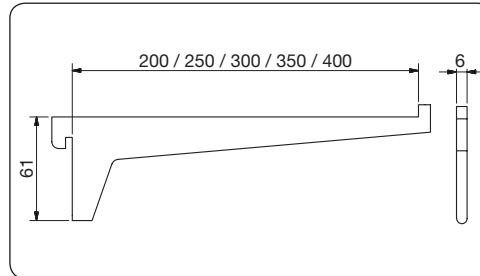

Tragfähigkeit:

| max. a | e2 | e3 | e4 | |
|--------|--------|--------|--------|--|
| | 200 mm | 300 mm | 400 mm | |

≤ 1000 mm 130,0 kg* 110,0 kg* 80,0 kg* 6 mm

a = Abstand Glasplattenhalter, e = Ausladung * Tragfähigkeit pro Paar

Art. Nr.: 4956

Lochschienträger

Auflagebreite 200, 250, 300, 350, 400 mm

Material/Oberfläche E = Aluminium



E3/EV1

Zubehör

4955, 4957, 4958, 4959

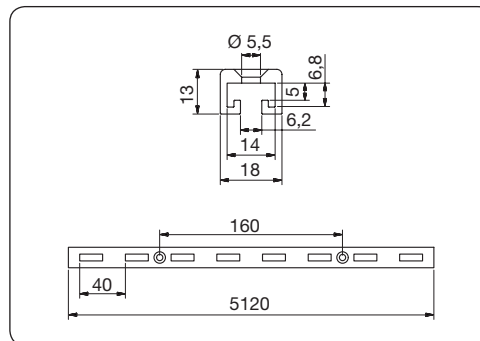

Art. Nr.: 4955

Lochschiene, Mehrfachböden inkl. Dübel

Material/Oberfläche E = Aluminium



E3/EV1

Zubehör

4956, 4957, 4958, 4959

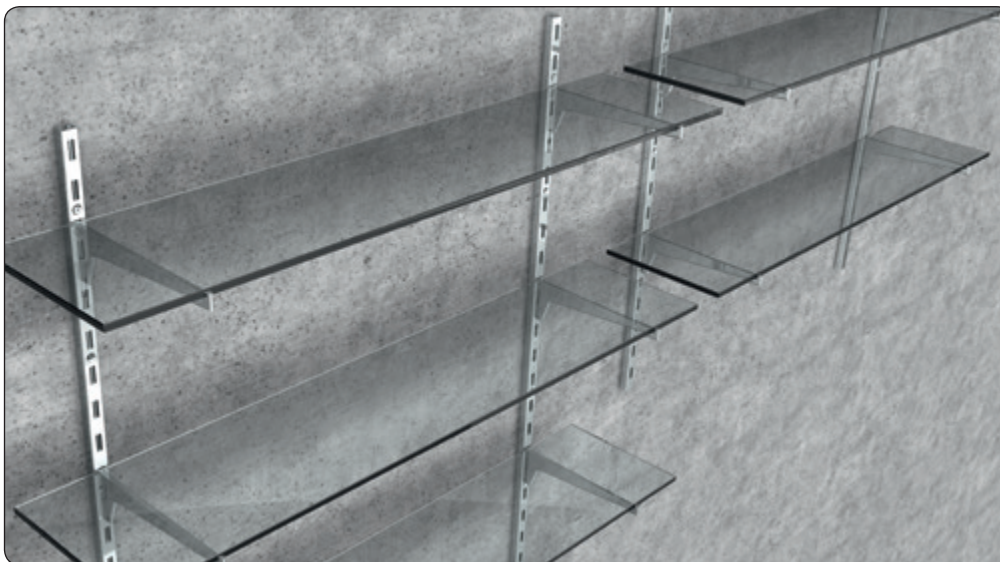



Zubehör

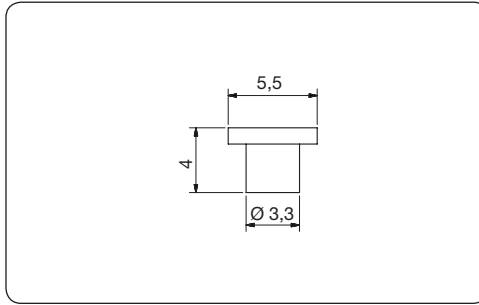

Art. Nr.: 4957

Stopfen zu Art. Nr. 4958

Material/Oberfläche

KU = Kunststoff



KU1

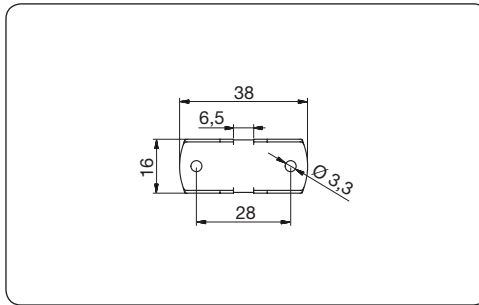

Art. Nr.: 4958

Querlappen zur Ablage

Material/Oberfläche

VA = Edelstahl



VA0

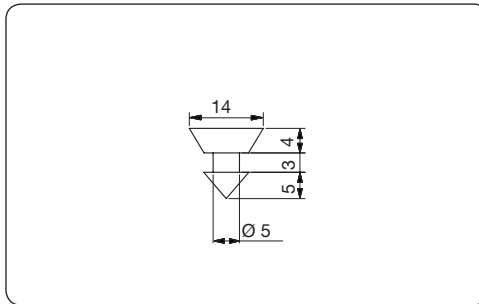

Art. Nr.: 3057

Saugfuss für Glasscheiben

Material/Oberfläche

KU = Kunststoff



KU0

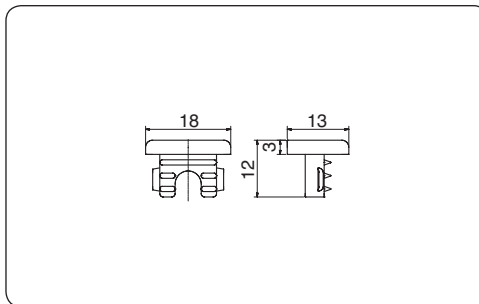

Art. Nr.: 4959

Abschlussstopfen

Material/Oberfläche

KU = Kunststoff



KU3

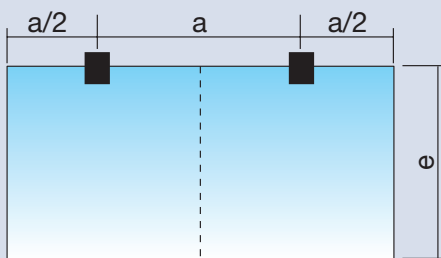

■ Tragfähigkeit Glasplattenträger

Die Maximallast kann als empfohlener Wert verstanden werden. Die Bruchlast liegt erheblich über dem empfohlenen Wert. Eine Erweiterung des Glasfeldes ist natürlich möglich, bitte beachten Sie dabei die maximale Abmessung max. a. Die angegebene Tragfähigkeit gilt bei gleichmäßiger Lastverteilung.



■ Tragfähigkeit Glasplattenträger

Ergebnisse beziehen sich auf die Verwendung von 4 Haltern.
Die Glasplattenträger sind gegenüberliegend zu verbauen.

Die angegebene Tragfähigkeit gilt bei gleichmäßiger Lastverteilung.

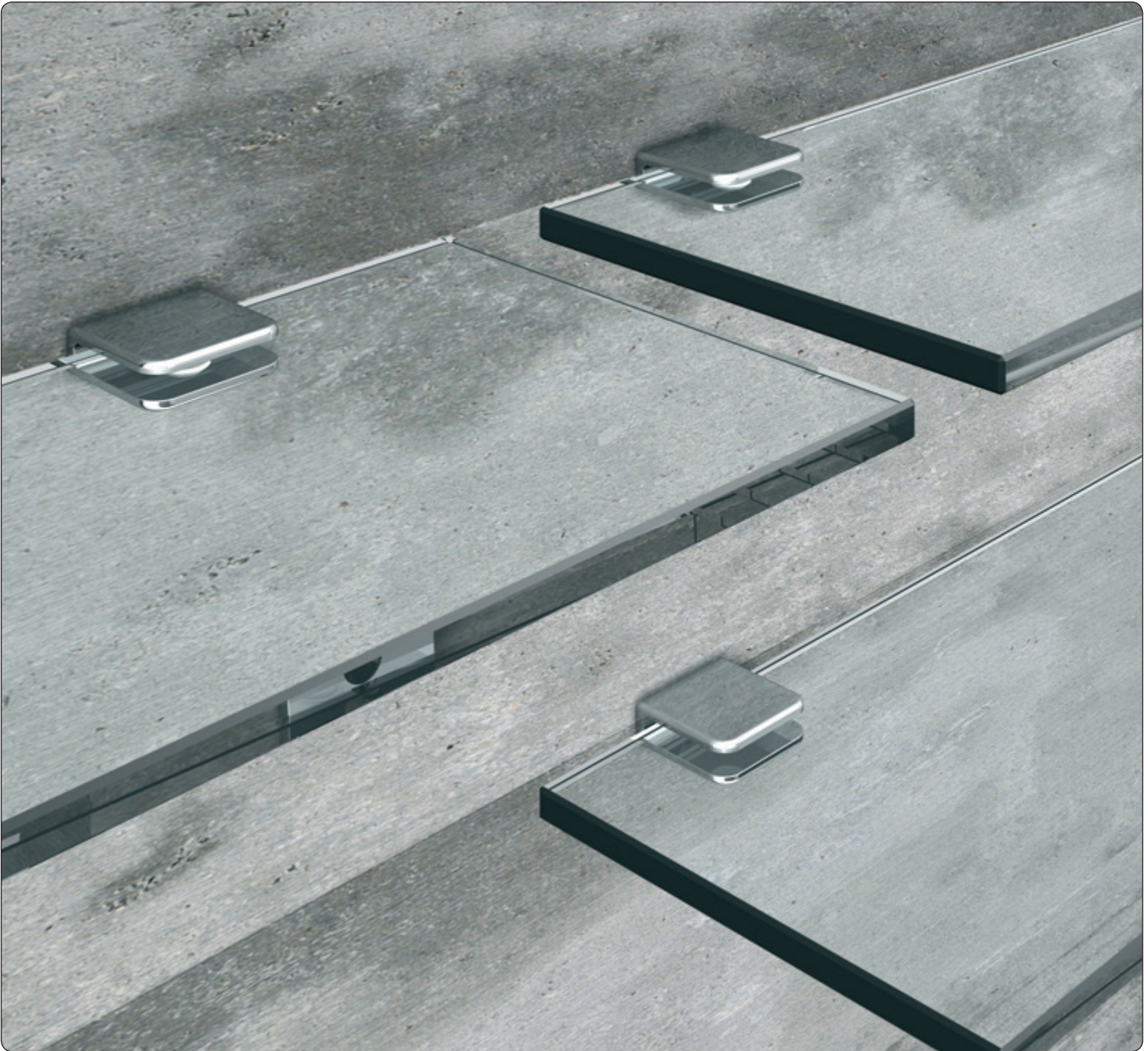

- Glasplattenträger aus Edelstahl (VA)





■ Glasplattenträger aus Edelstahl (VA)

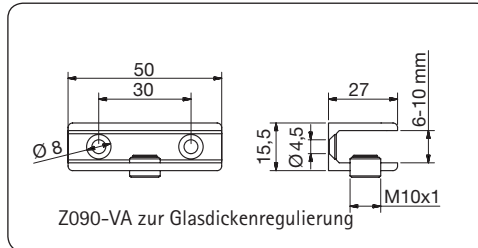

Tragfähigkeit:

| max. a | e1 | e2 | e3 | |
|--------|--------|---------|--------|------|
| | 100 mm | 200 mm | 300 mm | |
| 300 mm | 7,5 kg | 3,75 kg | 2,5 kg | 6 mm |

a = Abstand Glasplattenhalter, e = Ausladung

Art. Nr.: 2884

Glasplattenträger

2 Befestigungsbohrungen für Senkkopfschrauben \varnothing 4,5 mm

Plattendicke: 6–10 mm

Material/Oberfläche VA = Edelstahl



Inklusive Z090-VA

VA1

VA2

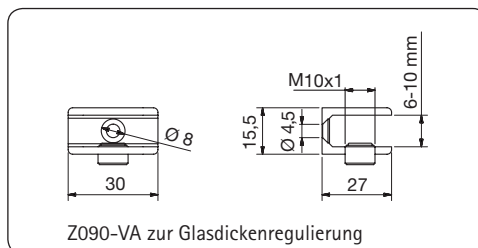

Tragfähigkeit:

| max. a | e1 | e2 | e3 | |
|--------|--------|---------|--------|------|
| | 100 mm | 200 mm | 300 mm | |
| 300 mm | 7,5 kg | 3,75 kg | 2,5 kg | 6 mm |

a = Abstand Glasplattenhalter, e = Ausladung

Art. Nr.: 2880

Glasplattenträger

1 Befestigungsbohrung für Senkkopfschraube \varnothing 4,5 mm

Plattendicke: 6–10 mm

Material/Oberfläche VA = Edelstahl



Inklusive Z090-VA

VA1

VA2

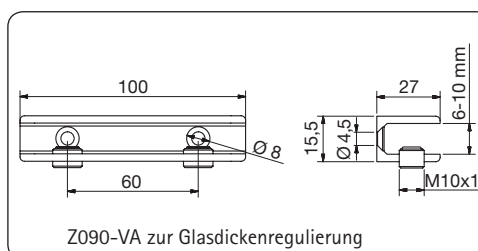

Tragfähigkeit:

| max. a | e1 | e2 | e3 | |
|--------|---------|---------|---------|------|
| | 100 mm | 200 mm | 300 mm | |
| 500 mm | 30,0 kg | 15,0 kg | 10,0 kg | 6 mm |

a = Abstand Glasplattenhalter, e = Ausladung

Art. Nr.: 2881

Glasplattenträger

2 Befestigungsbohrungen für Senkkopfschrauben \varnothing 4,5 mm

Plattendicke: 6–10 mm

Material/Oberfläche VA = Edelstahl



Inklusive Z090-VA

VA1

VA2



■ Glasplattenträger aus Edelstahl (VA)





■ Glasplattenträger aus Edelstahl (VA)

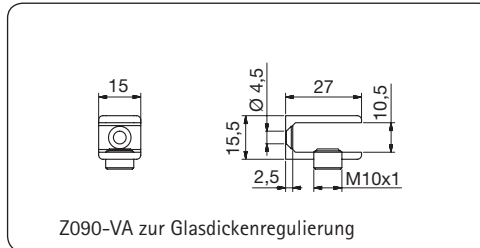

Tragfähigkeit:

| max. a | e1 | e2 | e3 | |
|--------|--------|---------|--------|------|
| | 100 mm | 200 mm | 300 mm | |
| 300 mm | 4,5 kg | 2,25 kg | 1,5 kg | 6 mm |

a = Abstand Glasplattenhalter, e = Ausladung

Art. Nr.: 2886

Glasplattenträger

1 Befestigungsbohrung Ø 4,5 mm für Senkkopfschraube

Plattendicke: 6–10 mm

Material/Oberfläche VA = Edelstahl

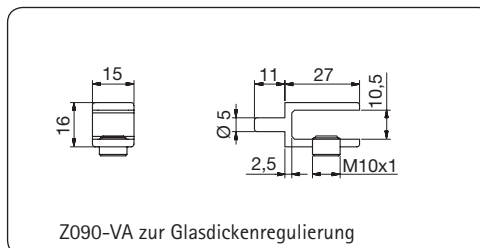
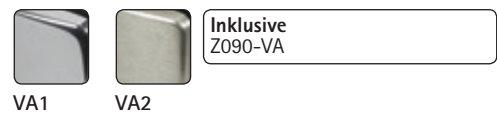

Tragfähigkeit:

| |
|------------|
| max. 10 kg |
|------------|

Ergebnisse beziehen sich auf die Verwendung von 4 Haltern. Die Glasplattenträger sind gegenüberliegend zu verbauen.

Art. Nr.: 2887

Glasplattenträger

mit 1 Zapfen Ø 5 x 11 mm Länge für Lochwände

Plattendicke: 6–10 mm

Material/Oberfläche VA = Edelstahl

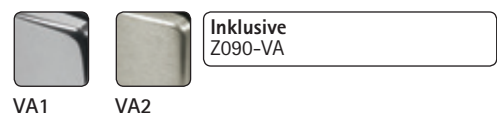

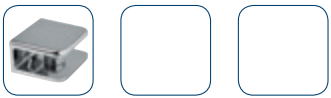

■ Glasplattenträger aus Edelstahl (VA)

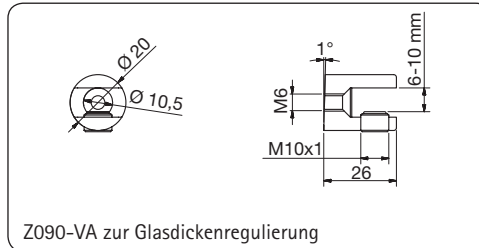

Z090-VA zur Glasdickenregulierung

Tragfähigkeit:

| max. a | e1 | e2 | e3 | |
|--------|--------|---------|--------|------|
| | 100 mm | 200 mm | 300 mm | |
| 300 mm | 7,5 kg | 3,75 kg | 2,5 kg | 6 mm |

a = Abstand Glasplattenhalter, e = Ausladung

Art. Nr.: 2877

Glasplattenträger

1 Befestigungsbohrung M6 und zusätzlicher Senkung für M5-Senkkopfschraube

Plattendicke: 6-10 mm

Material/Oberfläche VA = Edelstahl



VA1



VA2

Inklusive Z090

Zubehör 2878, 2879

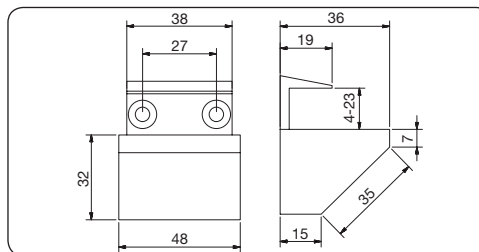

Tragfähigkeit:

| max. a | e1 | e2 | e3 | |
|--------|---------|---------|---------|------|
| | 100 mm | 200 mm | 300 mm | |
| 500 mm | 30,0 kg | 15,0 kg | 10,0 kg | 6 mm |

a = Abstand Glasplattenhalter, e = Ausladung

Art. Nr.: 4938

Regalbodenträger, stufenlos verstellbar

2 Befestigungsbohrungen Ø 5,3 mm für Senkkopfschrauben

Plattendicke: 4-23 mm

Material/Oberfläche VA = Edelstahl



VA1



VA2

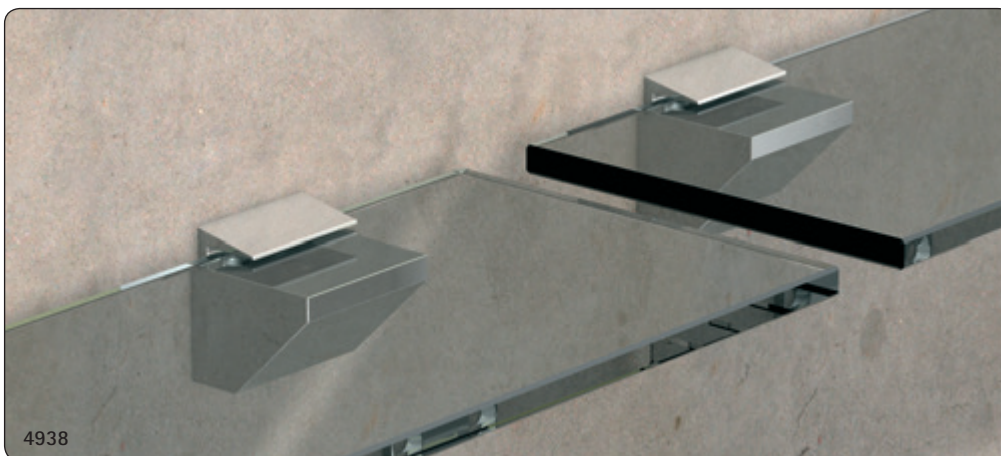

4938



■ Glasplattenträger aus Edelstahl (VA)

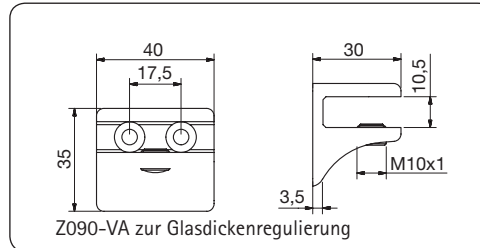

Tragfähigkeit:

| max. a | e1 | e2 | e3 | |
|--------|---------|---------|---------|------|
| | 100 mm | 200 mm | 300 mm | |
| 500 mm | 37,5 kg | 18,7 kg | 12,5 kg | 6 mm |

a = Abstand Glasplattenhalter, e = Ausladung

Art. Nr.: 2885

Glasplattenträger

2 Befestigungsbohrungen Ø 5,3 mm
für Senkkopfschrauben

Plattendicke: 6–10 mm

Material/Oberfläche VA = Edelstahl



VA1



VA2

Inklusive
Z090-VA

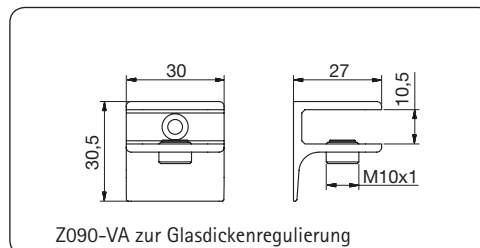

Tragfähigkeit:

| max. a | e1 | e2 | e3 | |
|--------|--------|--------|--------|------|
| | 100 mm | 200 mm | 300 mm | |
| 300 mm | 18 kg | 9,0 kg | 6,0 kg | 6 mm |

a = Abstand Glasplattenhalter, e = Ausladung

Art. Nr.: 3071

Glasplattenträger

1 Befestigungsbohrung Ø 4,5 mm
für Senkkopfschraube

Plattendicke: 6–10 mm

Material/Oberfläche VA = Edelstahl



VA1



VA2

Inklusive
Z090-VA



■ Glaslattenträger aus Edelstahl (VA)

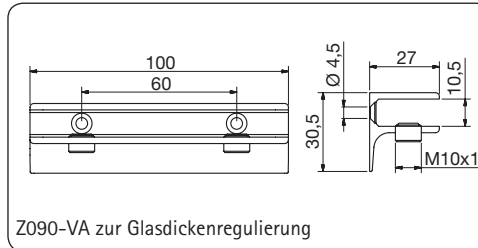

Tragfähigkeit:

| max. a | e1 | e2 | e3 | |
|--------|---------|---------|---------|------|
| | 100 mm | 200 mm | 300 mm | |
| 500 mm | 37,5 kg | 18,7 kg | 12,5 kg | 6 mm |

a = Abstand Glasplattenhalter, e = Ausladung

Art. Nr.: 3072

Glaslattenträger

2 Befestigungsbohrungen Ø 4,5 mm
für Senkkopfschrauben

Plattendicke: 6–10 mm

Material/Oberfläche VA = Edelstahl



VA1



VA2

Inklusive
Z090-VA

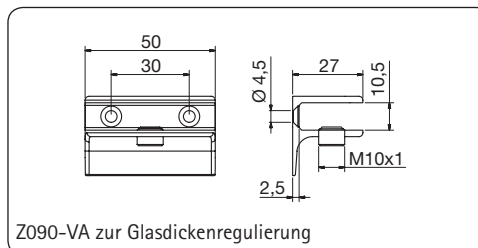
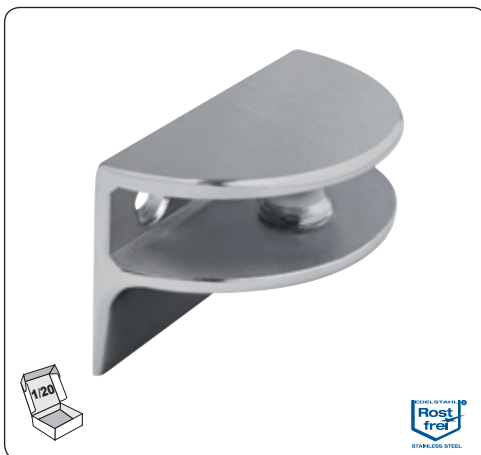

Tragfähigkeit:

| max. a | e1 | e2 | e3 | |
|--------|---------|--------|--------|------|
| | 100 mm | 200 mm | 300 mm | |
| 300 mm | 18,0 kg | 9,0 kg | 6,0 kg | 6 mm |

a = Abstand Glasplattenhalter, e = Ausladung

Art. Nr.: 3073

Glaslattenträger

2 Befestigungsbohrungen Ø 4,5 mm
für Senkkopfschrauben

Plattendicke: 6–10 mm

Material/Oberfläche VA = Edelstahl



VA1



VA2

Inklusive
Z090-VA

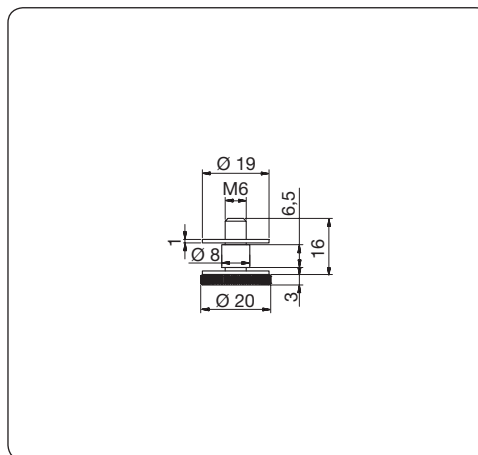

Art. Nr.: 2879

Rändelschraube M6x16

2 KU-Unterlegscheiben,
1 KU-Schlauchstück Ø 8 x Ø 6 x 6,5 mm

Material/Oberfläche VA = Edelstahl



VA0



VA1



VA2

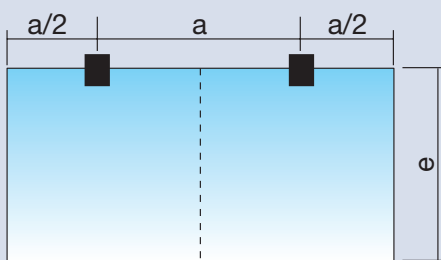

■ Tragfähigkeit Glasplattenträger

Die Maximallast kann als empfohlener Wert verstanden werden. Die Bruchlast liegt erheblich über dem empfohlenen Wert. Eine Erweiterung des Glasfeldes ist natürlich möglich, bitte beachten Sie dabei die maximale Abmessung max. a. Die angegebene Tragfähigkeit gilt bei gleichmäßiger Lastverteilung.



■ Tragfähigkeit Glasplattenträger

Ergebnisse beziehen sich auf die Verwendung von 4 Haltern.
Die Glasplattenträger sind gegenüberliegend zu verbauen.

Die angegebene Tragfähigkeit gilt bei gleichmäßiger Lastverteilung.





Glasplattenträger

- Glasplattenträger „Design-Kollektion“ aus Zink (ZN - ZAMAK®)



■ Glasplattenträger „Design-Kollektion“ aus Zink (ZN - ZAMAK®)

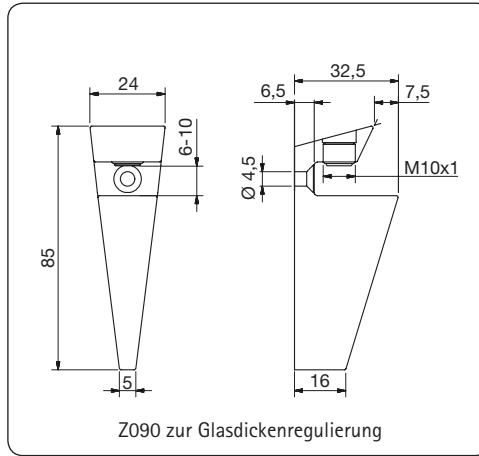

Art. Nr.: 10010

Glasplattenträger

1 Befestigungsbohrung \varnothing 4,5 mm
für Senkkopfschraube

Plattendicke:  6–10 mm

Material/Oberfläche ZN = Zink



RAL



ZN1



ZN5



ZN22

Inklusive
Z090

Tragfähigkeit:

| max. a | e1 | e2 | e3 |  |
|--------|--------|---------|--------|---|
| | 100 mm | 200 mm | 300 mm | |
| 300 mm | 7,5 kg | 3,75 kg | 2,5 kg | 6 mm |

a = Abstand Glasplattenhalter, e = Ausladung

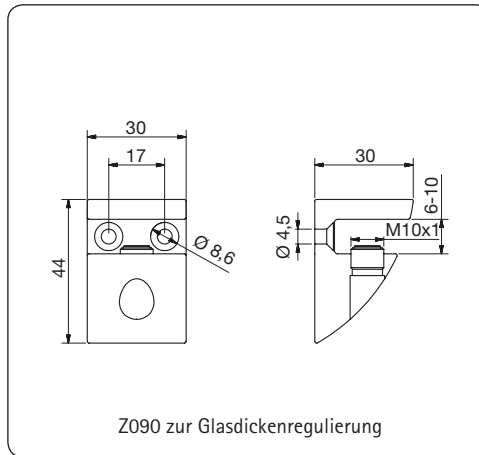

Art. Nr.: 10020

Glasplattenträger

2 Befestigungsbohrungen \varnothing 4,5 mm
für Senkkopfschrauben

Plattendicke:  6–10 mm

Material/Oberfläche ZN = Zink



RAL



ZN1



ZN5



ZN22

Inklusive
Z090

Tragfähigkeit:

| max. a | e1 | e2 | e3 |  |
|--------|---------|---------|---------|---|
| | 100 mm | 200 mm | 300 mm | |
| 500 mm | 37,5 kg | 18,7 kg | 12,5 kg | 6 mm |

a = Abstand Glasplattenhalter, e = Ausladung



■ Glasplattenträger „Design-Kollektion“ aus Zink (ZN - ZAMAK®)

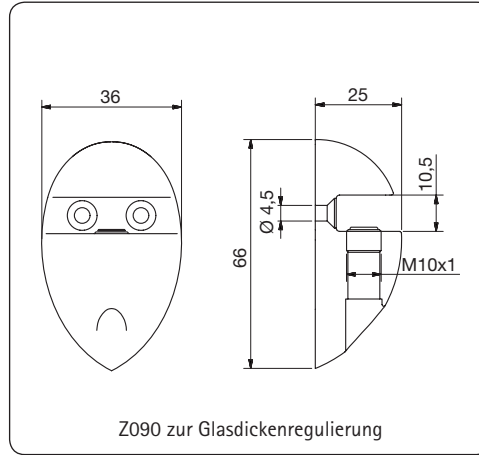

Tragfähigkeit:

| max. a | e1 | e2 | e3 | |
|--------|---------|--------|--------|------|
| | 100 mm | 200 mm | 300 mm | |
| 300 mm | 10,4 kg | 5,2 kg | 3,5 kg | 6 mm |

a = Abstand Glasplattenhalter, e = Ausladung

Art. Nr.: 10030

Glasplattenträger

2 Befestigungsbohrungen Ø 4,5 mm
für Senkkopfschrauben

Plattendicke: 6-10 mm

Material/Oberfläche ZN = Zink



RAL



ZN1



ZN5



ZN22

Inklusive
Z090

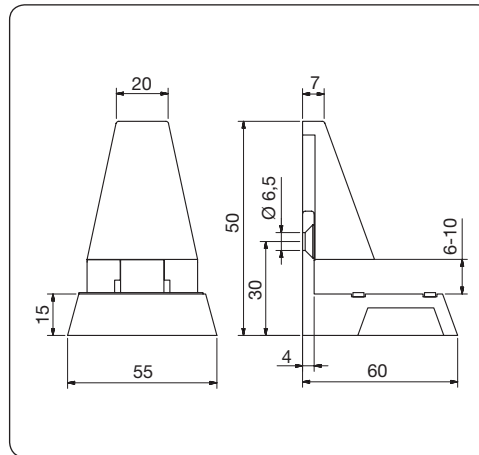

Tragfähigkeit:

| max. a | e1 | e2 | e3 | |
|--------|---------|--------|--------|------|
| | 100 mm | 200 mm | 300 mm | |
| 300 mm | 10,4 kg | 5,2 kg | 3,5 kg | 6 mm |

a = Abstand Glasplattenhalter, e = Ausladung

Art. Nr.: 10040

Glasplattenträger

1 Befestigungsbohrung Ø 6,5 mm
für Senkkopfschraube

Plattendicke: 8-12 mm

Material/Oberfläche ZN = Zink



RAL



ZN1



ZN5



ZN22



■ Glasplattenträger „Design-Kollektion“ aus Zink (ZN - ZAMAK®)

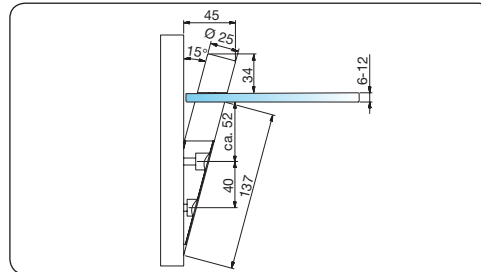

Tragfähigkeit:

| max. a | e1 | e2 | e3 | |
|--------|--------|---------|--------|------|
| | 100 mm | 200 mm | 300 mm | |
| 300 mm | 7,5 kg | 3,75 kg | 2,5 kg | 6 mm |

a = Abstand Glasplattenhalter, e = Ausladung

Art. Nr.: 10000

Glasplattenträger

2 Befestigungsbohrungen \varnothing 6 mm

Plattendicke: 6-12 mm

Material/Oberfläche ZN = Zink

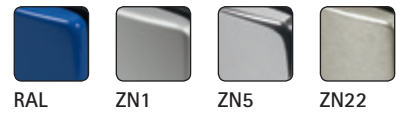

RAL

ZN1

ZN5

ZN22





■ Glasscheiben für Glasplattenträger 10000

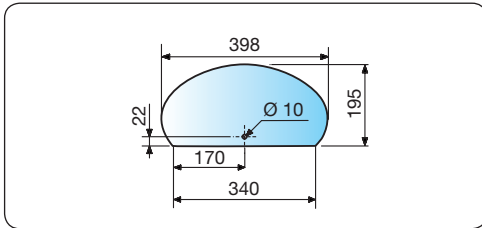

Art. Nr.: 1100001GLAS/1100011GLAS

| | |
|-------------------|-----------------------|
| 1100001GLAS | Sicherheitsglas (ESG) |
| Glas 398x195x6 mm | ungebohrt |

| | |
|-------------------|--------------------|
| 1100011GLAS | Glas nur für 10000 |
| Glas 398x195x6 mm | Ø 10 mm Bohrung |

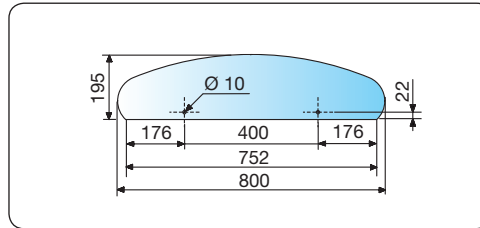

Art. Nr.: 1100030GLAS/1100033GLAS

| | |
|-------------------|-----------------------|
| 1100030GLAS | Sicherheitsglas (ESG) |
| Glas 800x195x6 mm | ungebohrt |

| | |
|-------------------|--------------------|
| 1100033GLAS | Glas nur für 10000 |
| Glas 800x195x6 mm | 2x Ø 10 mm Bohrung |

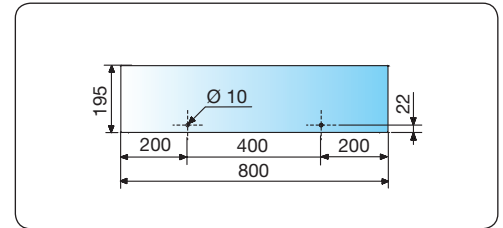

Art. Nr.: 1100050GLAS/1100055GLAS

| | |
|-------------------|-----------------------|
| 1100050GLAS | Sicherheitsglas (ESG) |
| Glas 800x195x6 mm | ungebohrt |

| | |
|-------------------|--------------------|
| 1100055GLAS | Glas nur für 10000 |
| Glas 800x195x6 mm | 2x Ø 10 mm Bohrung |



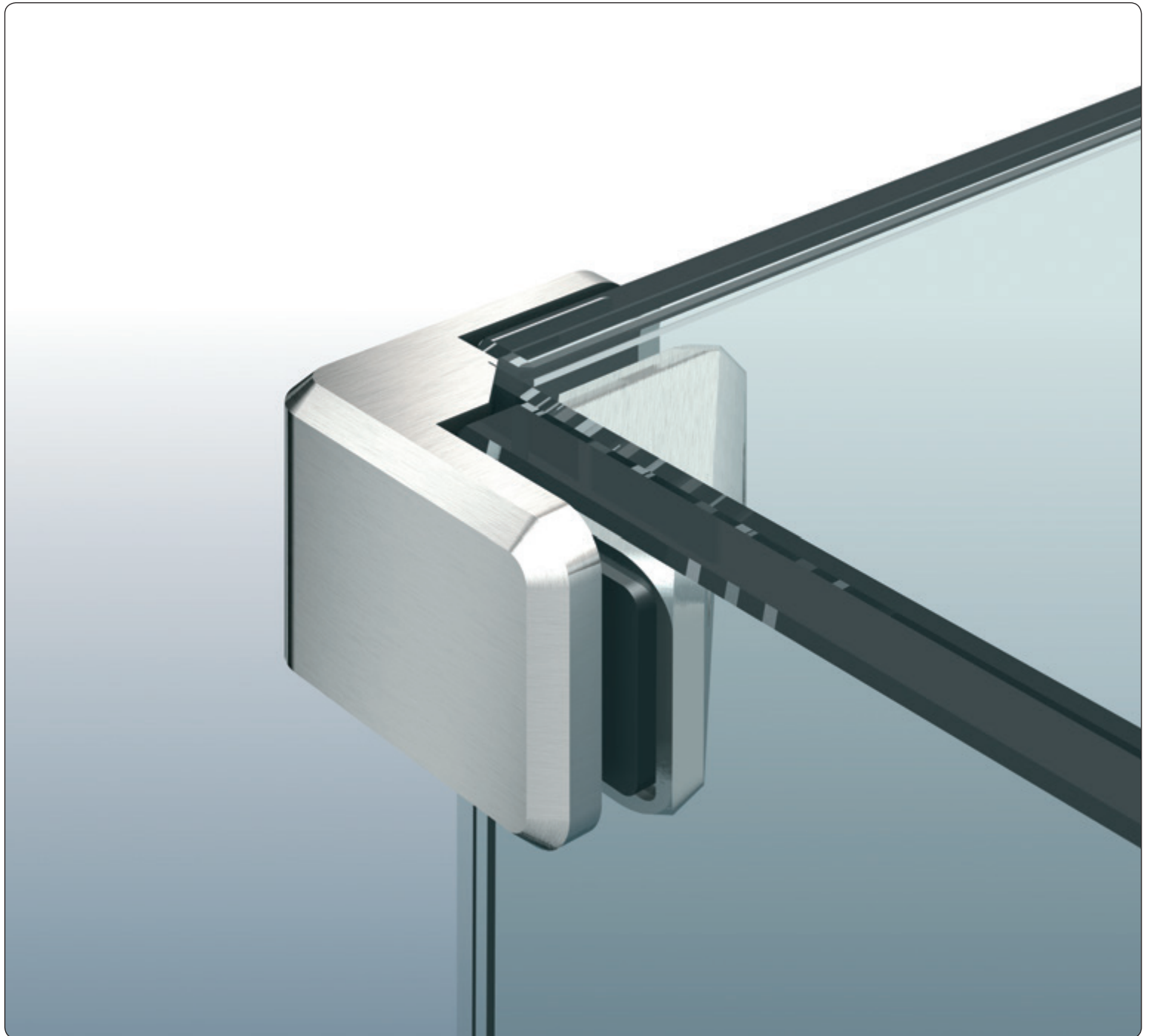

Glasplattenträger

- Verbinder aus Zink (ZN - ZAMAK®)





■ Verbinder aus Zink (ZN - ZAMAK®)

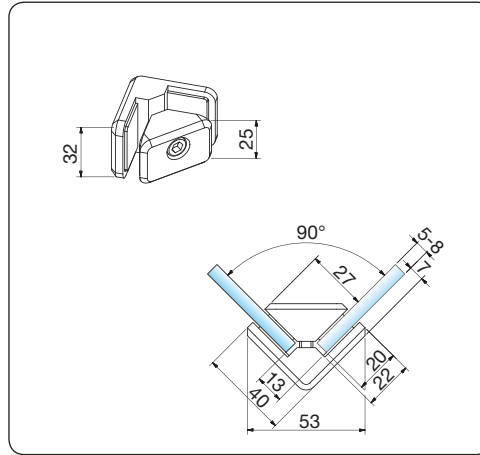

Art. Nr.: 4880

Winkelverbinder 90°

Plattendicke:  5-8 mm

Material/Oberfläche ZN = Zink

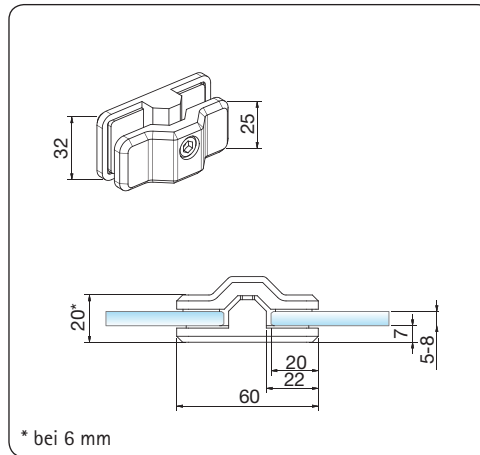
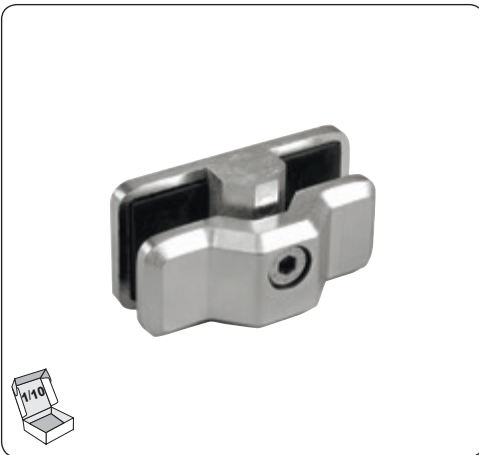

Art. Nr.: 4881

Mittelverbinder

Plattendicke:  5-8 mm

Material/Oberfläche ZN = Zink





■ Verbinder aus Zink (ZN - ZAMAK®)

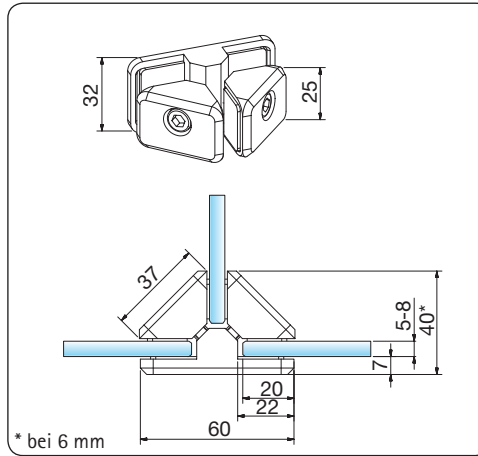

Art. Nr.: 4882

T-Verbinder

Plattendicke:  5-8 mm

Material/Oberfläche ZN = Zink

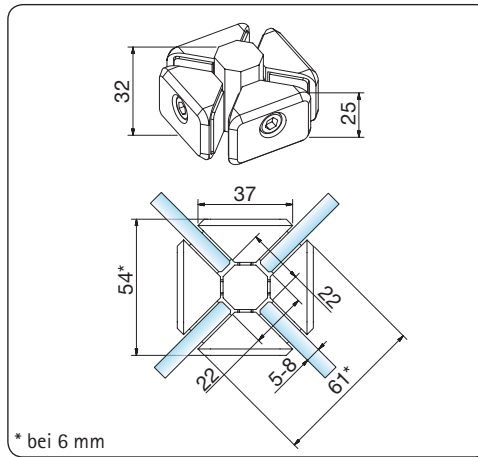
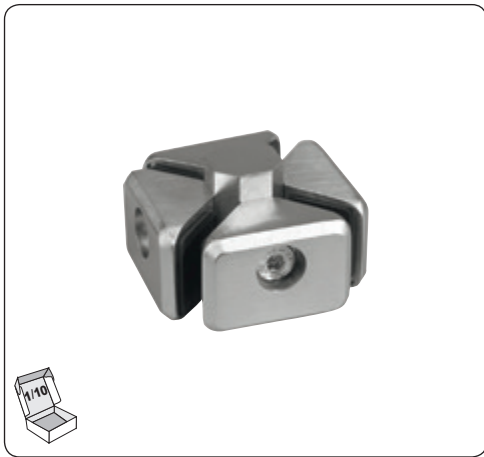

Art. Nr.: 4883

Kreuzverbinder

Plattendicke:  5-8 mm

Material/Oberfläche ZN = Zink





■ Verbinder aus Zink (ZN - ZAMAK®)

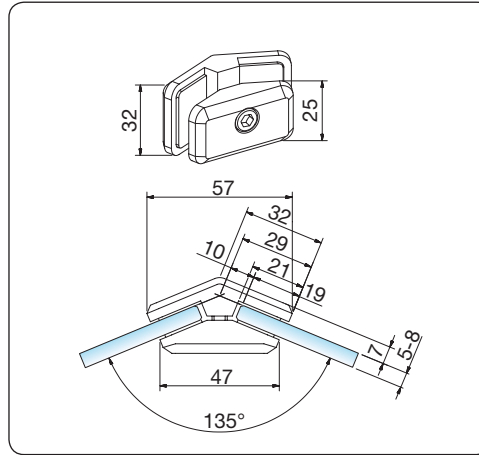

Art. Nr.: 4884

Gehrigsverbinder 135°

Plattendicke:  5-8 mm

Material/Oberfläche ZN = Zink

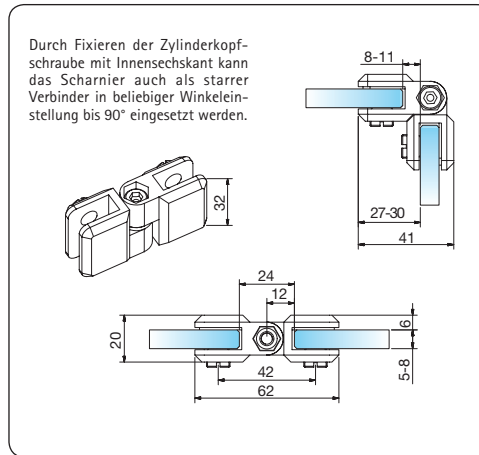

Art. Nr.: 4885

Scharnier und variabler Verbinder

Plattendicke:  5-8 mm

Öffnungswinkel: 90°-270°

Material/Oberfläche ZN = Zink

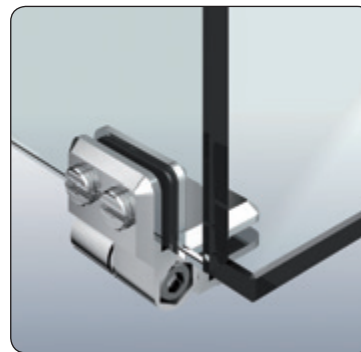
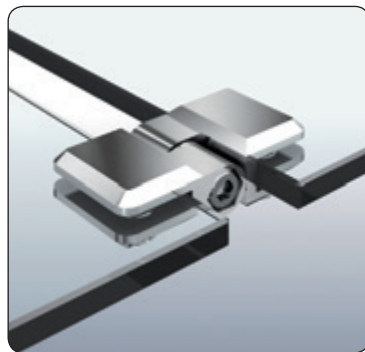
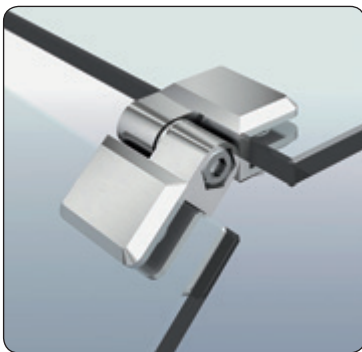



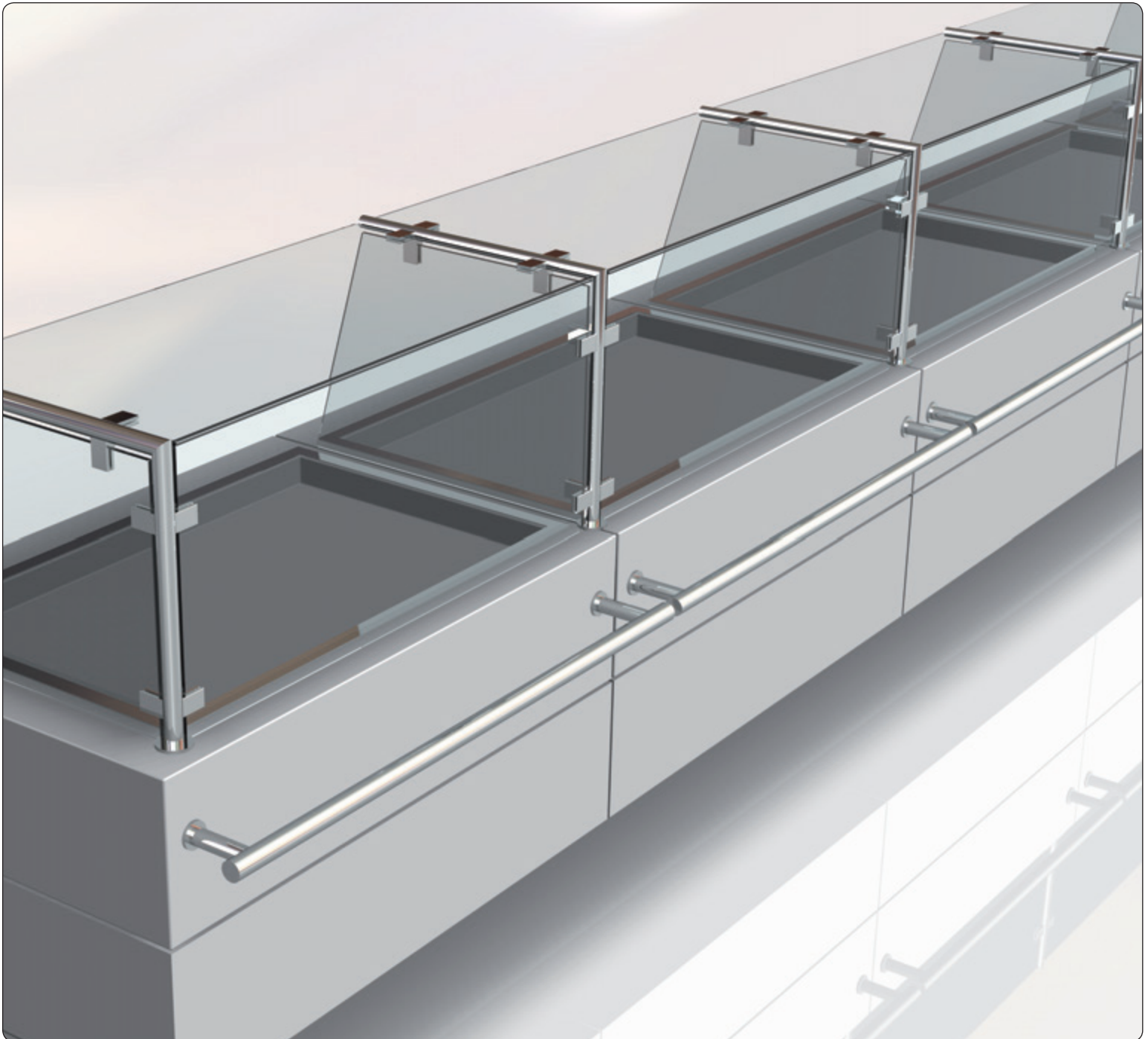

- Klemmen aus Zink (ZN - ZAMAK®)





■ Klemmen aus Zink (ZN - ZAMAK®)

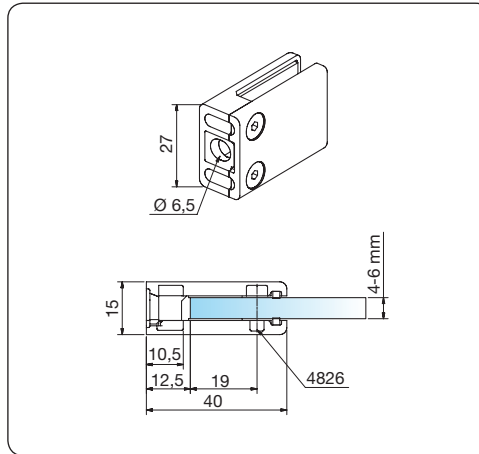

Art. Nr.: 3000, 3001

Klemmbefestigung

1 Befestigungsbohrung Ø 6,5 mm

Plattendicke Art. Nr. 3000: 4 mm

Plattendicke Art. Nr. 3001: 6 mm

Material/Oberfläche ZN = Zink

| | | | |
|-----|-----|------|--------------------------|
| | | | Zubehör 4826VA |
| ZN0 | ZN5 | ZN22 | |

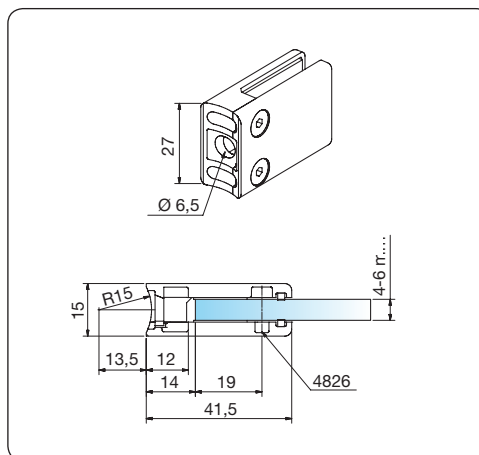

Art. Nr.: 3010, 3011

Klemmbefestigung für Rohranschluss Ø 30 mm

1 Befestigungsbohrung Ø 6,5 mm

Plattendicke Art. Nr. 3010: 4 mm

Plattendicke Art. Nr. 3011: 6 mm

Material/Oberfläche ZN = Zink

| | | | |
|-----|-----|------|--------------------------|
| | | | Zubehör 4826VA |
| ZN0 | ZN5 | ZN22 | |



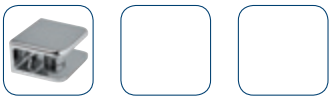

■ Klemmen aus Zink (ZN - ZAMAK®)

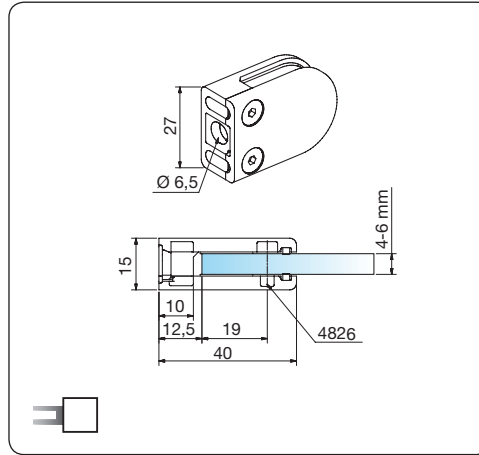

Art. Nr.: 3020, 3021

Klemmbefestigung

1 Befestigungsbohrung \varnothing 6,5 mm

Plattendicke Art. Nr. 3020:  4 mm

Plattendicke Art. Nr. 3021:  6 mm

Material/Oberfläche ZN = Zink



ZN0



ZN5



ZN22

Zubehör
4826VA

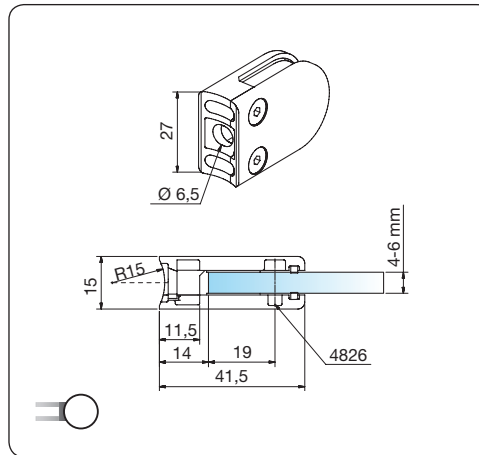

Art. Nr.: 3030, 3031

Klemmbefestigung für Rohranschluss \varnothing 30 mm

1 Befestigungsbohrung \varnothing 6,5 mm

Plattendicke Art. Nr. 3030:  4 mm

Plattendicke Art. Nr. 3031:  6 mm

Material/Oberfläche ZN = Zink



ZN0



ZN5



ZN22

Zubehör
4826VA

■ Zubehör

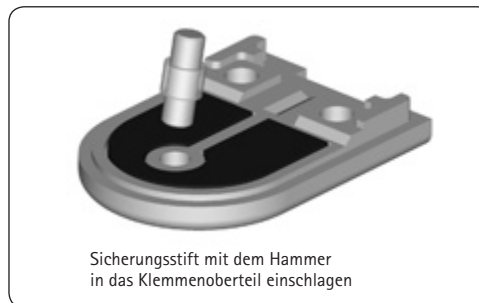

Art. Nr.: 4826VA

Sicherungsstift \varnothing 4 x 12 mm

Material/Oberfläche VA = Edelstahl

Plattenbohrung
 \varnothing 10 mm

Auf die Pflege kommt es an!



■ Pflegehinweise Edelstahl:

Die Pflege von Edelstahl im Innenbereich ist einfach und mit regelmäßiger Pflege bleibt das Material schön und haltbar.

Klares Wasser und ein sauberes Tuch genügen in der Regel für saubere Ergebnisse. Natürlich können auch spezielle phosphorsäurehaltige Edelstahl-Reiniger eingesetzt werden.

Sie entfernen Fremdeisenpartikel. Behandelt werden sollte immer die komplette Oberfläche eines Bauteils, um ein gleichmäßiges, fleckenfreies Ergebnis zu erzielen.

Wichtig: Für die Reinigung von Edelstahl sollten generell eisenfreie Reinigungsmaterialien benutzt werden, da sonst die Edelstahloberfläche beschädigt wird.



■ Pflegehinweise Zink:

Bei Produkten aus Zinkdruckguss spielt das Oberflächenfinish eine entscheidende Rolle. Pulverbeschichtete Produkte zeichnen sich durch eine sehr gute Witterungsbeständigkeit aus. Sie sind also neben Innenanwendungen besonders für die Verwendung im Außenbereich zu empfehlen.

Bei Galvanisch veredelten Produkten ist zu beachten, dass z. B. Oberflächen wie glanzverchromt hervorragend für Innen – und Außenanwendungen geeignet sind, während Edelstahlfinish oder Edelstahleffekt mit Klarlack versiegelt werden,

um ebenfalls für den Außenbereich geeignet zu sein. Bei allen Produkten sollte eine regelmäßige Pflege stattfinden (ca. alle 2 Monate je nach Bedarf). Bestens geeignet ist lauwarmes Wasser und ein weiches Tuch. Ungeeignet hingegen sind chemische Reinigungsmittel.



■ Pflegehinweise Aluminium:

Leichte Verunreinigungen sollten Sie mit einem Schwamm, lauwarmen Wasser und neutralen Reinigungsmittel entfernen. Vermeiden Sie in jedem Fall eine trockene Reinigung, da sonst Kratzer auf der Oberfläche entstehen könnten. Mit einem Fensterleder lassen sich anschließend noch verbleibende Wischspuren oder sichtbare Wassertropfenverläufe entfernen. Aluminium hat zwar eine sehr glatte Oberfläche, aber Fett und Öl haften dennoch gut darauf. Aluminiumteile sollten also immer sehr gründlich entfettet werden.

Wir empfehlen Ihnen Handschuhe zu tragen um keine fettigen Fingerabdrücke nach der Reinigung zu hinterlassen. Die Reinigung sollte mit Lösungsmitteln, z.B. Verdünnung, speziellen Reinigern oder Entfettern vorgenommen werden. Es sollten niemals alkalische oder saure Reiniger verwendet werden. Stumpf gewordene und bereits oxidierte Oberflächen (erkennbar an weißen Korrosionsprodukten) können Sie mit einem Schleifvlies reinigen, ansonsten empfehlen wir Ihnen spezielle Reinigungsmittel zu verwenden.



■ Pflegehinweise Kunststoff:

Die Oberfläche dieses Materials ist so glatt, dass Verunreinigungen praktisch keinen Halt finden. Für das Reinigen von Kunststoff sollte stets Wasser mit etwas Haushaltsspülmittel benutzt werden. Die Oberflächen niemals trocken abwischen! Bei hartnäckigeren Verunreinigungen ist ein mildes Reinigungsmittel oder ein antistatischer Kunststoffreiniger zu verwenden. Gute Reinigungsergebnisse ohne Schlieren lassen sich auch mit einem feuchten Wischtuch erzielen. Fetthaltige Verunreinigungen lassen sich mit sogenanntem Wasch- bzw. Leichtbenzin entfernen.



■ Pflegehinweise Messing:

Mit einem trockenen Mikrofasertuch können Sie leichte Verschmutzungen und Fingerabdrücke sanft entfernen und danach gut Trockenreiben. Bei hartnäckiger Verschmutzung sollte der Einsatz von Spülmittel mit einem weichen Tuch ausreichen.

Bitte keine Reiniger verwenden, die Säure, Alkohol, Benzin, Scheuerpartikel oder sonstige aggressive Bestandteile enthalten.





■ Allgemeine Geschäftsbedingungen

AGB

Bestellungen von Produkten aus diesem Katalog führen wir ausschließlich auf der Grundlage und unter Geltung unserer „Allgemeinen Verkaufs- und Lieferbedingungen“ durch. Hiervon abweichende Bedingungen, z. B. allgemeine Einkaufsbedingungen, werden von uns nicht akzeptiert und wir behalten uns ausdrücklich vor, Bestellungen, in denen auf derartige abweichende Bedingungen hingewiesen wird, nicht auszuführen. Unsere „Allgemeinen Verkaufs- und Lieferbedingungen“ können Sie in unseren Geschäftsräumen sowie im Internet auf unserer Homepage www.pauli.de einsehen. Zudem übersenden wir Ihnen gerne ein Exemplar auf Anfrage per Post oder Telefax.

Erfüllungsort für sämtliche vertraglichen Verpflichtungen sowie der Gerichtsstand für alle gerichtlichen Auseinandersetzungen sind im kaufmännischen Rechtsverkehr ausschließlich der Sitz unseres Unternehmens in Morsbach.

Schutzrechte

Für zahlreiche Artikel in diesem Katalog sind Patente, Gebrauchs- oder Geschmacksmuster angemeldet oder eingetragen.

Der vorliegende Katalog ist ausschließlich für den Empfänger bestimmt. Er darf nicht weiterverliehen oder Wettbewerbsunternehmen überlassen werden.

Der Herausgeber behält sich das Rückforderungsrecht vor.

Copyright

Nachdrucke – auch auszugsweise – bedürfen unserer ausdrücklichen, schriftlichen Genehmigung.

Haftungsausschluss

Der Herausgeber haftet nicht für Druckfehler und Irrtümer in diesem Katalog. Druckbedingte Farbabweichungen sind möglich. Im Rahmen der Weiterentwicklung unseres Programms behalten wir uns technische Änderungen sowie den Wegfall einzelner Artikel ohne besondere Ankündigung vor.



Werk I: Eisenstraße 2, D-51545 Waldbröl, Telefon +49 (0) 22 91-92 06-0, Telefax +49 (0) 22 91-92 06-681
 Werk II: Industriestraße 20, D-51597 Morsbach, Telefon +49 (0) 22 94-98 03-0, Telefax +49 (0) 22 94-98 03-881
 Internet: www.pauli.de, e-Mail: pauli@pauli.de

ClimatePartner[®]
wir drucken klimaneutral

Klimaneutral drucken mit ClimatePartner bedeutet angewandter Klimaschutz und zuverlässiger Emissionsausgleich auf höchstem Niveau.

Pauli + Sohn GmbH

Alle Bilder, technischen Zeichnungen und deren Beschreibungen sind urheberrechtlich geschütztes Eigentum der Pauli + Sohn GmbH. Technische Maßangaben innerhalb des Kataloges sind unverbindlich. Konstruktionsänderungen sind vorbehalten. Bitte beachten Sie unsere Schutzrechte. Für Druckfehler und Irrtümer, die bei der Herstellung unterlaufen sind, ist jede Haftung ausgeschlossen.

www.pauli.de

Stand: Mai 2014

